

# CATALOGO DE REPUESTOS

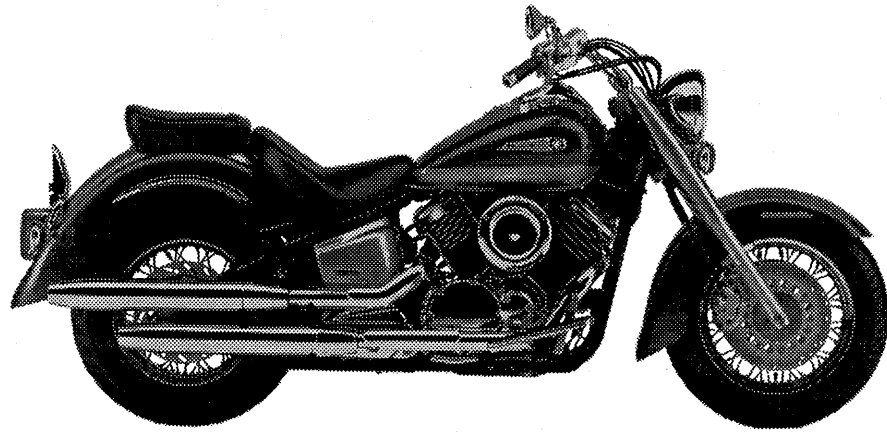
## XVS1100A (5KSB) ESPAÑA

115KS-352S1

**YAMAHA**  
**GENUINE**  
Parts & Accessories  
2007/06/27

NEWS No.	DATE	COMMENT
PE0-MC-040092	Aug., 17, 2004	FIG.37: FLASHER LIGHT LIST&ILLUSTRATION REVISION
PE0-MC-050086	Sep., 19, 2005	FIG.19: FRAME & FIG.27: SEAT LIST&ILLUSTRATION MODIFICATION
PE0-MC-060052	May., 22, 2006	FIG.5: CAMSHAFT&CHAIN ILLUSTRATION CORRECTIONS
PE0-MC-070028	Apr., 09, 2007	FIG.26: FUEL TANK LIST&ILLUSTRATION CORRECTION
PE0-MC-070041	Jun., 13, 2007	FIG.29: FRONT BRAKE CALIPER LIST&ILLUSTRATION CORRECTION

A2



A3

# PROLOGO

Este Catálogo de Repuestos corresponde a las piezas para el(los) modelo(s) del recuadro siguiente. Al formular el pedido de repuestos, se ruega citar este Catálogo de Repuestos y especificar correctamente los números de parte y los nombres de parte.

XVS1100A(5KSB)

1. Las modificaciones y agregados que se hayan realizado después de la edición de este Catálogo de Repuestos, serán anunciados en las Informaciones de Recambios Yamaha.
2. Abreviaciones  
En este Catálogo de Repuestos se emplean las siguientes abreviaciones.  
"UR" Usar el número de partes especificado  
"UN" Usar la cantidad necesaria  
"AP" Piezas sustitutivas  
"LM" Fabricación local (Partes necesarias que se pedirán localmente)  
"F#" No. de bastidor aplicable
3. Las piezas suministradas como conjunto se describen con un punto (.) que precede al nombre de la pieza como se indica a continuación.

**EJEMPLO**

CONJUNTO CARBURADOR

.INYECTOR, piloto

.BOQUILLA, principal

4. Cantidad de componentes de un conjunto  
La numeración que aparece a la derecha de cada descripción, indica la cantidad de piezas por cada unidad de conjunto.

**EJEMPLO**

PIEZAS NO.	DESCRIPCION	CANT.	OBSERVACION
2F5-83310-60	ENSAMBLAJE DE LA LUZ	2	
115-83311-60	.BOMBILLA (6V-1 8W)	1	
1M1-83309-60	.REFLECTOR	1	

5. Los colores de los componentes se indican como sigue en la columna de "OBSERVACIONES".

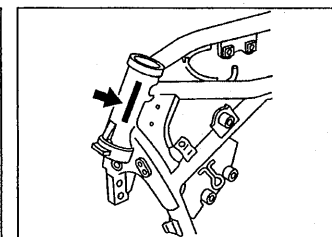
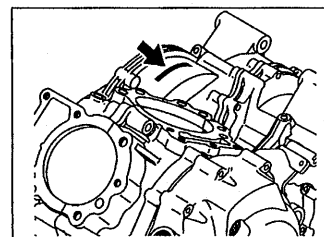
**EJEMPLO**

PIEZAS NO.	DESCRIPCION	CANT.	OBSERVACION
2N4-24110-00-X5	.COMP. DEL TANQUE	2	MXR
3J1-24240-10	.GRAFICO, DEL TANQUE	1	para MXR

6. Números de Serie

No. de Serie del motor.

No. de Serie del bastidor



7. Debe tenerse en cuenta que las ilustraciones sirven como guía para la búsqueda de las referencias y no deben usarse para el montaje. Durante el montaje, se recomienda usar el manual de Taller correspondiente.
8. EL asterisco (\*) antes del número de referencia indica los elementos modificados después de la primera edición.



# CONTENIDO

## MOTOR

CULATA DE CILINDRO .....	B2
CILINDRO .....	B4
CIGUENAL. PISTON .....	B5
VALVULA .....	B6
ARBOL DE LEV. CADENA .....	B7
BOMBA DE ACEITE .....	B8
FILTRO ACEITE .....	B9
ADMISION .....	B10
CARBURADOR .....	B12
DESCARGA .....	B15
CARTER .....	C3
CUBIERTA DE CARTER 1 .....	C4
ARRANQUE .....	C6
EMBRAGUE .....	C7
TRANSMISION .....	C9
ENGR. MEDIO DE TRAC. ....	C10
LEVA DE CAMBIO. HORQ .....	C12
EJE DE CAMBIO. PEDAL .....	C13

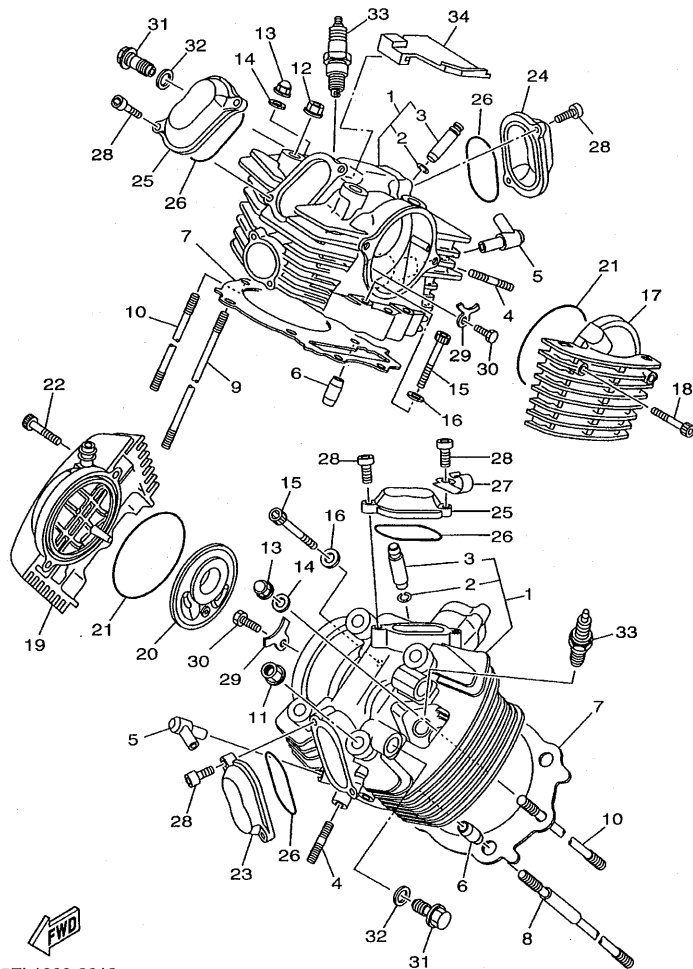
## SHASIS

CUADRO .....	C14
GUARDABARRO .....	D2
CUBIERTA LATERAL .....	D4
BRAZO TRASERO. SUSPENSION .....	D7
EJE DE TRACCION .....	D9
DIRECCION .....	D11
HORQUILLA DELANTERA .....	D12
DEPOSITO DE COMBUSTIBLE .....	D14
ASIENTO .....	E2
RUEDA DELANTERA .....	E3

CALIBRE FRENO DELANTERA .....	E4
RUEDA TRASERA .....	E5
CALIBRE FRENO TRASERA .....	E6
MANUBRIO. CABLE .....	E7
CILINDRO MAESTRO DELANTERO .....	E8
SOPORTE. APOYAPIE .....	E9
CILINDRO MAESTRO TRASERO .....	E11
GENERADOR .....	E12
LUZ DE DESTELLADOR .....	E13
MEDIDOR .....	E15
FARO DELANTERO .....	F2
LUZ DE COLA .....	F3
INTERRUPTOR DE MANIJA. PALANCA .....	F4
EQUIPO ELECTRICO 1 .....	F5
EQUIPO ELECTRICO 2 .....	F6

## INDICE

NUMERICAL INDEX .....	M1
-----------------------	----



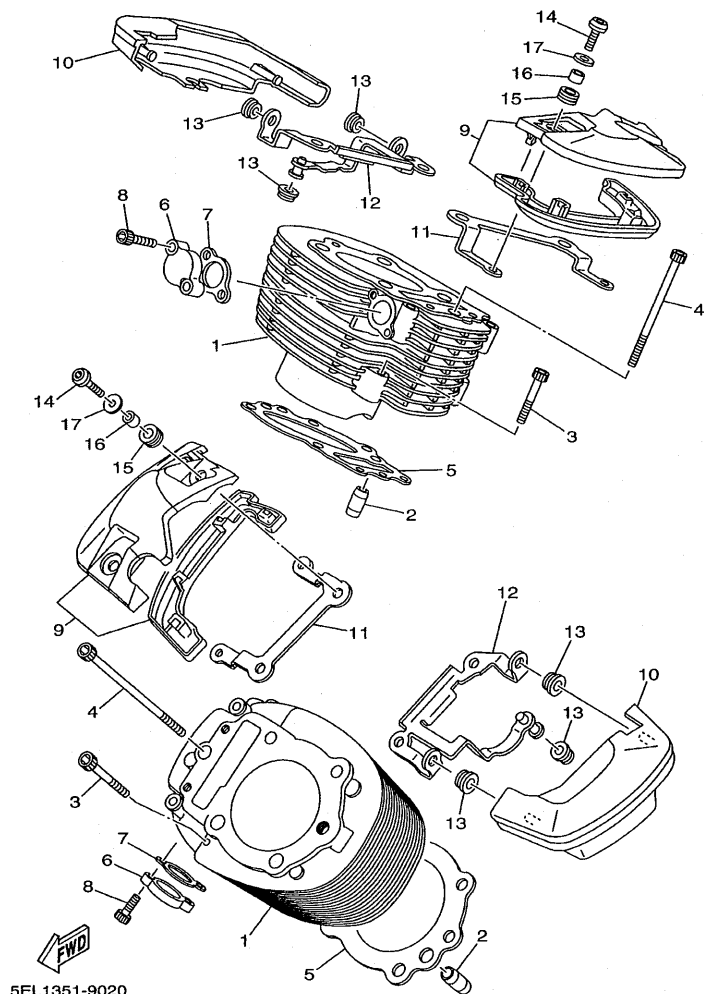
5EL1300-9010

FIG. 1 CULATA DE CILINDRO

REF. NO.	CODIGO NO.	DESCRIPCION	5KSB				OBSERVACION
1	5KS-11102-00	CULATA DE CILINDRO COMPLETA	2				
2	93440-14086	.BOLA	2				
3	4X7-11133-10	.GUIA VALV.DE ADM.	2				
4	95617-08625	PERNO DE PUNTAL	4				
5	5EL-14875-00	TUBO 5	2				
6	91817-30011	PASADOR DE CLAVIJA	4				
7	5EL-11181-00	JUNTA, DE CULATA 1	2				
8	4X7-11363-01	PERNO RETEN DE CILINDRO 3	4				
9	90116-12469	ESPARRAGO	4				
10	90116-10344	ESPARRAGO	2				
11	90179-12326	TUERCA	4				
12	90179-12325	TUERCA	4				
13	90176-10075	TUERCA CORONA	2				
14	90201-101A4	ARANDELA PLANA	2				
15	91314-08050	PERNO	4				
16	92907-08600	ARANDELA	4				
17	5KS-1111H-00	CUBIERTA LATERALE DE CULATA 4	1				
18	91314-06035	PERNO	2				
19	5KS-11185-00	CUBIERTA CULATA CIL.LAT.1	1				
20	42X-11165-00	PLACA RESPIRADERO	1				
21	93210-92448	ANILLO O	2				
22	91314-06035	PERNO	2				
23	42H-11186-01	CUBIERTA CULATA CIL.LAT.2	1				
24	5EL-11187-00	CUBIERTA CULATA CIL.LAT.3	1				
25	4X7-11187-01	CUBIERTA CULATA CIL.LAT.3	2				
26	93210-62446	ANILLO O	4				
27	90465-10264	BRIDA	1				



FIG. 2 CILINDRO

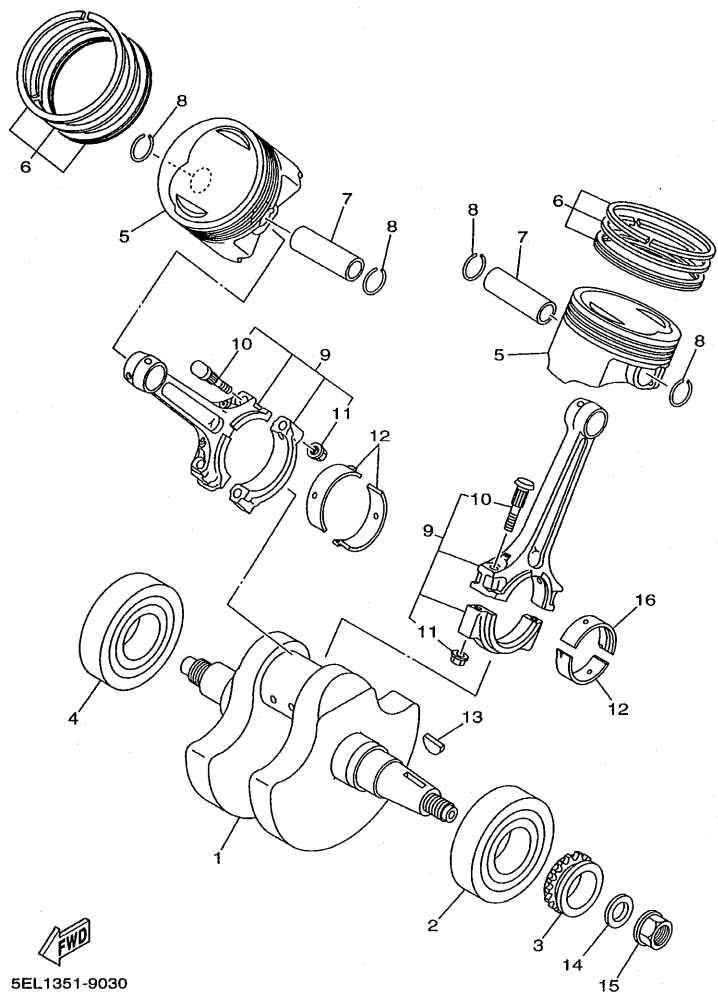


5EL1351-9020

REF. NO.	CODIGO NO.	DESCRIPCION	5KSB				OBSERVACION
1	5KS-11311-00	CILINDRO 1	2				
2	90387-087A5	CASQUILLO CON VALONA	4				
3	91314-06040	PERNO	4				
4	91314-06100	PERNO	2				
5	5EL-11351-00	JUNTA, DE CILINDRO	2				
6	5KS-12215-00	TAPA CAJA DE TENSOR	2				
7	4FM-12213-00	EMPAQUE DE CAJA TENSOR	2				
8	91314-06025	PERNO	4				
9	5EL-11190-00	TAPA CULATA DE CILINDRO 1	2				
10	5EL-11186-00	CUBIERTA CULATA CIL.LAT.2	2				
11	5EL-11152-00	SOPORTE DE CULATA DE CINDRO CU	2				
12	5EL-11142-00	SOPORTE DE CULATA DE CINDRO CU	2				
13	90480-10627	TAPON	6				
14	90149-06298	TORNILLO DE REGLAJE	4				
15	90480-13018	TAPON	4				
16	90387-066M3	CASQUILLO CON VALONA	4				
17	90201-06057	ARANDELA PLANA	4				



FIG. 3 CIGUENAL. PISTON

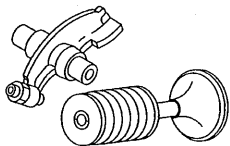
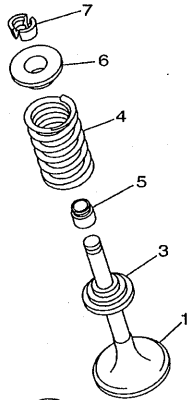
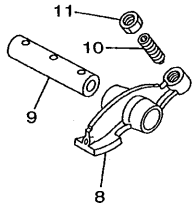
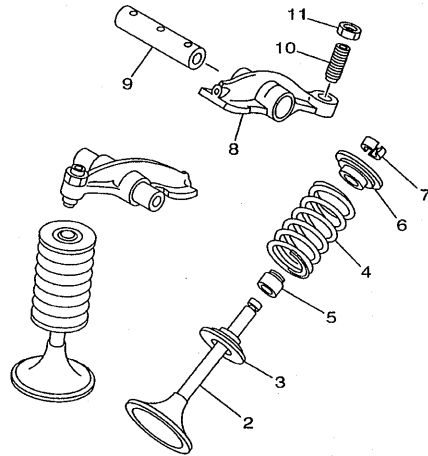


5EL1351-9030

REF. NO.	CODIGO NO.	DESCRIPCION	5K5B		OBSERVACION
1	5EL-11411-10	CIGUENAL	1		
2	93306-30808	COJINETE	1		
3	4X7-13354-00	CATALINA	1		
4	93306-30808	COJINETE	1		
5	5EL-11631-00	PISTON (STD)	2		
6	1TA-11610-00	JUEGO DE AROS (NORMA)	2		
7	4WM-11633-00	PASADOR, PISTON	2		
8	93450-24028	BOLA	4		
9	5EL-11650-10	BIELA COMPLETA	2		
10	4X7-11654-01	TORNILLO DE BIELA	2		
11	90179-09379	TUERCA	2		
12	4X7-11656-00	COJINETE PLANO	3		UR AZUL
	4X7-11656-10	COJINETE PLANO	3		UR NEGRO
	4X7-11656-20	COJINETE PLANO	3		UR CASTANO
	4X7-11656-30	COJINETE PLANO	3		UR VERDE
	4X7-11656-40	COJINETE PLANO	3		UR AMARILLO
13	90280-05048	CUNA WOODRUFF	1		
14	90201-165H4	ARANDELA PLANA	1		
15	90179-16448	TUERCA	1		
16	5G5-11656-00	COJINETE PLANO	1		UR NEGRO
	5G5-11656-10	COJINETE PLANO	1		UR CASTANO
	5G5-11656-20	COJINETE PLANO	1		UR VERDE

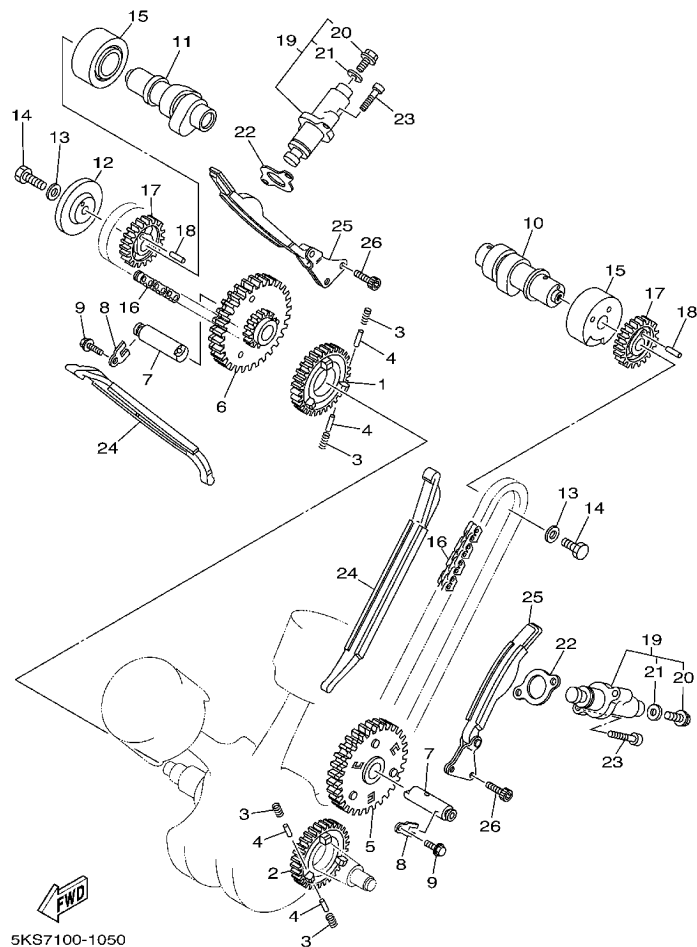
FIG. 4 VALVULA

REF. NO.	CODIGO NO.	DESCRIPCION	9K/5B				OBSERVACION
1	2J2-12111-01	VALVULA DE ADMISION	2				
2	5A8-12121-00	VALVULA DE ESCAPE	2				
3	4X7-12116-00	ASIENTO RESORTE DE VALVULA	4				
4	90501-44455	RESORTE DE COMPRESION	4				
5	341-12119-02	SELLO DE ACEITE VALVULA	4				
6	4X7-12117-00	RETEN RESORTE DE VALVULA	4				
7	4X7-12118-00	SEGURO DE VALVULA	8				
8	42X-12151-00	BRAZO DE BALANCIN DE VALVULA	4				
9	4X7-12156-01	EJE DE BALANCIN	4				
10	4X7-12159-00	TORNILLO DE AJUSTE DE VALVULA	4				
11	90170-08173	TUERCA	4				



5EL1351-9040

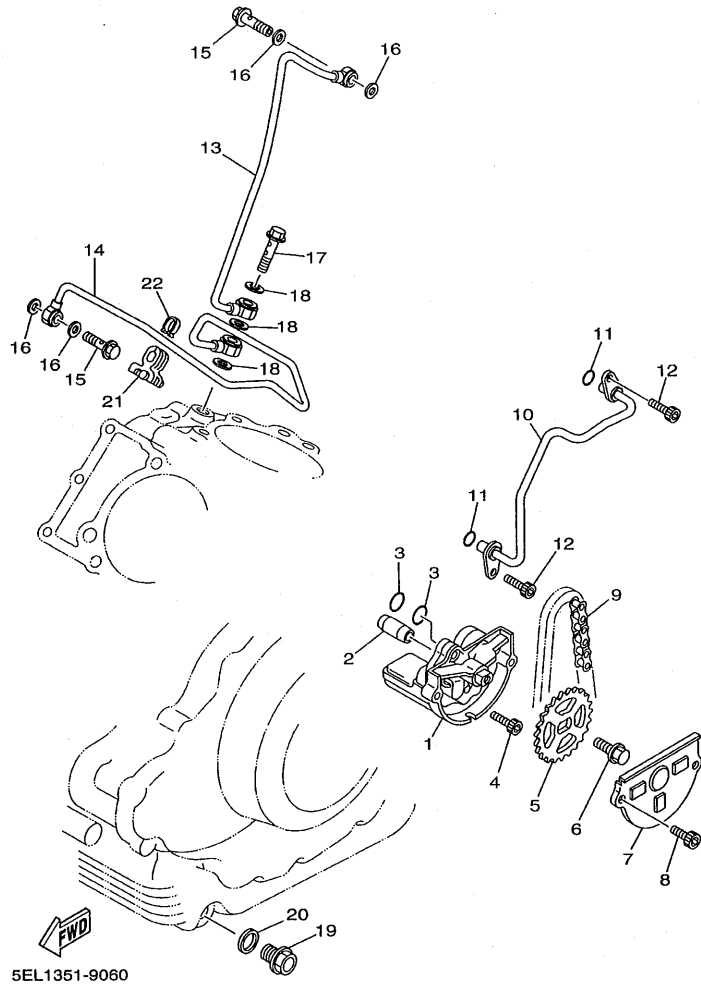
FIG. 5 ARBOL DE LEV. CADENA



5KS7100-1050

REF. NO.	CODIGO NO.	DESCRIPCION	5KSB				OBSERVACION
1	4X7-11536-00	ENGRANAJE TRACCION (35T)	1				
2	4X7-11534-00	ENGRANAJE TRACCION DE INTERRUP	1				
3	90501-21133	RESORTE DE COMPRESION	12				
4	93605-10090	PASADOR DE CLAVIJA	12				
5	5EL-11540-01	CATALINA DE CADENA COMPLETO	1				
6	5EL-11550-01	CATALINA COMP DE CADENA	1				
7	5EL-12247-00	EJE TENSOR	2				
8	90209-06205	ARANDELA DE SEPARACION	2				
9	90105-06154	TORNILLO CON ARANDELA	2				
10	5EL-12171-00	ARBOL DE LEVAS 1	1				
11	5EL-12181-00	ARBOL DE LEVAS 2	1				
12	42X-11145-00	PLACA RESPIRADERO 2	1				
13	90201-10591	ARANDELA PLANA	2				
14	90101-10303	TORNILLO	2				
15	90380-25125	CASQUILLO SOLIDO	2				
16	94591-49098	CADENA	2				
17	5EL-12176-00	CATALINA DE CADENA	2				
18	93604-12037	PASADOR DE CLAVIJA	2				
19	5EL-12210-01	TENSOR CADENA DE LEVA	2				
20	5EL-12228-00	PERNO	1				
21	5EL-12214-00	EMPAQUE	1				
22	4FM-12213-00	EMPAQUE DE CAJA TENSOR	2				
23	91314-06025	PERNO	4				
24	5EL-12231-00	TOPE DE GUIA 1	2				
25	5EL-12241-00	TOPE DE GUIA 2	2				
26	91314-06016	PERNO	4				

FIG. 6 BOMBA DE ACEITE



5EL1351-9060

REF. NO.	CODIGO NO.	DESCRIPCION	EX/SB				OBSERVACION
1	5EL-13300-01	BOMBA DE ACEITE COMPLETA	1				
2	99530-08016	PASADOR, DE ESPIGA	1				
3	93210-07135	ANILLO O	2				
4	91317-06040	PERNO	3				
5	4X7-13355-00	CATALINA IMPULSADA (35T)	1				
6	90105-06154	TORNILLO CON ARANDELA	1				
7	10L-13327-00	CUBIERTA ENGRANAJE DE BOMBA	1				
8	91317-06010	PERNO	2				
9	94580-25066	CADENA	1				
10	4X7-13171-00	TUBO CONDUCTOR 2	1				
11	93210-07135	ANILLO O	2				
12	91317-06010	PERNO	2				
13	5EL-13405-00	TUBO DE ACEITE COMPL. 1	1				
14	5EL-13406-00	TUBO DE ACEITE COMPL. 2	1				
15	90401-16067	PERNO DE UNION	2				
16	90430-17168	JUNTA	4				
17	90401-10102	PERNO DE UNION	1				
18	90430-15169	JUNTA	3				
19	90340-14132	TORNILLO, DE DRENAJE	1				
20	214-11198-01	EMPAQUE	1				
21	5EL-15485-00	GRAMPA	1				
22	90468-05113	PRESILLA	1				

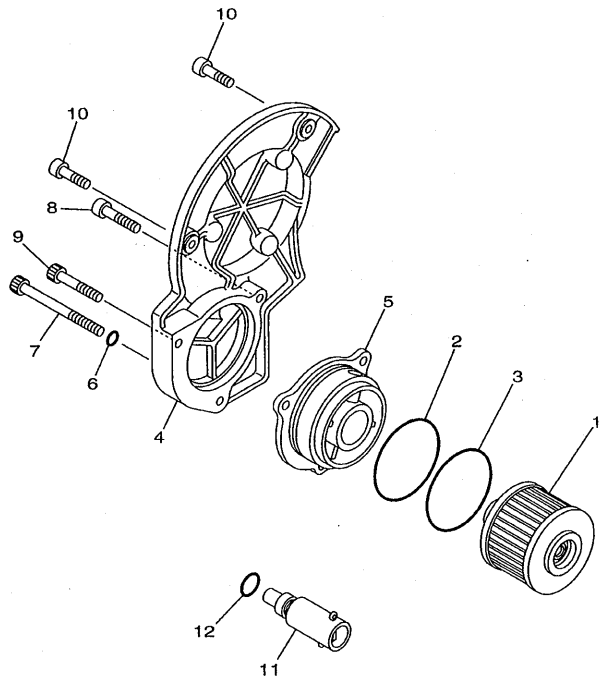


FIG. 7 FILTRO ACEITE

REF. NO.	CODIGO NO.	DESCRIPCION	5K9B				OBSERVACION
1	4X7-13440-01	ELEMENTO FILTRO DE ACEITE	1				
2	93210-56459	ANILLO O	1				
3	93210-54452	ANILLO O	1				
4	5EL-13447-00	TAPA DEL ELEMENTO	1				
5	5EL-13448-00	TAPA	1				
6	93210-07135	ANILLO O	1				
7	90109-06667	PERNO	1				
8	91314-06040	PERNO	1				
9	91314-06050	PERNO	1				
10	91314-06020	PERNO	2				
11	4G0-13490-01	VALVELA DE DESCOMPRESION	1				
12	93210-10096	ANILLO O	1				



5EL1351-9070

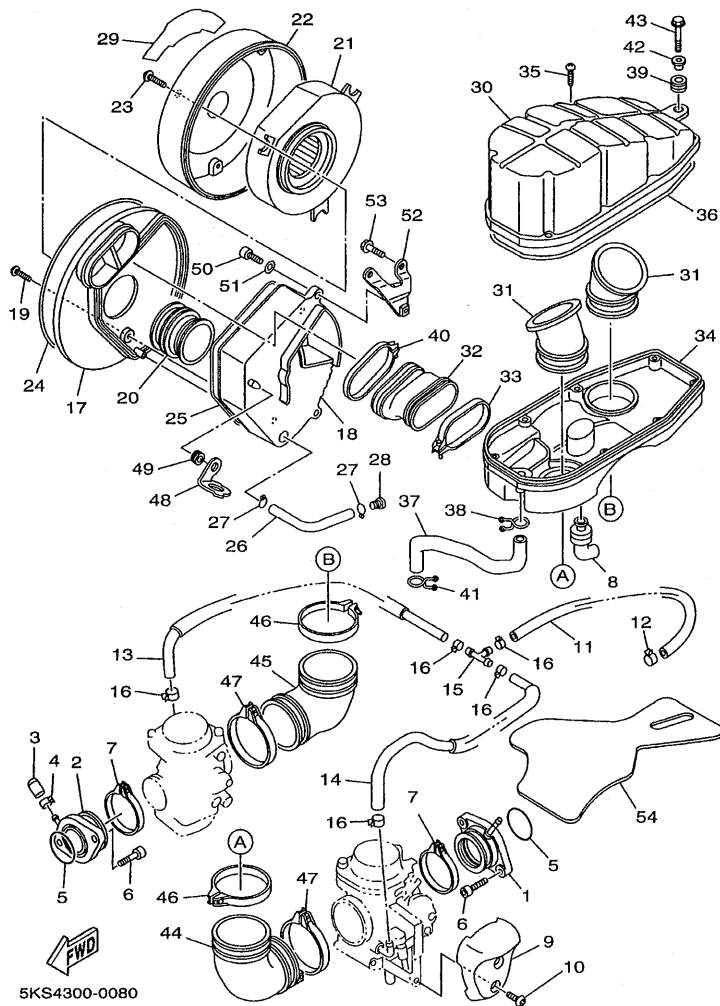
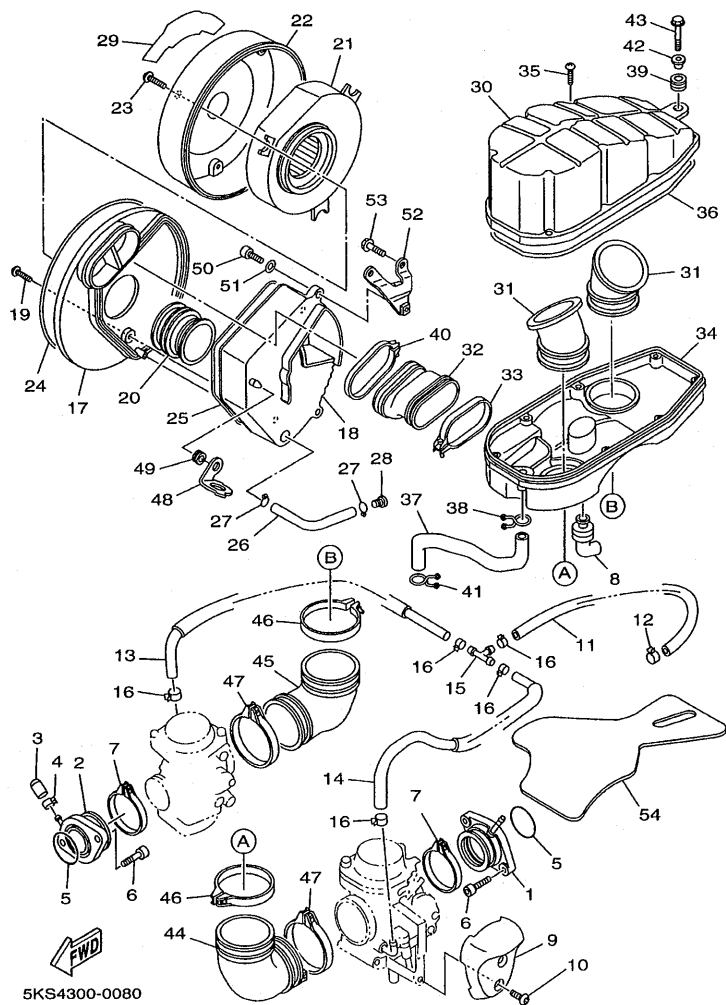


FIG. 8 ADMISION

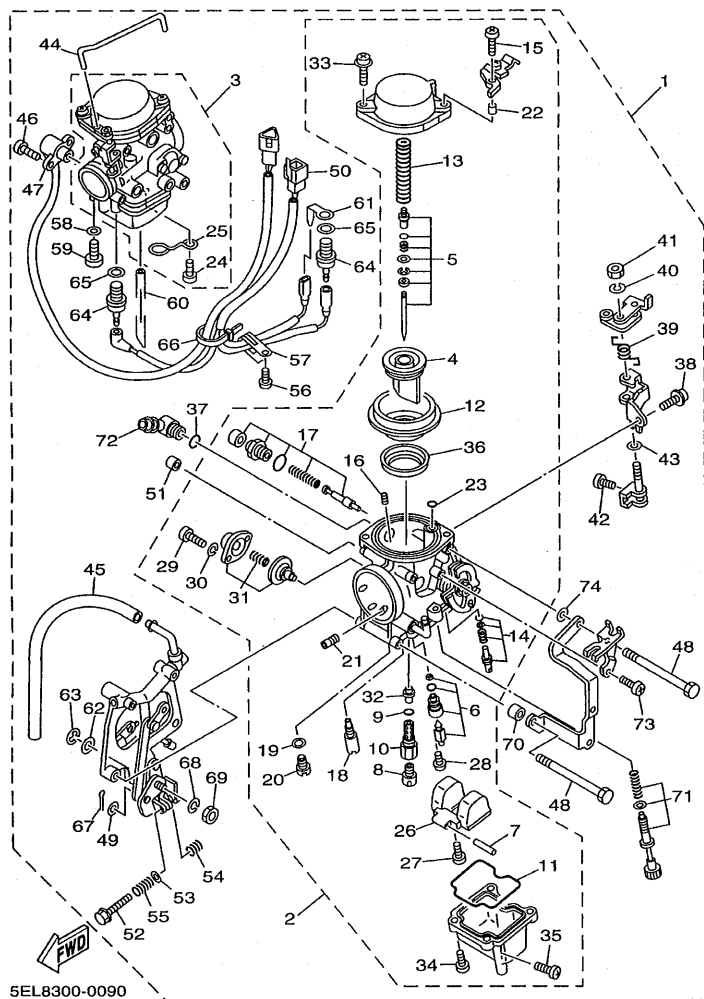
REF. NO.	CODIGO NO.	DESCRIPCION	5KSB				OBSERVACION
1	5EL-13586-00	TOBERA DE CARBURADOR 1	1				
2	5EL-13596-00	TOBERA DE CARBURADOR 2	1				
3	16G-13569-00	TAPON CIEGO	1				
4	90467-10039	PRESILLA	1				
5	93210-44545	ANILLO O	2				
6	91317-06020	PERNO	4				
7	5EL-13474-00	BANDA	2				
8	5EL-14987-00	TUBO	1				
9	5EL-14283-00	CUBIERTA DE CARBURADOR	1				
10	92014-05012	PERNO	2				
11	5EL-14294-00	MANGUERA	1				
12	90467-12191	PRESILLA	1				
13	5EL-14349-00	TUBO	1				
14	5EL-14348-00	MANGUERA	1				
15	90413-07007	UNION	1				
16	90467-10135	PRESILLA	5				
17	5EL-14411-00	CAJA FILTRO DEL AIRE 1	1				
18	5EL-14417-00	CUBIERTA 1	1				
19	97707-50116	TORNILLO ROSCA HEMBRA	4				
20	5EL-14437-00	CONDUCTO	1				
21	5EL-14451-00	ELEMENTO DEL FILTRO DEL AIRE	1				
22	5EL-14421-10	CAJA FILTRO DEL AIRE 2	1				
23	92014-05012	PERNO	3				
24	4TR-14452-00	SELLO	1				
25	5EL-14452-00	SELLO	1				
26	5EL-14148-00	TUBO	1				
27	90467-11106	PRESILLA	2				



5KS4300-0080

FIG. 8 ADMISION

REF. NO.	CODIGO NO.	DESCRIPCION	5KSB			OBSERVACION
28	90338-08174	TAPON	1			
29	5EL-1442K-00	EMBLEMA 2	1			
30	5EL-14431-00	SILENCIADOR DE ADMISION	1			
31	5EL-14454-00	PASADOR DE PALANCA	2			
32	5EL-1440F-00	UNION, FILTRO AIRE 1	1			
33	5EL-14455-00	BANDA	1			
34	5EL-14432-00	SILENCIADOR INTERNO	1			
35	97707-50125	TORNILLO ROSCA HEMBRA	8			
36	5EL-14462-00	SELLO	1			
37	5EL-11166-00	TUBO RESPIRADERO 1	1			
38	90467-14015	PRESILLA	1			
39	90480-12314	TAPON	1			
40	5EL-14455-00	BANDA	1			
41	90467-14015	PRESILLA	1			
42	90387-065J6	CASQUILLO CON VALONA	1			
43	95817-06020	TUERCA DE REBORDE	1			
44	5EL-14453-00	UNION DEL FILTRO DEL AIRE 1	1			
45	5EL-14463-00	UNION DE FILTRO DE AIRE 2	1			
46	90450-72095	BRIDA, MANGUERA	2			
47	90450-63096	BRIDA, MANGUERA	2			
48	5EL-14499-00	SOPORTE 2	1			
49	90480-13398	TAPON	1			
50	91317-06020	PERNO	2			
51	92907-06600	ARANDELA	2			
52	5EL-14414-00	SOPORTE 2	1			
53	95817-06010	TUERCA DE REBORDE	2			
54	5EL-12682-00	PROTECTOR	1			



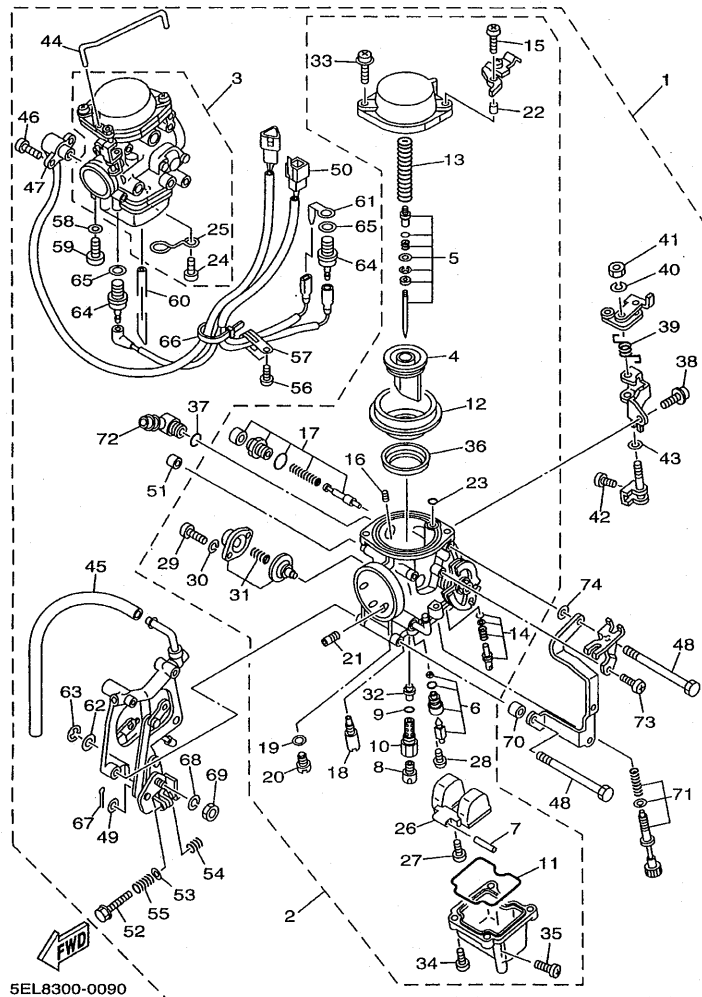
5EL8300-0090

FIG. 9 CARBURADOR

REF. NO.	CODIGO NO.	DESCRIPCION	5KSB			OBSERVACION
1	5KS-14900-00	CARBURADOR COMPLETO	1			
2	5KS-14901-00	..CARBURADOR COMPLETO 1	1			(#1) REAR
3	5KS-14902-00	..CARBURADOR COMPLETO 2	1			(#2) FRONT
4	5EL-14112-00	..VALVULA DE ACELERACION 1	1			
5	5KS-1490J-00	..CJTO. AGUJA	1			
6	5EL-14107-12	..VALVULA DE AGUJA	1			
7	127-14186-00	..PASADOR DE LA BOYA	1			
8	3G2-14231-22	..INYECTOR,PRINCIPAL (#110)	1			UR (#1) REAR
	3G2-1423A-73	..INYECTOR,PRINCIPAL (#112.5)	1			UR (#2) FRONT
9	583-14561-00	..ANILLO O	1			
10	5EL-14261-00	..SOSTEN	1			
11	5DM-14561-00	..ANILLO O	1			
12	5EL-24411-00	..DIAFRAGMA	1			
13	4KM-14933-00	..RESORTE DE DIAFRAGMA	1			
14	4XY-14105-00	..TORNILLO DE PILOTO	1			
15	98502-05016	..TORNILLO DE CABEZA CON PLAN	1			
16	1HX-14231-29	..INYECTOR,PRINCIPAL (#145)	1			
17	5EL-1410A-00	..JUEGO DE ARRANQUE	1			
18	4KM-14142-17	..SURTIDOR DE RALENTI (#17.5)	1			
19	5EL-14918-00	..ANILLO	1			
20	3G2-1423A-59	..INYECTOR,PRINCIPAL (#42.5)	1			
21	1HX-1423E-25	..INYECTOR PRINCIPAL	1			
22	4KM-14194-00	..ANILLO	1			(#1) REAR
23	354-14147-00	..ANILLO O	1			
24	98507-04012	..TORNILLO DE CABEZA CON PLAN	1			(#2) FRONT
25	5EL-14919-00	..PRESILLA	1			(#2) FRONT
26	5DM-14985-00	..BOIA	1			



FIG. 9 CARBURADOR



5EL8300-0090

REF. NO.	CODIGO NO.	DESCRIPCION	5KSB		OBSERVACION
27	98507-04008	..TORNILLO DE CABEZA CON PLAN	1		
28	1FN-14565-00	..TORNILLO	1		
29	98507-04014	..TORNILLO DE CABEZA CON PLAN	2		
30	92907-04100	..ARANDELA	2		
31	5EL-1490H-00	..DIAFRAGMA	1		
32	5DM-14141-40	..BOQUILLA PRINCIPAL	1		
33	4KM-14216-00	..TORNILLO	1		UR (#1) REAR
	4KM-14216-00	..TORNILLO	2		UR (#2) FRONT
34	98507-04010	..TORNILLO DE CABEZA CON PLAN	4		UR (#1) REAR
	98507-04010	..TORNILLO DE CABEZA CON PLAN	3		UR (#2) FRONT
35	12R-14191-00	..TORNILLO, DE DRENAJE	1		
36	5EL-14561-00	..ANILLO O	1		
37	3LN-1416A-00	..ANILLO O	2		
38	4SV-24453-00	..TORNILLO	2		
39	5EL-14935-00	..RESORTE	2		
40	92902-05100	..ARANDELA	2		
41	95302-05700	..TUERCA	2		
42	11H-14991-00	..TORNILLO	2		
43	31H-14194-00	..ANILLO	4		
44	5EL-14577-00	..VARILLA	1		
45	4YW-14987-00	..TUBO	1		
46	4WM-14565-00	..TORNILLO	2		
47	5EL-85885-00	..TERMICA SENSORIO	1		
48	5EL-14592-00	..TORNILLO	4		
49	4NK-14285-00	..ARANDELA	1		
50	5EL-81517-00	..CABLE SUB CONDUCTOR	1		
51	5EL-14987-00	..TUBO	2		

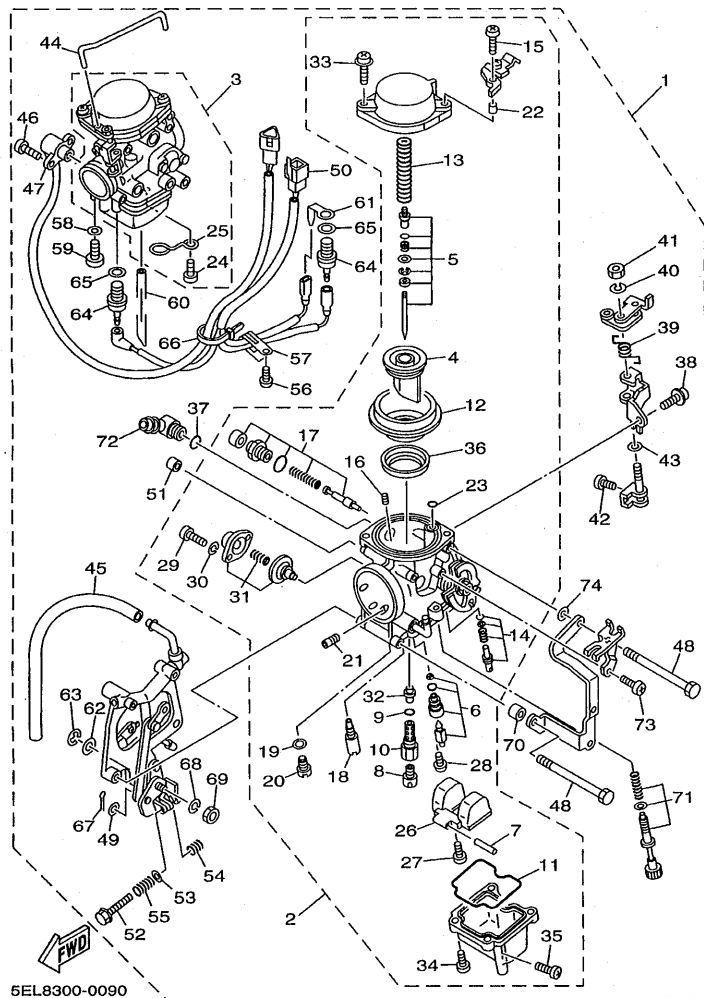


FIG. 9 CARBURADOR

REF. NO.	CODIGO NO.	DESCRIPCION	5KSB				OBSERVACION
52	5EL-14991-00	.TORNILLO	1				
53	22F-14117-00	.ARANDELA TAPON DE TORNILLO	1				
54	5EL-14212-00	.RESORTE DE AJUSTE DE PILOTO	1				
55	3F7-14133-00	.RESORTE TOPE DE ACELERACION	1				
56	98507-04006	.TORNILLO DE CABEZA CON PLANA	1				
57	90461-06087	.GRAPA	1				
58	127-14198-00	.EMPAQUE	2				
59	3DM-14216-00	.TORNILLO	2				
60	5EL-14197-00	.TUBO RESPIRADERO	2				
61	4DH-82103-00	.TERMINAL 1	1				
62	1A8-14953-00	.ARANDELA	1				
63	812-14137-00	.PRESILLA	1				
64	3BT-83790-00	.CALENTADOR (30W)	2				
65	5CY-14951-00	.ARANDELA	2				
66	35H-14139-00	.PRESILLA TUBO	2				
67	91492-10008	.PASADOR DE CHAVETA	4				
68	92906-06100	.ARANDELA	1				
69	95382-06700	.TUERCA	1				
70	5EL-14149-00	.TUBO	1				
71	5EL-14103-00	.CJTO. TORNILLO DEL RALENTI	1				
72	5EL-14251-00	.NIPLE	1				
73	98507-04010	.TORNILLO DE CABEZA CON PLANA	1				
74	92902-06600	.ARANDELA	1				

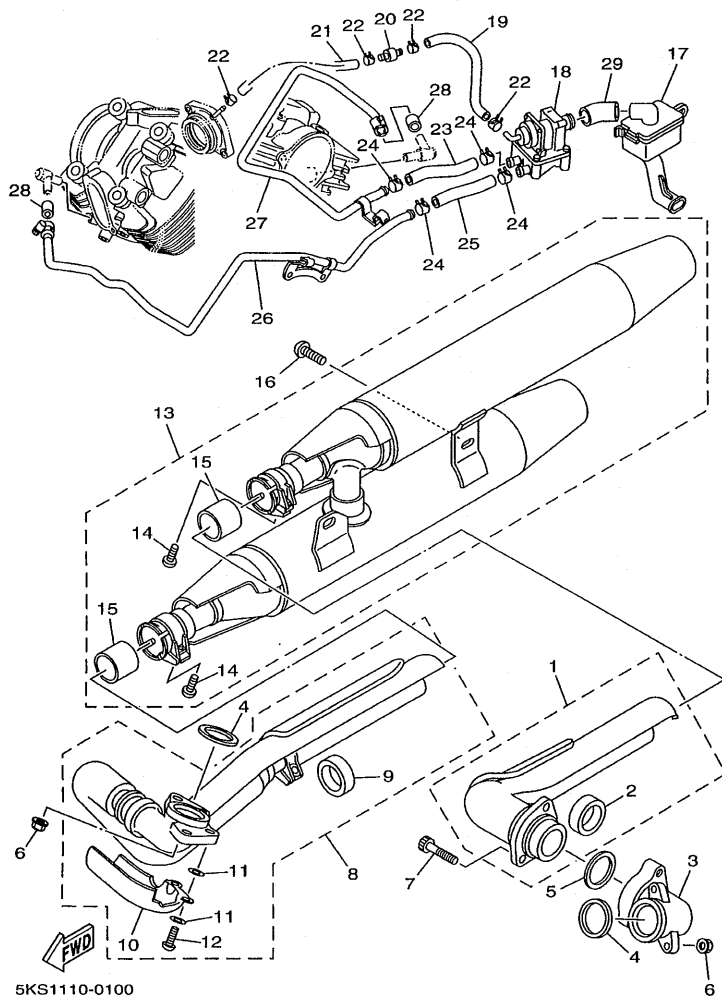
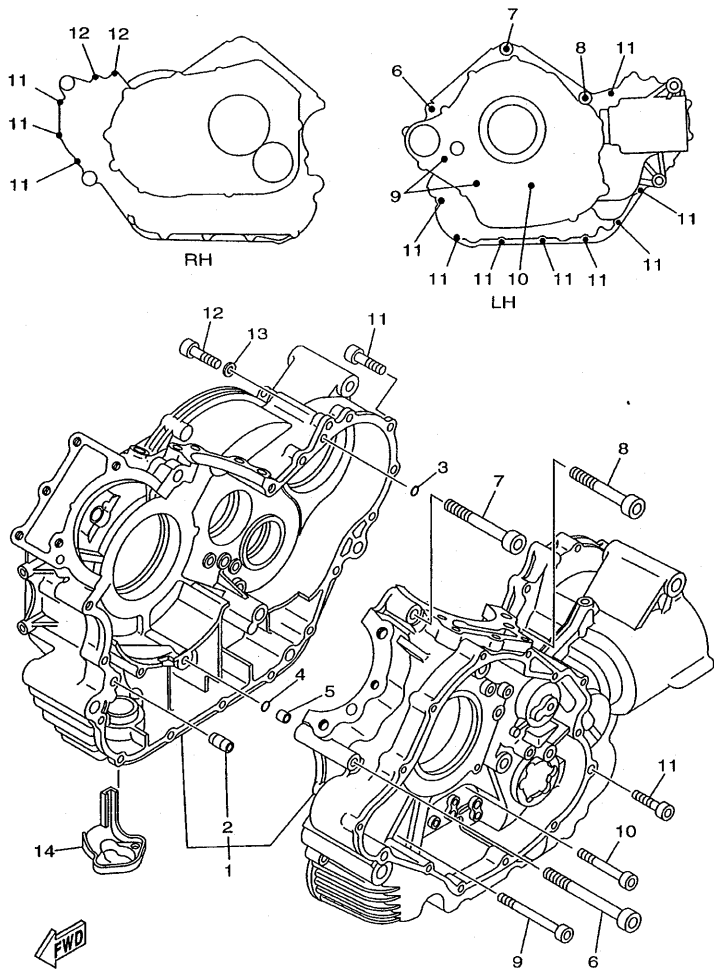


FIG. 10 DESCARGA

REF. NO.	CODIGO NO.	DESCRIPCION	5KSB				OBSERVACION
1	5EL-14610-10	TUBO DE ESCAPE COMPLETO 1	1				
2	4NK-14714-00	.EMPAQUE DE SILENCIADOR	1				
3	5EL-14615-00	EMPAQUE DE ESCAPE 1	1				
4	3EG-14613-00	JUNTA, TUBO DE ESCAPE	2				
5	4TR-14613-00	JUNTA, TUBO DE ESCAPE	1				
6	90185-08097	TUERCA AUTOBLOCANTE	4				
7	91314-08035	PERNO	2				
8	5KS-14620-00	TUBO DE ESCAPE COMPLETO 2	1				
9	4NK-14714-00	.EMPAQUE DE SILENCIADOR	1				
10	5EL-14624-00	.CUBIERTA ESCAPE	1				
11	90202-05191	.ARANDELA DE PLANA	4				
12	98904-06014	.TORNILLO DE LIGAR	2				
13	5EL-14710-30	TUBO DE ESCAPE COMPLETO 1	1				
14	92017-08020	.PERNO	2				
15	3XW-14755-00	.EMPAQUE DE SILENCIADOR	2				
16	92017-10020	PERNO	2				
17	5EL-14806-00	FILTRO DE AIRE COMPLETO	1				
18	5EL-14803-10	VALVULA DE AIRE COMPLETA	1				
19	5EL-13544-01	TUBO PARA SENTIR DEPRESION	1				
20	41R-14489-00	BOQUILLA	1				
21	5EL-13542-00	TUBO PARA SENTIR DEPRESION	1				
22	90467-08092	PRESILLA	4				
23	5EL-14882-00	TUBO 2	1				
24	90468-08104	PRESILLA	4				
25	5EL-14884-00	TUBO 4	1				
26	5EL-14872-00	TUBO 2	1				
27	5EL-14871-00	TUBO DE COMBUSTIBLE	1				



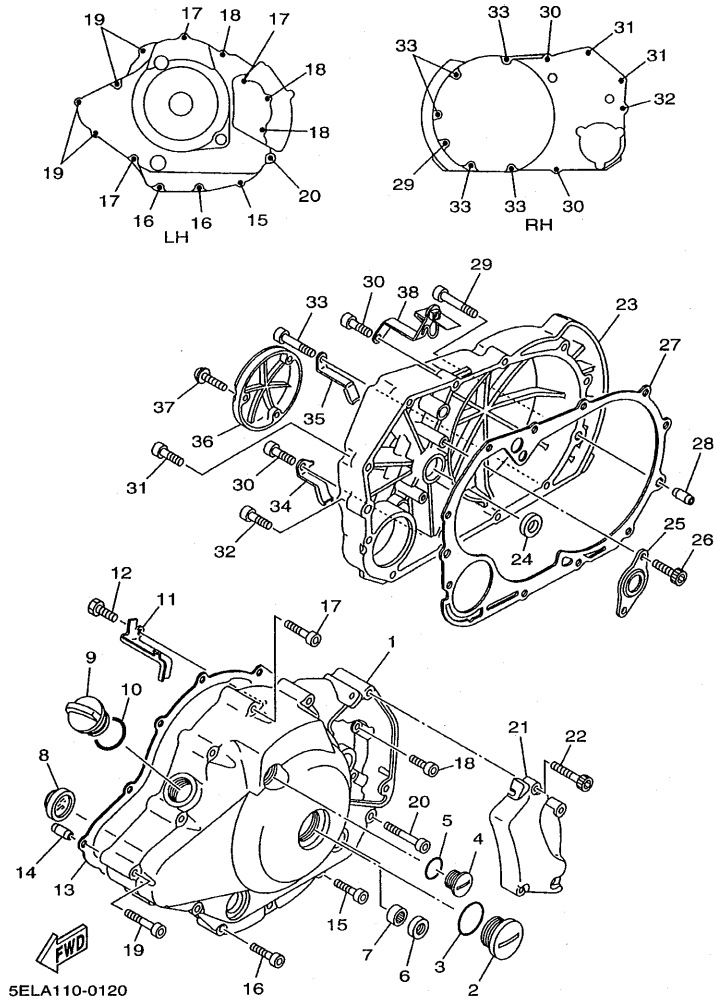


5EL1351-9110

FIG. 11 CARTER

REF. NO.	CODIGO NO.	DESCRIPCION	5K9B				OBSERVACION
1	5KS-15100-00	CARTER COMPLETO	1				
2	99530-14016	.PASADOR, DE ESPIGA	3				
3	93210-07135	ANILLO O	1				
4	93210-07135	ANILLO O	1				
5	90387-064E8	CASQUILLO CON VALONA	1				
6	91317-10100	PERNO	1				
7	91317-10070	PERNO	1				
8	91317-10060	PERNO	1				
9	91317-06080	PERNO	2				
10	91317-06055	PERNO	1				
11	91317-06030	PERNO	11				
12	91314-06030	PERNO	2				
13	90430-06014	JUNTA	1				
14	4X7-15491-00	PROTECTOR	1				

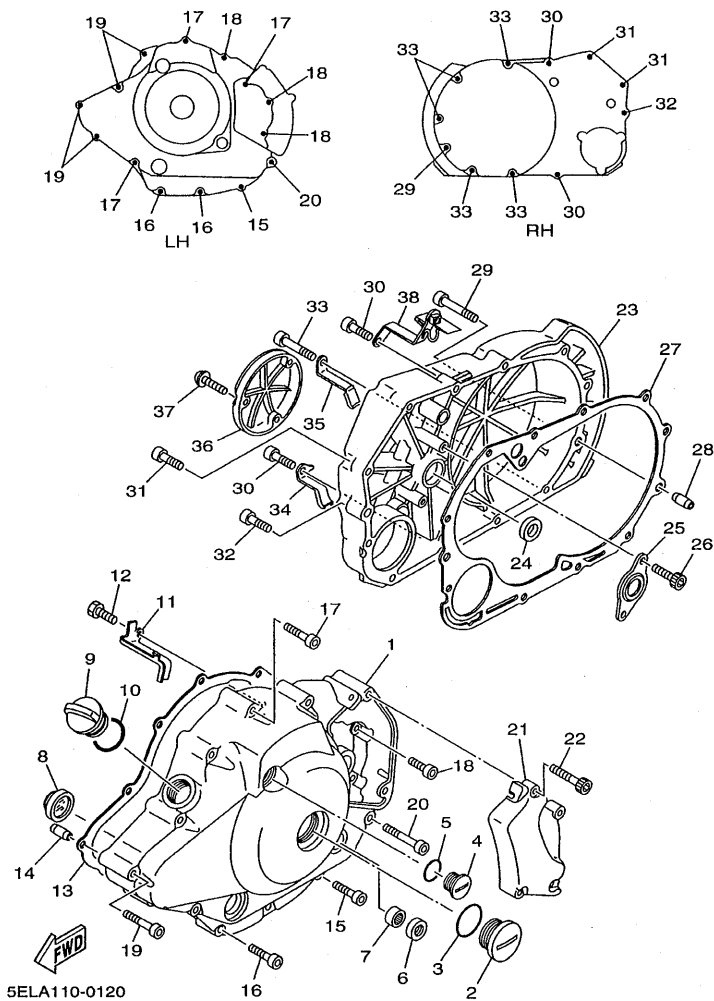
FIG. 12 CUBIERTA DE CARTER 1



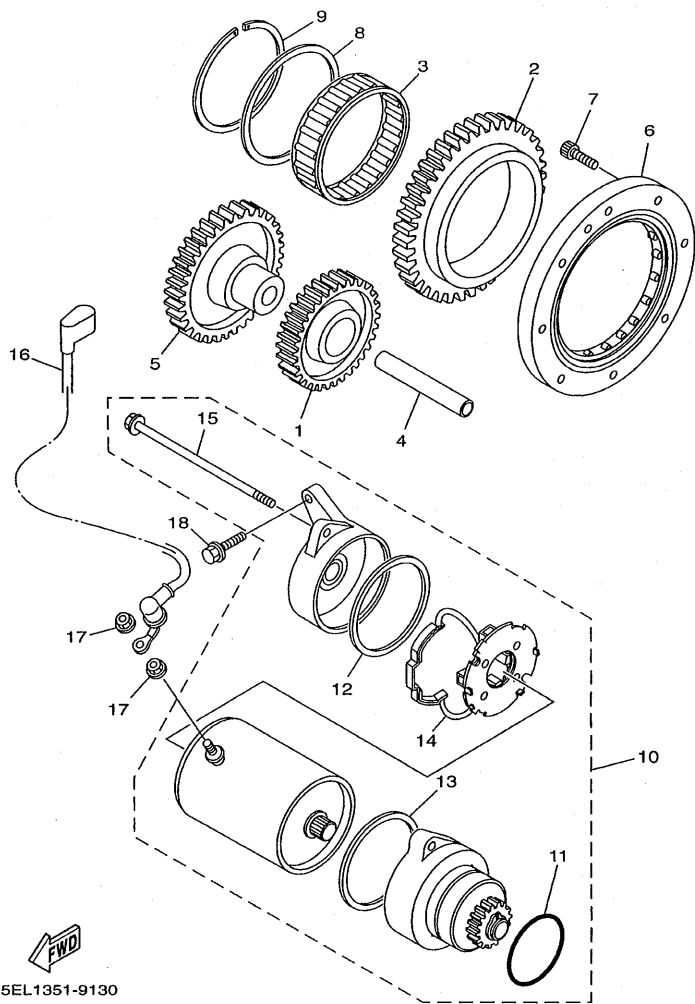
5ELA110-0120

REF. NO.	CODIGO NO.	DESCRIPCION	5KSB				OBSERVACION
1	5EL-15411-00	CUBIERTA DE CARTER 1	1				
2	90340-32140	TORNILLO, DE DRENAJE	1				
3	93210-32172	ANILLO O	1				
4	90340-14153	TORNILLO, DE DRENAJE	1				
5	93210-14369	ANILLO O	1				
6	93102-12106	SELLO ACEITE (SD 12-22-5 HS)	1				
7	93317-21236	COJINETE	1				
8	2H7-15361-00	MEDIDOR DE NIVEL	1				
9	3F9-15362-00	TAPON DEL NIVEL DE ACEITE	1				
10	93210-27370	ANILLO O	1				
11	5EL-15484-00	GRAMPA 2	1				
12	91317-06012	PERNO	1				
13	5EL-15451-00	EMPAQ DE CUBIERTA DE CARTER	1				
14	99530-10114	PASADOR, DE ESPIGA	2				
15	91314-06035	PERNO	1				
16	91314-06030	PERNO	2				
17	91314-06045	PERNO	3				
18	90110-06003	TORNILLO ALLEN	3				
19	91314-06055	PERNO	4				
20	91314-06065	PERNO	1				
21	5EL-15417-00	CUBIERTA DE TAPA	1				
22	91314-06030	PERNO	3				
23	5EL-15421-00	TAPA DE CARTER DERECHA	1				
24	93101-14102	SELLO ACEITE	1				
25	4X7-15388-00	PLACA DE CUBIERTA DE COJINETE	1				
26	91314-06016	PERNO	2				
27	5EL-15462-00	EMPAQ CUBIERTA DE CARTER 3	1				

FIG. 12 CUBIERTA DE CARTER 1



REF. NO.	CODIGO NO.	DESCRIPCION	5K5B				OBSERVACION
28	99530-10120	PASADOR, DE ESPIGA	2				
29	91314-06060	PERNO	1				
30	91314-06035	PERNO	2				
31	90110-06006	TORNILLO ALLEN	2				
32	91314-06040	PERNO	1				
33	91314-06055	PERNO	5				
34	90462-10003	BRIDA	1				
35	90462-10247	BRIDA	1				
36	5EL-15423-00	CUBIERTA 2	1				
37	92014-06020	PERNO	3				
38	5EL-14413-00	SOPORTE	1				



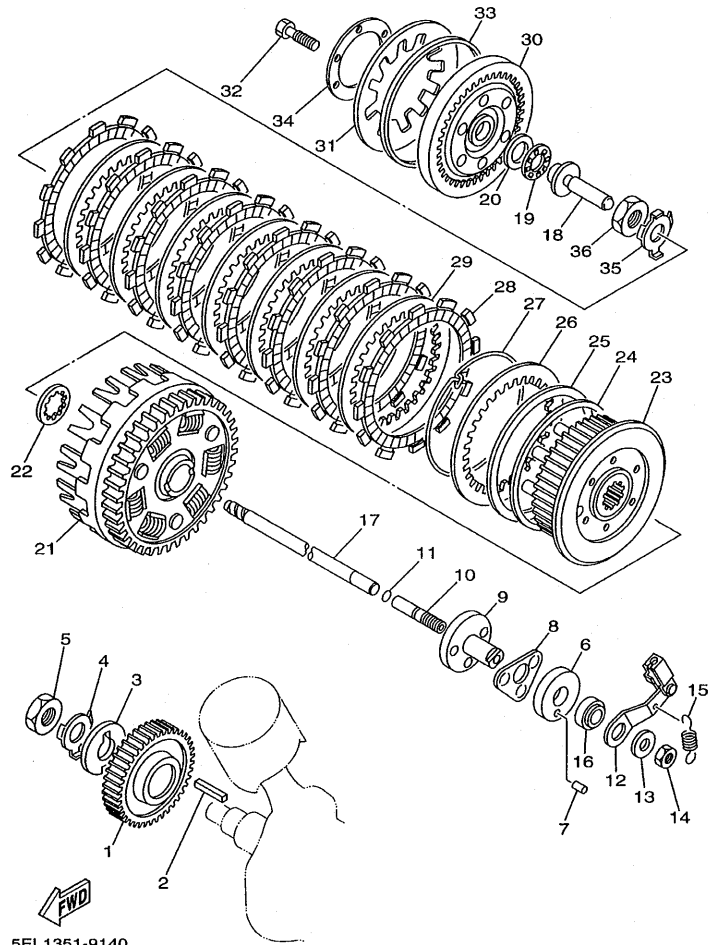
**FWD**  
5EL1351-9130

**FIG. 13 ARRANQUE**

REF. NO.	CODIGO NO.	DESCRIPCION	9K/SB				OBSERVACION
1	5EL-15515-00	ENGRANAJE 3	1				
2	5EL-15517-10	ENGRANAJE POSICION 2DA	1				
3	93310-5720G	COJINETE	1				
4	24W-15521-00	EJE 1	1				
5	5EL-15512-00	ENGRANAJE NEUTRO	1				
6	5EL-15590-00	ENSAMBLE GUIA CADENA ARRANQUE	1				
7	91317-06016	PERNO	8				
8	90201-72008	ARANDELA PLANA	1				
9	93440-68180	BOLA	1				
10	5EL-81890-00	MOTOR DE ARRANQUE COMPLETO	1				
11	1J7-81847-80	.ANILLO GOMA	1				
12	11H-81844-00	.EMPAQUE	1				
13	4G0-81844-00	.EMPAQUE	1				
14	5A8-81840-10	.SOSTEN DE ESCOBILLA COMPLETO	1				
15	3KM-81826-00	.PERNO	2				
16	5EL-81815-00	CABLE, MOTOR DE ARRANQUE	1				
17	4XV-8182A-00	TUERCA	2				
18	95814-06025	TUERCA DE REBORDE	2				

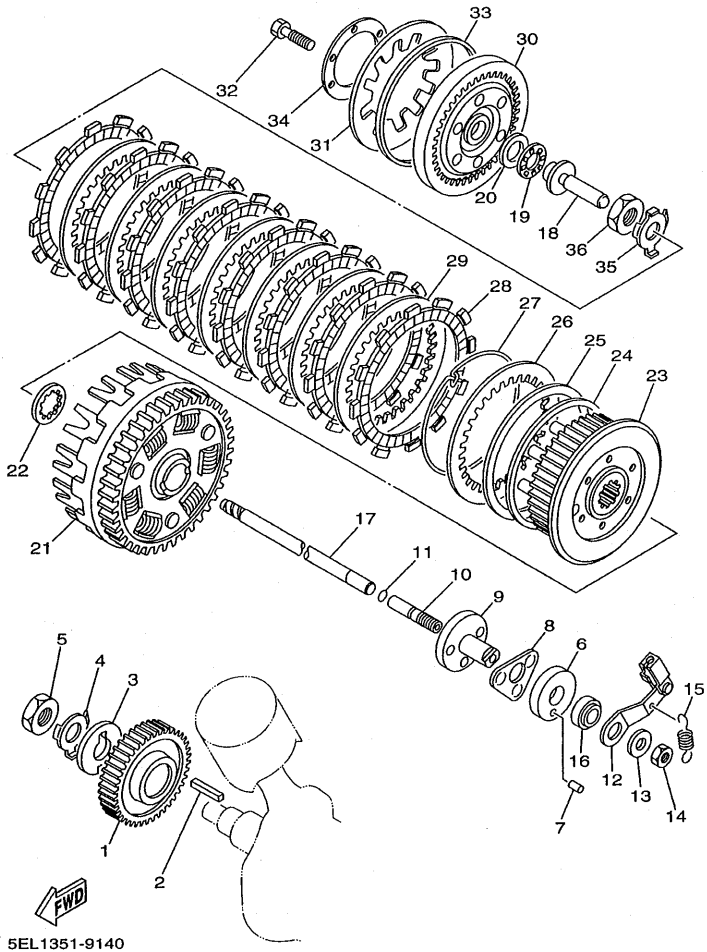


FIG. 14 EMBRAGUE



5EL1351-9140

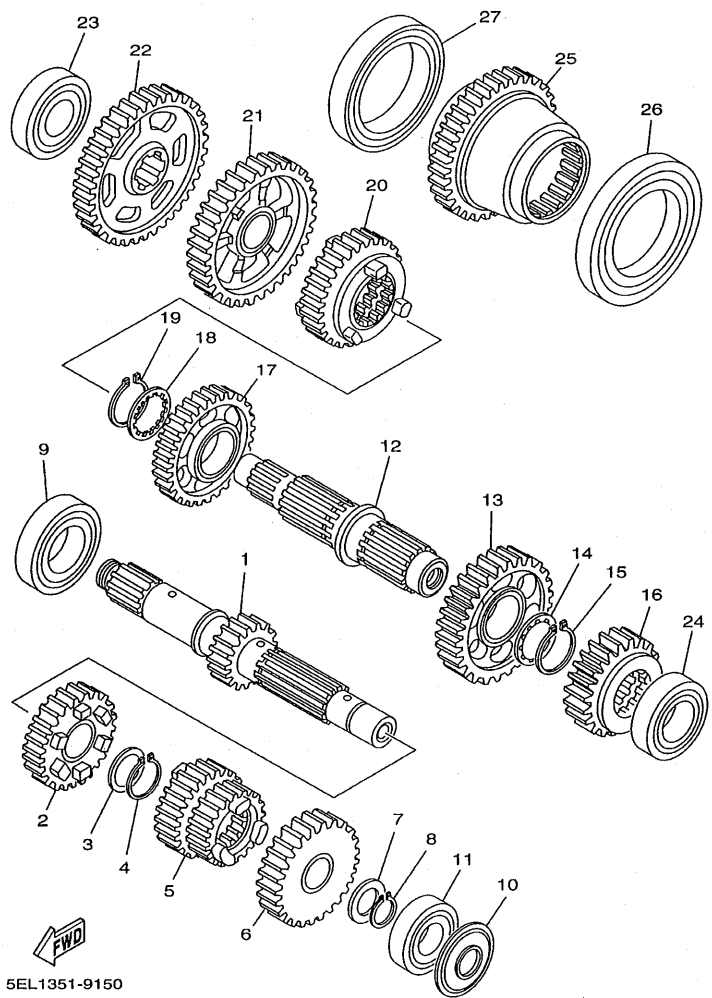
REF. NO.	CODIGO NO.	DESCRIPCION	5K98				OBSERVACION
1	4X7-16111-00	ENGRANAJE TRACC.PRIMARIA (47T)	1				
2	90282-07042	CHAVETA, RECTA	1				
3	90214-20022	ARANDELA DE POSICION	1				
4	90215-20182	ARANDELA DE CIERRE	1				
5	90170-20274	TUERCA	1				
6	2H7-16396-00	CAJA DE TORNILLO DE EMPUJE	1				
7	93606-07082	PASADOR DE CLAVIJA	1				
8	2H7-16395-01	RETEN DE BOLA	1				
9	2H7-16341-00	TORNILLO DE EMPUJE	1				
10	2H7-16343-00	TORNILLO DE AJUSTE	1				
11	93210-48364	ANILLO O	1				
12	5EL-16340-00	PALANCA DE EMPUJE COMPLETA	1				
13	92907-08200	ARANDELA	1				
14	95307-08700	TUERCA	1				
15	90506-10069	RESORTE DE TENSION	1				
16	93104-14059	SELLO ACEITE	1				
17	5EL-16357-00	VARILLA DE EMPUJE 2	1				
18	4X7-16356-00	VARILLA DE EMPUJE 1	1				
19	93340-21505	COJINETE	1				
20	90201-151A7	ARANDELA PLANA	1				
21	4X7-16150-02	CAMPAÑA DE EMBRAGUE	1				
22	2JN-16154-00	ARANDELA, DE EMPUJE 1	1				
23	5EL-16371-00	CUBO, DE EMBRAGUE	1				
24	4X7-16384-00	PLACA DE ASIENTO	1				
25	4X7-16383-01	RESORTE DE COPA DE EMBRAGUE	1				
26	4X7-16324-00	PLACA DE EMBRAGUE	1				
27	4X7-16385-00	RESORTE DE COPA DE EMBRAGUE	1				



5EL1351-9140

FIG. 14 EMBRAGUE

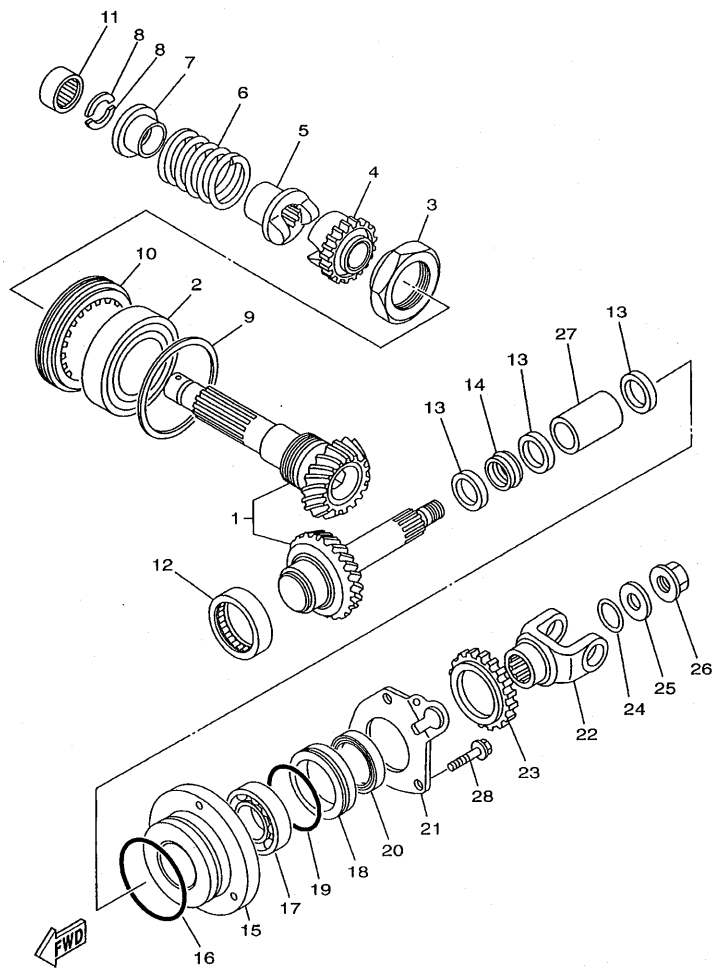
REF. NO.	CODIGO NO.	DESCRIPCION	9K5B				OBSERVACION
28	22U-16321-00	PLACA DE FRICCION	8				
29	1TA-16325-00	DISCO, DE EMBRAGUE	7				
30	1TA-16351-01	PLATO DE PRESION	1				
31	1TA-16334-00	RESORTE DE EMBRAGUE 2	1				
32	97027-06025	PERNO	6				
33	1TA-16335-00	CAJA DE RESORTE	1				
34	1TA-16352-00	PLACA DE PRESION 2	1				
35	90215-20170	ARANDELA DE CIERRE	1				
36	90170-20257	TUERCA	1				



5EL1351-9150

FIG. 15 TRANSMISION

REF. NO.	CODIGO NO.	DESCRIPCION	5KSB				OBSERVACION
1	5EL-17411-00	EJE PRIMARIO	1				
2	5EL-17141-00	ENGRANAJE PINON DE 4TA (31T)	1				
3	90209-21332	ARANDELA DE SEPARACION	1				
4	99009-25400	PRESILLA REDONDA	1				
5	5EL-17121-00	ENGRANAJE DE PINON DE 2DA (24T/28T)	1				
6	5EL-17151-00	ENGRANAJE PINON DE 5TA (34T)	1				
7	90201-20276	ARANDELA, PLACA (1.0T)	1				
8	99009-20400	PRESILLA REDONDA	1				
9	93306-30525	COJINETE (B6305)	1				
10	93104-20068	SELLO ACEITE	1				
11	93306-30424	COJINETE (B6304A3)	1				
12	5EL-17402-00	EJE DE TRACCION COMPLETO	1				
13	5EL-17221-00	ENGRANAJE RUEDA DE 2DA (40T)	1				
14	90209-28331	ARANDELA DE SEPARACION	1				
15	93440-31172	BOLA	1				
16	5EL-17251-00	ENGRANAJE RUEDA DE 5TA (29T)	1				
17	5EL-17231-00	ENGRANAJE RUEDA DE 3RA (36T)	1				
18	90209-28331	ARANDELA DE SEPARACION	1				
19	93440-31172	BOLA	1				
20	5EL-17241-00	ENGRANAJE DE RUEDA 4TA (32T)	1				
21	4X7-17211-00	ENGRANAJE RUEDA DE 1 RA (40T)	1				
22	5EL-17582-00	ENGRANAJE MEDIO DE TRACCION (47T)	1				
23	93306-20401	COJINETE (B6204)	1				
24	93306-20550	COJINETE (B6205DU8)	1				
25	5EL-17583-00	ENGRANAJE MEDIO DE IMPULSION (25T)	1				
26	93316-01201	COJINETE (B16012)	1				
27	93306-91201	COJINETE (B6912)	1				



5EL1351-9160

FIG. 16 ENGR. MEDIO DE TRAC.

REF. NO.	CODIGO NO.	DESCRIPCION	BK/SB			OBSERVACION
1	5EL-Y1757-00	ENGRANAJE MEDIO COMPLETE	1			
2	93306-20901	COJINETE (B6209RSH2-C2)	1			
3	90179-44328	TUERCA	1			
4	42X-17526-01	LEVA DE TRACCION	1			
5	31A-17527-00	LEVA DE IMPULSION	1			
6	90501-70762	RESORTE DE COMPRESION	1			
7	4X7-17524-00	SOSTEN	1			
8	3H5-17529-00	ARANDELA DE EMPUJE	2			
9	4X7-17531-00-15	CUNA DE PINON (0.15T)	1			UR
	4X7-17531-00-30	CUNA DE PINON (0.30T)	1			UR
	4X7-17531-00-50	CUNA DE PINON (0.50T)	1			UR
10	90179-88336	TUERCA	1			
11	93317-22021	COJINETE	1			
12	93311-44051	COJINETE	1			
13	90201-255A6	ARANDELA PLANA	3			
14	1J7-46129-Y1	ESPACIADOR DE EXPANSION	1			
15	4X7-17551-00	CAJA DE COJINETE	1			
16	93210-71360	ANILLO O	1			
17	93306-20548	COJINETE (B6205RC2)	1			
18	4X7-17554-00	RETEN DE COJINETE	1			
19	93210-52449	ANILLO O	1			
20	93101-35099	SELLO ACEITE	1			
21	5EL-17558-00	PLACA	1			
22	5EL-17556-00	YUGO DE ARTICULACION	1			
23	5EL-8135E-00	ROTOR	1			
24	93210-14359	ANILLO O	1			
25	90201-14633	ARANDELA PLANA	1			

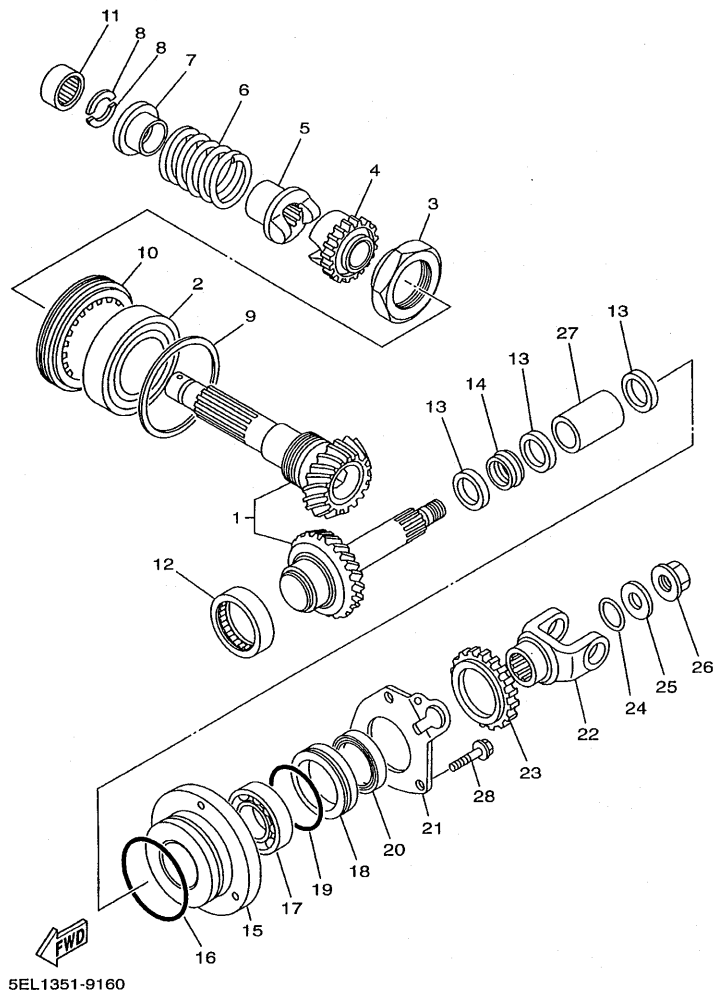


FIG. 16 ENGR. MEDIO DE TRAC.

REF. NO.	CODIGO NO.	DESCRIPCION	5K5B				OBSERVACION
26	90179-14317	TUERCA	1				
27	90387-251E1	CASQUILLO CON VALONA	1				
28	90105-08010	TORNILLO CON ARANDELA	3				

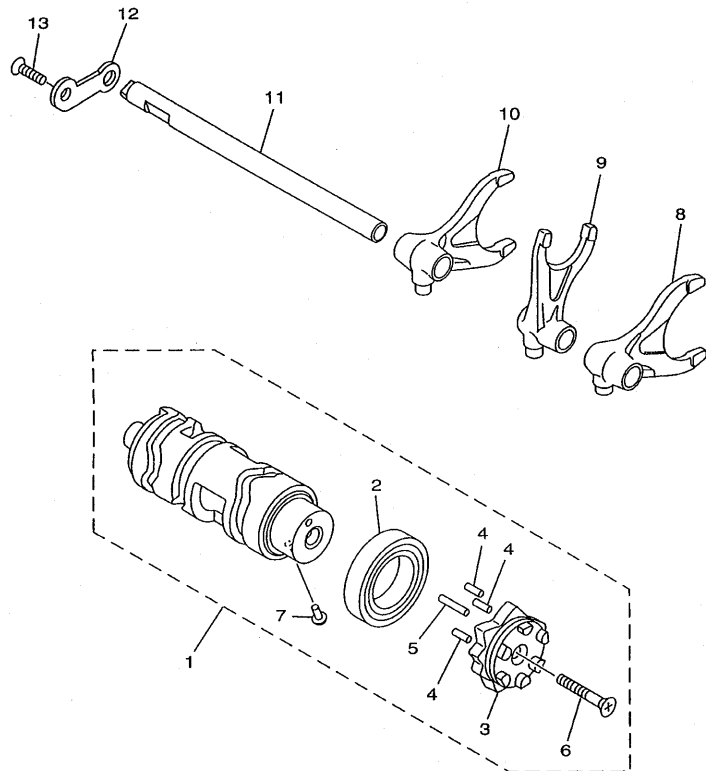


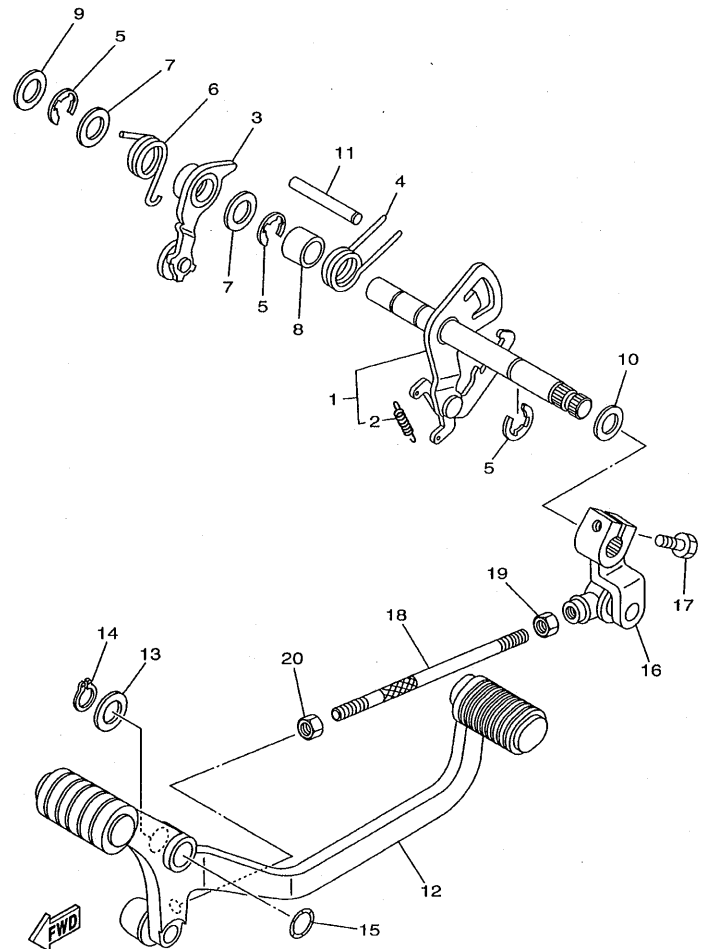
FIG. 17 LEVA DE CAMBIO. HORQ

REF. NO.	CODIGO NO.	DESCRIPCION	9KXSB				OBSERVACION
1	5EL-18540-00	LEVADEL CAMBIO COMPLETA	1				
2	93306-90602	.COJINETE	1				
3	5EL-18185-00	.SEGMENTO DE RETENCION	1				
4	93604-16092	.PASADOR DE CLAVIJA	3				
5	93604-20156	.PASADOR DE CLAVIJA	1				
6	98707-05035	.TORNILLO DE CABEZA PLANA	1				
7	136-18542-00	.PUNTO MVERTO	1				
8	5EL-18511-00	HORQUILLA DEL CAMBIO 1	1				
9	5EL-18512-00	HORQUILLA DEL CAMBIO 2	1				
10	5EL-18513-00	HORQUILLA DE CAMBIO 3	1				
11	5EL-18531-00	BARRA GUIA HORQ. CAMBIO 1	1				
12	4X7-18536-00	TOPE DE PALANCA SELECTOR	1				
13	90151-06041	TORNILLO EMBUTIDO	2				



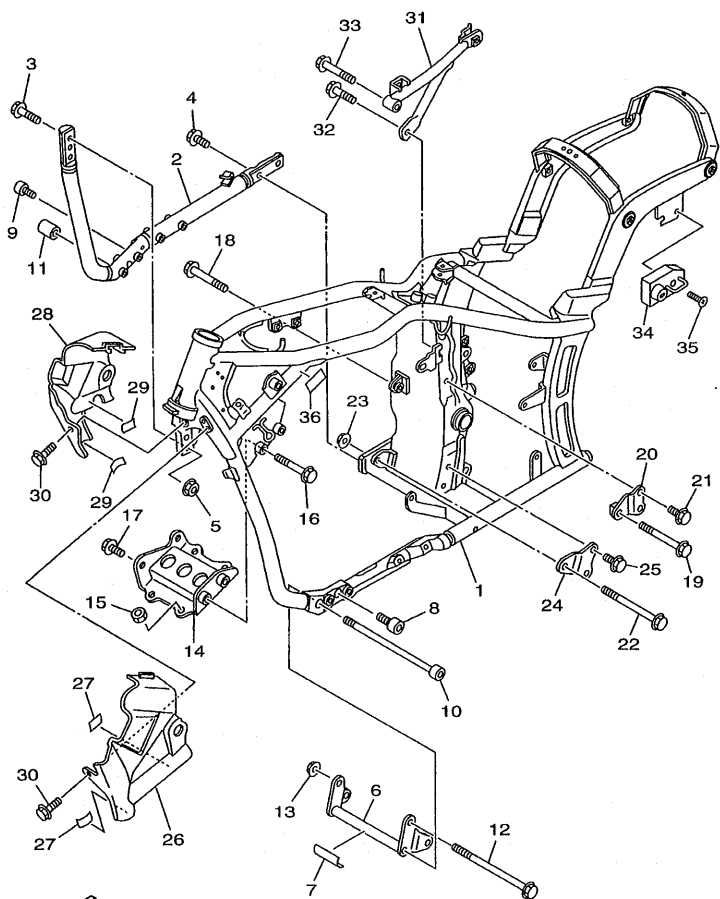
5EL1351-9170

FIG. 18 EJE DE CAMBIO. PEDAL



5KS1110-0180

REF. NO.	CODIGO NO.	DESCRIPCION	5KSB				OBSERVACION
1	5EL-18120-00	PALANCA DE SELECTOR COMPLETO	1				
2	90506-08227	.RESORTE DE TENSION	1				
3	5EL-18140-00	PALANCA DE TOPE COMPLETA	1				
4	90508-32535	RESORTE DE TORSION	1				
5	99001-10600	PRESILLA REDONDA	3				
6	90508-32012	RESORTE DE TORSION	1				
7	90201-12588	ARANDELA PLANA	2				
8	90387-124F4	CASQUILLO CON VALONA	1				
9	90201-12588	ARANDELA PLANA	1				
10	90201-12166	ARANDELA PLANA	1				
11	93608-50158	PASADOR DE CLAVIJA	1				
12	5KS-18110-00	PEDAL DE CAMBIO COMPLETO	1				
13	90201-12688	ARANDELA PLANA	1				
14	99009-12400	PRESILLA REDONDA	1				
15	90206-12074	ARANDELA ONDULADA	1				
16	4TR-18112-00	BRAZO DEL CANBIO	1				
17	97024-06020	PERNO	1				
18	4DN-18115-20	VARILLA DEL CANBIO	1				
19	90170-06228	TUERCA	1				
20	95304-06700	TUERCA	1				



5KS3171-0190

FIG. 19 CUADRO

REF. NO.	CODIGO NO.	DESCRIPCION	5KSB				OBSERVACION
1	5KS-21110-00	ARMAZON COMPLETO	1				Go to P/N: PE0-MC-050086
2	5EL-21150-00	CONJ. TUBO INFERIOR 2	1				
3	90105-10009	TORNILLO CON ARANDELA	2				
4	90105-10004	TORNILLO CON ARANDELA	2				
5	95607-10200	TUERCA DE AUTO-CIERRE	2				
6	5EL-21318-00	SOPORTE DE MOTOR 5	1				
7	4DN-21268-00	SELLO	1				
8	91317-10020	PERNO	1				
9	91317-10030	PERNO	1				
10	90110-10182	TORNILLO ALLEN	1				
11	90179-10377	TUERCA	1				
12	90105-10781	TORNILLO CON ARANDELA	1				
13	95607-10200	TUERCA DE AUTO-CIERRE	1				
14	5EL-21317-00	SOPORTE DE MOTOR 3	1				
15	90179-12657	TUERCA	4				
16	90105-100A4	TORNILLO CON ARANDELA	2				
17	90105-10003	TORNILLO CON ARANDELA	2				
18	90105-10013	TORNILLO CON ARANDELA	1				
19	90105-10299	TORNILLO CON ARANDELA	1				
20	5EL-21314-00	SOPORTE DE MOTOR 5	1				
21	95817-10016	TUERCA DE REBORDE	2				
22	90105-10444	TORNILLO CON ARANDELA	1				
23	95607-10200	TUERCA DE AUTO-CIERRE	1				
24	5EL-21316-00	SOPORTE DE MOTOR 3	1				
25	95817-10016	TUERCA DE REBORDE	2				
26	5EL-2171E-00	CUBIERTA LATERAL 5	1				
27	3BN-21747-00	AMORTIGUADOR	2				





# PARTS NEWS

News No. PE0-MC-050086(1/2)

Date: Sep,19,2005

Signature: K.Otsuka

Model	XVS1100A (See the "List of Models and CATALOGUE No's ."of the next page.)
Subject	PARTS CATALOGUE MODIFICATION
CATALOGUE NO.	See the "List of Models and CATALOGUE No's ."of the next page.

Please make the following corrections to your parts catalogue.

## 1. LIST CORRECTION

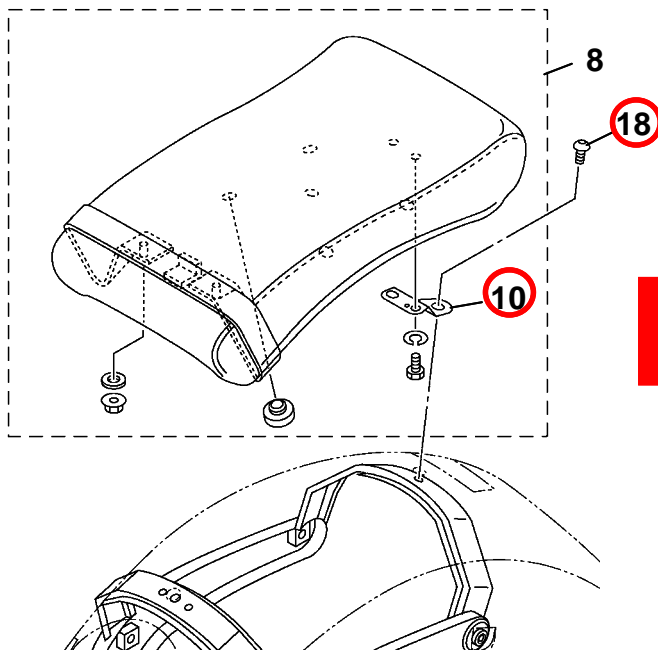
FIG. 19 FRAME & FIG. 27 SEAT

FIG.No.	Ref.No.	OLD P/No.	NEW P/No.	PARTS NAME	Q'TY	REMARKS
19	1	5KS-21110-00	<b>5KS-21110-03</b>	FRAME COMP.	1	
27	8	5KS-24750-00	<b>5KS-24750-30</b>	TANDEM SEAT ASSY	1	
27	8-1	————	<b>5YS-24742-00</b>	. GROMMET	1	<b>added</b>
27	8-2	————	<b>5YS-2471N-00</b>	COLLAR, 1	1	<b>added</b>
27	8-3	————	<b>90201-08042</b>	WASHER, PLAIN	1	<b>added</b>
27	8-4	————	<b>90176-08001</b>	NUT, CAP	1	<b>added</b>
27	10	5BN-2475J-00	<b>5YS-2475J-00</b>	. BRACKET, SEAT LEVER 2	1	
27	18	92014-08012	————	BOLT, BUTTON HEAD	1	<b>delete</b>

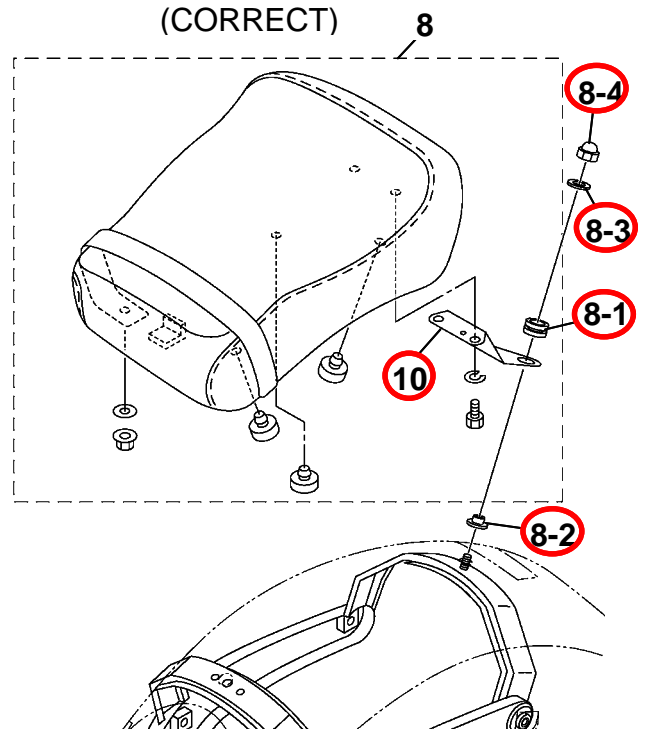
## 2. ILLUSTRATION CORRECTION

Illustration should be read as follows.

(INCORRECT)



(CORRECT)



Parts  
Manager  
Check

Service  
Manager  
Check

Parts  
Manager  
File

YAMAHA MOTOR CO.,LTD  
 2500 Shingai Iwata Shizuoka 438-8501.Japan  
 Tech. Pub. & Quality Coordination Dept.

# PARTS NEWS



News No. PE0-MC-050086(2/2)

Date: Sep,19,2005

Signature: K.Otsuka

Model	XVS1100A(See the "List of Models and CATALOGUE No's below.")
Subject	PARTS CATALOGUE MODIFICATION
CATALOGUE NO.	See the "List of Models and CATALOGUE No's below."

List of Models and CATALOGUE No's.

The applicable MODELS, MODEL CODES, and CATALOGUE No's. are as follows.

MODEL (MODEL CODE)	CATALOGUE No.	MODEL (MODEL CODE)	CATALOGUE No.
XVS1100AM/XVS1100AMC (5KS1/5KS2)	105KS-110E1	XVS1100A (5KSG)	1A5KS-300E1 2A5KS-300E1
XVS1100AM (5KS3)	105KS-171E1 205KS-171E1	XVS1100A (5KSG)	1A5KS-332G1 2A5KS-332G1
XVS1100A (5KS4)	105KS-300E1 205KS-300E1	XVS1100A (5KSG)	1A5KS-351F1 2A5KS-351F1
XVS1100A (5KS4)	105KS-332G1 205KS-332G1	XVS1100A (5KSG)	1A5KS-352S1 2A5KS-352S1
XVS1100A (5KS4)	105KS-351F1 205KS-351F1	XVS1100AR/XVS1100ARC (5KSR,5KST/5KSS)	1B5KS-100E1 2B5KS-100E1
XVS1100A (5KS4)	105KS-352S1 205KS-352S1		
XVS1100AN/XVS1100ANC (5KS7,5KS9/5KS8)	115KS-100E1 215KS-100E1		
XVS1100A (5KSB)	115KS-300E1 215KS-300E1		
XVS1100A (5KSB)	115KS-332G1 215KS-332G1		
XVS1100A (5KSB)	115KS-351F1 215KS-351F1		
XVS1100A (5KSB)	115KS-352S1 215KS-352S1		

Thank you very much for your cooperation.

Parts  
Manager  
Check

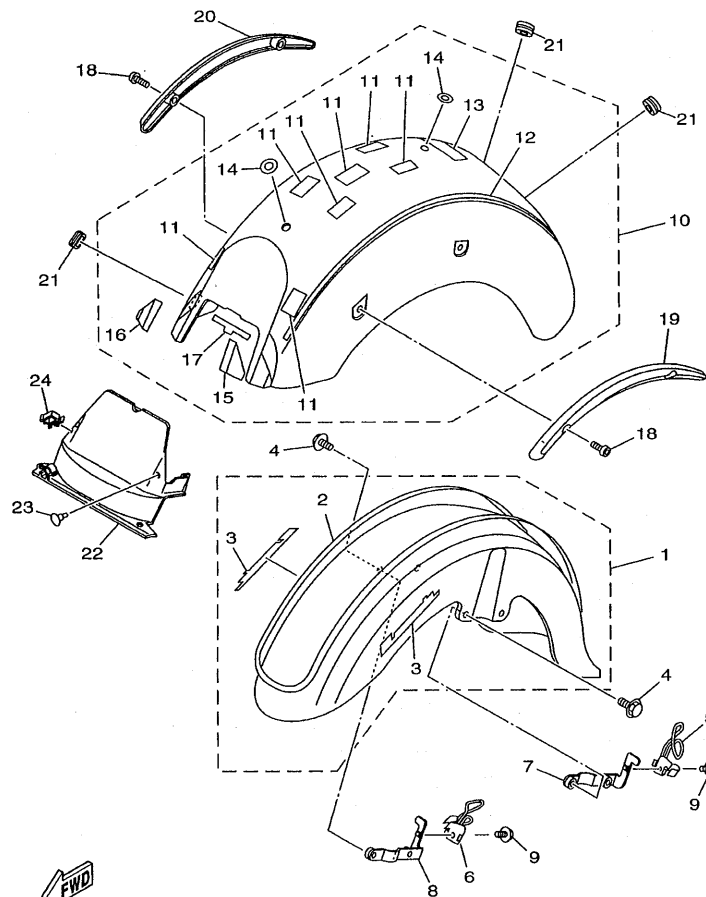
Service  
Manager  
Check

Parts  
Manager  
File

YAMAHA MOTOR CO.,LTD  
2500 Shingai Iwata Shizuoka 438-8501.Japan  
Tech. Pub. & Quality Coordination Dept.



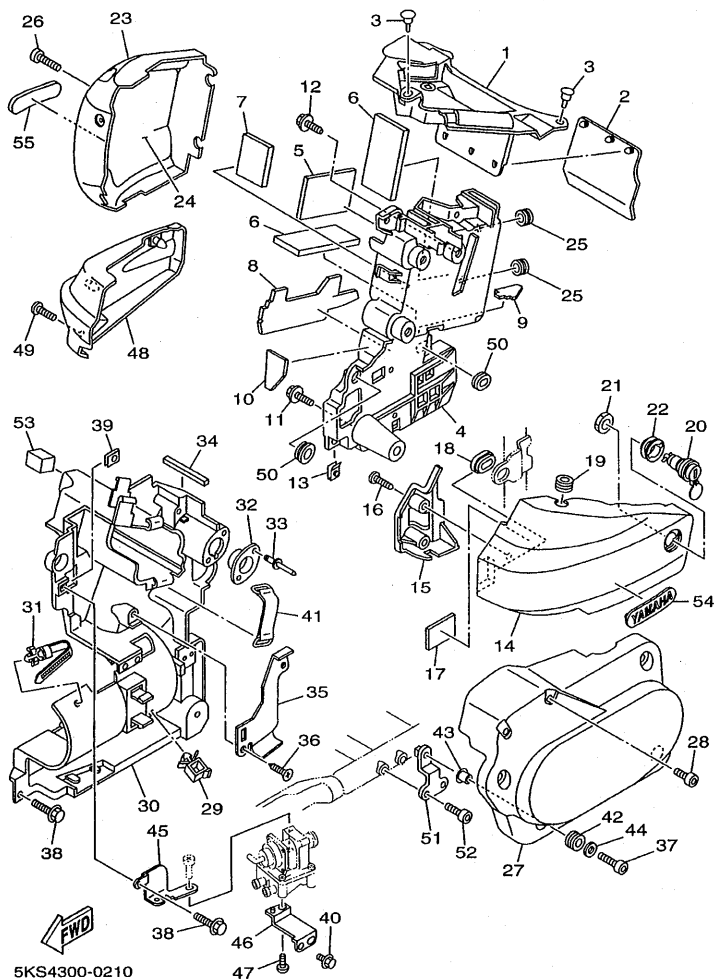
FIG. 20 GUARDABARRO



  
5KS4300-0200

REF. NO.	CODIGO NO.	DESCRIPCION	5K98				OBSERVACION
1	5KS-Y2151-00-33	GUARDABARRO DELANTERO COMPL.	1				UR YB
	5KS-Y2151-70-4X	GUARDABARRO DELANTERO COMPL.	1				UR SM/CRI
2	5KS-21570-00	.CALCOMANIAS GUARDABARRO DEL.	1				UR PARA YB
	5KS-21570-60	.CALCOMANIAS GUARDABARRO DEL.	1				UR PARA SM
3	5BN-21565-00	.EMBLEMA 2	2				
4	95817-08020	TUERCA DE REBORDE	4				
5	5KS-21597-00	SOPORTE DE CABLE 1	1				
6	5KS-21598-00	SOPORTE DE CABLE 2	1				
7	5KS-21587-10	APOYO 1	1				
8	5KS-21588-10	APOYO 2	1				
9	95807-06010	TUERCA DE REBORDE	2				
10	5KS-Y2161-00-33	GUARDABARRO TRASERO COMPLETO	1				UR YB
	5KS-Y2161-70-4X	GUARDABARRO TRASERO COMPLETO	1				UR SM/CRI
11	3SP-21732-00	.SELLO 1	7				
12	5KS-2165A-00	.JUEGO DE EMBLEMA	1				UR PARA YB
	5KS-2165A-60	.JUEGO DE EMBLEMA	1				UR PARA SM
13	99247-00080	.EMBLEMA, YAMAHA	1				
14	4NK-21735-00	.SELLO 2	2				
15	5KS-21669-00	.SELLO	1				
16	5KS-21669-10	.SELLO	1				
17	5KS-21669-20	.SELLO	1				
18	92014-08025	PERNO	4				
19	4WM-2164F-00	APOYO 1	1				
20	4WM-2164G-00	APOYO 2	1				
21	90480-15061	TAPON	3				
22	5KS-21629-00	GUARDABARRO INFERIOR	1				
23	90269-07077	REMACHE	2				



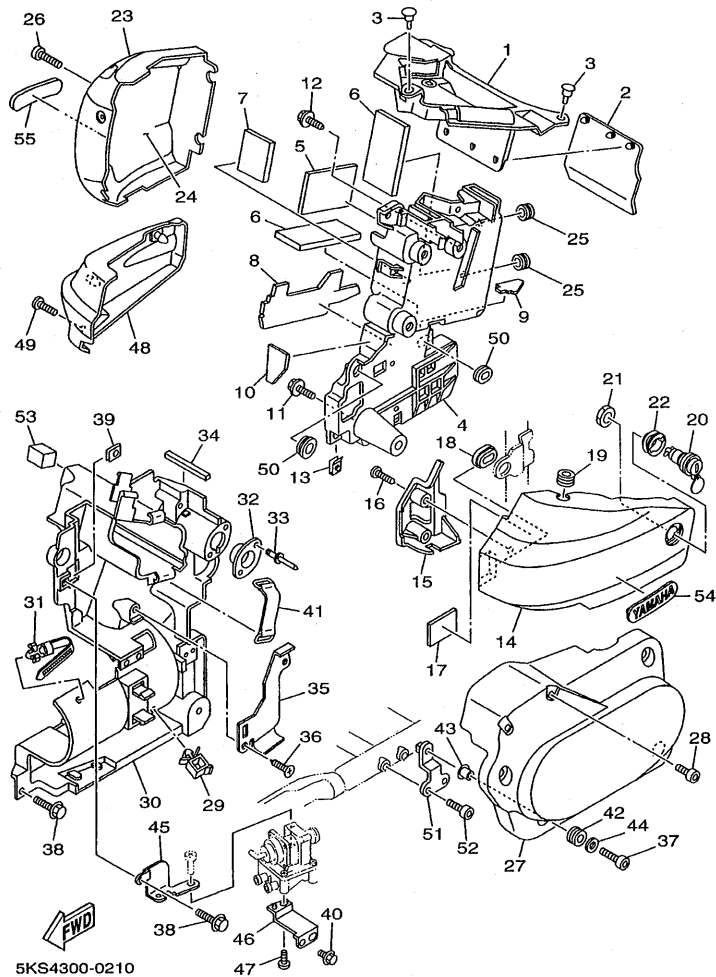


5KS4300-0210

FIG. 21 CUBIERTA LATERAL

REF. NO.	CODIGO NO.	DESCRIPCION	5KSB				OBSERVACION
1	5EL-2177J-00	TAPA 2	1				
2	30X-21621-00	CHARNELA	1				
3	90269-07077	REMACHE	3				
4	5EL-2177G-00	CAJA DE BATERIA	1				
5	29N-14425-00	AMORTIGUADOR 1	1				
6	5Y1-82122-00	ASIENTO DE BATERIA	2				
7	M12-T133A-00	ASIENTO DE AMORTIGUADOR A	1				
8	5EL-2172A-00	PANEL	1				
9	5EL-2172F-00	PANEL 2	1				
10	5EL-2172G-00	PANEL 2	1				
11	90119-06096	TORNILLO CON ARANDELA	5				
12	90119-06060	TORNILLO CON ARANDELA	1				
13	90183-06053	TUERCA DE RESORTE	2				
14	5KS-21711-00-33	TAPA LATERAL 1	1				UR YB
	5KS-21711-00-MX	TAPA LATERAL 1	1				UR SM
15	5EL-2171Y-00	CUBIERTA LATERAL COMPLETA 1	1				
16	97707-50014	TORNILLO ROSCA HEMBRA	2				
17	3YL-12232-00	AMORTIGUADOR	1				
18	90480-01558	TAPON	1				
19	90480-12550	TAPON	1				
20	55K-21708-00	CUBIERTA 2	1				
21	90170-22187	TUERCA	1				
22	90480-24186	TAPON	1				
23	5KS-21721-00-33	TAPA LATERAL 2	1				UR YB
	5KS-21721-00-MX	TAPA LATERAL 2	1				UR SM
24	5KS-2172A-00	PANEL	1				
25	90480-12320	TAPON	2				

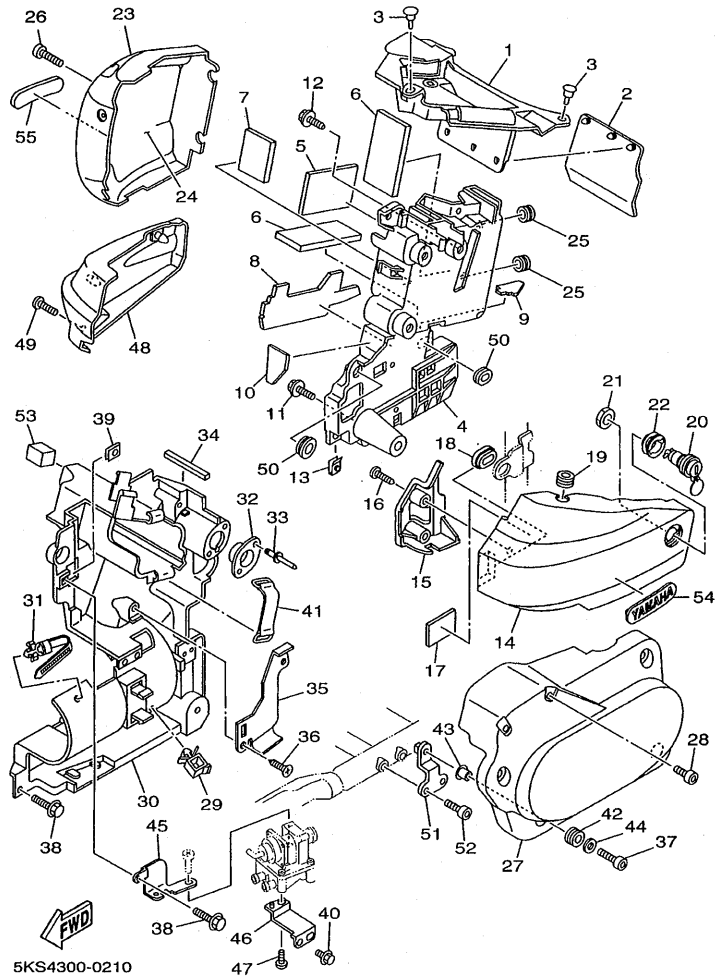
FIG. 21 CUBIERTA LATERAL



5KS4300-0210

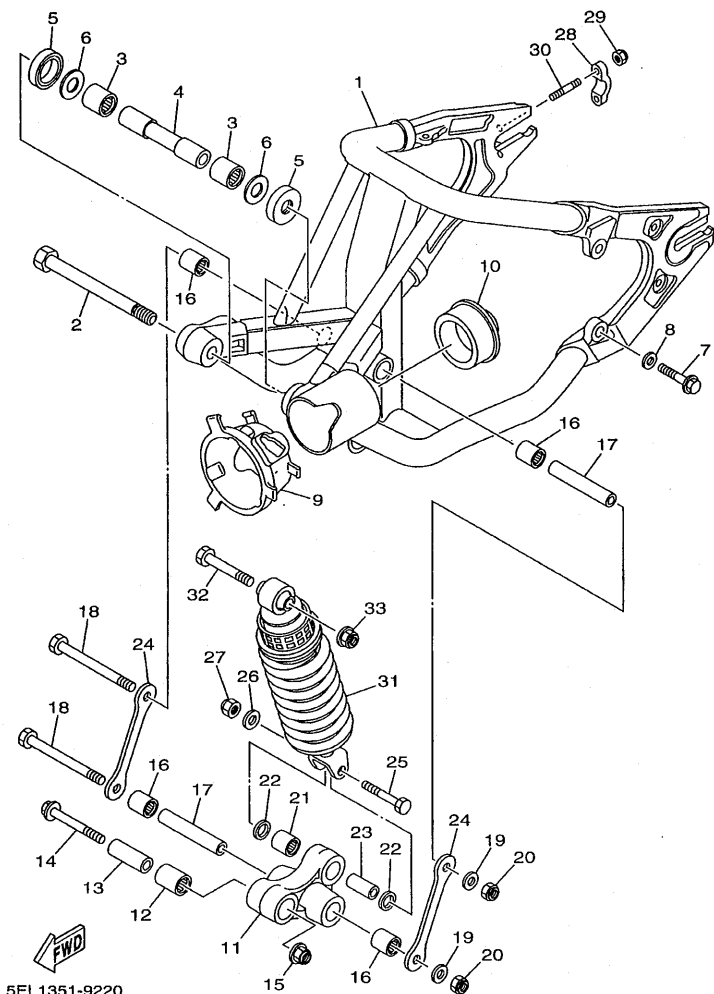
REF. NO.	CODIGO NO.	DESCRIPCION	5KSB				OBSERVACION
26	90149-06302	TORNILLO DE REGLAJE	1				
27	5EL-21731-00	TAPA LATERAL 3	1				
28	90110-06254	TORNILLO ALLEN	2				
29	90464-16025	BRIDA	1				
30	5EL-2177E-00	TAPA	1				
31	90464-12089	BRIDA	1				
32	4TR-2175H-00	SOPORTE DE CERRADURA	1				
33	90267-40180	REMACHE CIEGO	2				
34	1FK-83526-00	AMORTIGUADOR 2	1				
35	5EL-2178L-00	GUIA 1	1				
36	97707-60016	TORNILLO ROSCA HEMBRA	2				
37	91314-06025	PERNO	4				
38	90119-06096	TORNILLO CON ARANDELA	3				
39	90183-06053	TUERCA DE RESORTE	4				
40	95807-06010	TUERCA DE REBORDE	3				
41	3TJ-82131-00	TIRANTE DE BATERIA	1				
42	90480-10289	TAPON	4				
43	90387-066Y6	CASQUILLO CON VALONA	4				
44	90201-06062	ARANDELA PLANA	4				
45	5EL-2172K-00	SOSTEN	1				
46	5EL-2172L-00	SOSTEN	1				
47	92017-06012	PERNO	1				
48	5EL-21741-00	CUBIERTA LATERAL 4	1				
49	90149-06302	TORNILLO DE REGLAJE	1				
50	90480-01558	TAPON	2				
51	5EL-2172M-00	SOPORTE 3	1				
52	91317-06020	PERNO	2				

FIG. 21 CUBIERTA LATERAL



REF. NO.	CODIGO NO.	DESCRIPCION	5KSB				OBSERVACION
53	5EL-21746-00	AMORTIGUADOR	1				
54	3LS-21781-10	EMBLEMA 1	1				
55	3LS-21781-10	EMBLEMA 1	1				



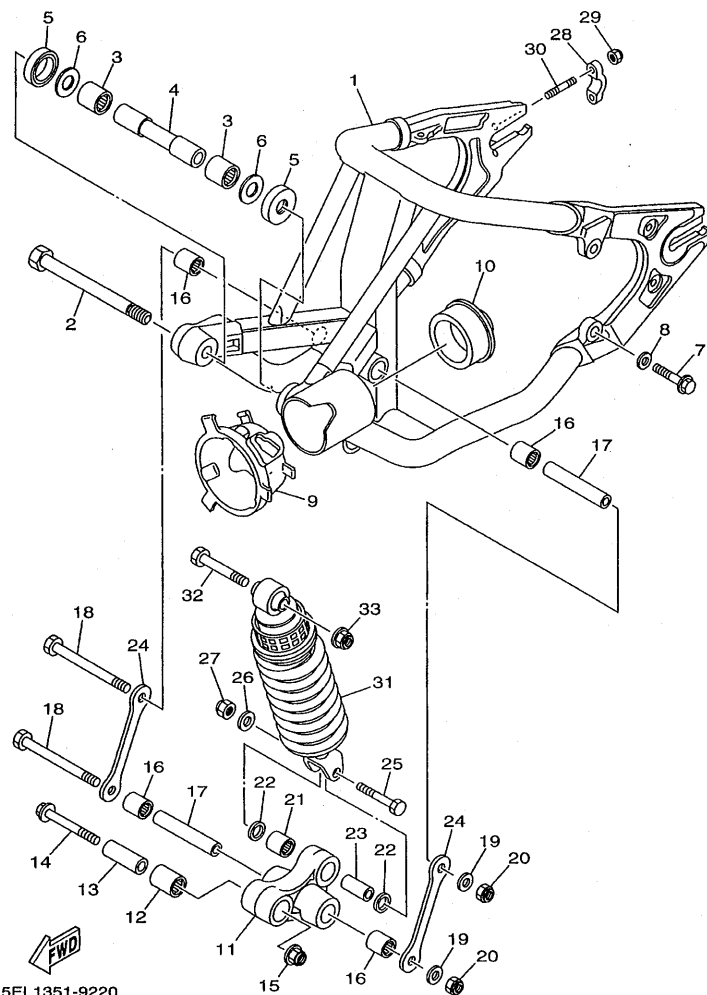


5EL1351-9220

FIG. 22 BRAZO TRASERO. SUSPENSION

REF. NO.	CODIGO NO.	DESCRIPCION	5K/5B				OBSERVACION
1	5KS-22110-00	BRAZO TRASERO COMPLETO	1				
2	5EL-22141-00	EJE DEL BARCULANTE	1				
3	93320-32403	COJINETE	2				
4	4X7-22124-00	BUJE 2	1				
5	5EL-22129-00	TAPA DE EMPUJE 2	2				
6	90201-243U9	ARANDELA PLANA	2				
7	90105-101A9	TORNILLO CON ARANDELA	4				
8	90201-112U0	ARANDELA PLANA	4				
9	5EL-22189-00	FUNDA DE GOMA	1				
10	4VR-22184-00	BUJE	1				
11	4KM-2217A-00	BRAZO REEURIO	1				
12	93317-42060	COJINETE	1				
13	90387-100T8	CASQUILLO CON VALONA	1				
14	90105-10727	TORNILLO CON ARANDELA	1				
15	95607-10200	TUERCA DE AUTO-CIERRE	1				
16	93317-41761	COJINETE	4				
17	90387-126T1	CASQUILLO CON VALONA	2				
18	90101-12673	TORNILLO	2				
19	90201-126A7	ARANDELA PLANA	2				
20	95617-12100	PERNO DE PUNTAL	2				
21	93317-31771	COJINETE	1				
22	93109-17071	SELLO ACEITE	2				
23	90387-127W0	CASQUILLO CON VALONA	1				
24	2KT-2217M-00	BRAZO 1	2				
25	90101-10659	TORNILLO	1				
26	90201-101J1	ARANDELA PLANA	1				
27	95617-10100	PERNO DE PUNTAL	1				

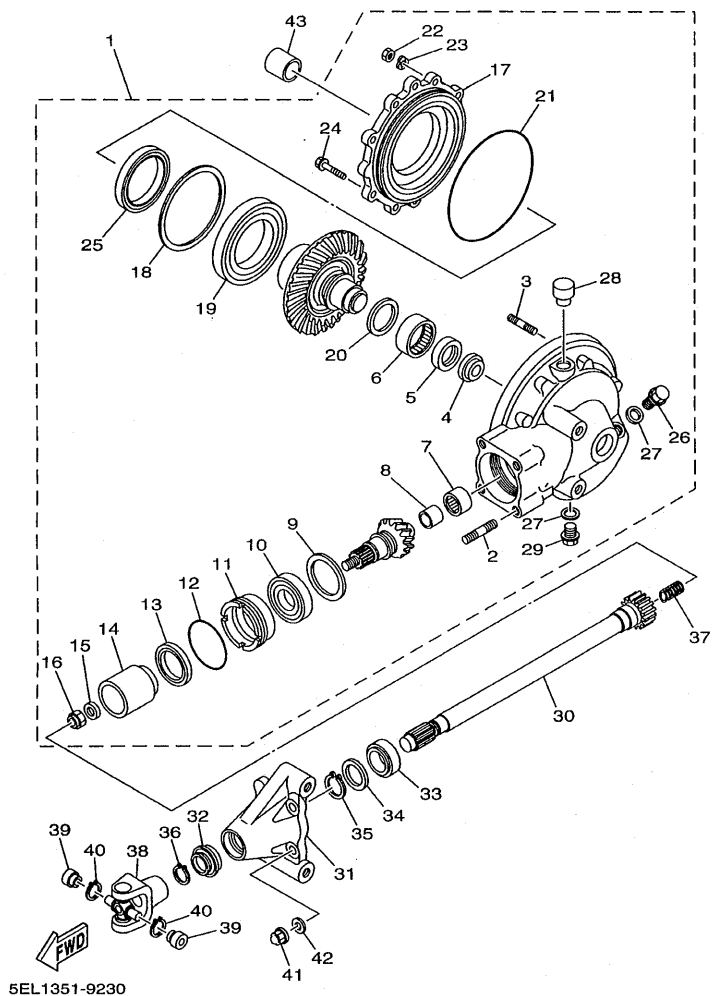
FIG. 22 BRAZO TRASERO. SUSPENSION



5EL1351-9220

REF. NO.	CODIGO NO.	DESCRIPCION	5KSB				OBSERVACION
28	1E6-23441-10-98	SOPORTE DE MANUBRIO	1				LGB
29	95607-08200	TUERCA DE AUTO-CIERRE	2				
30	95627-08330	PERNO DE PUNTAL	2				
31	5KS-22210-01	AMORTIGUADOR TRASERO COMPLETO	1				
32	90109-10554	PERNO	1				
33	95607-10200	TUERCA DE AUTO-CIERRE	1				
-----							
-----							
-----							
-----							
-----							

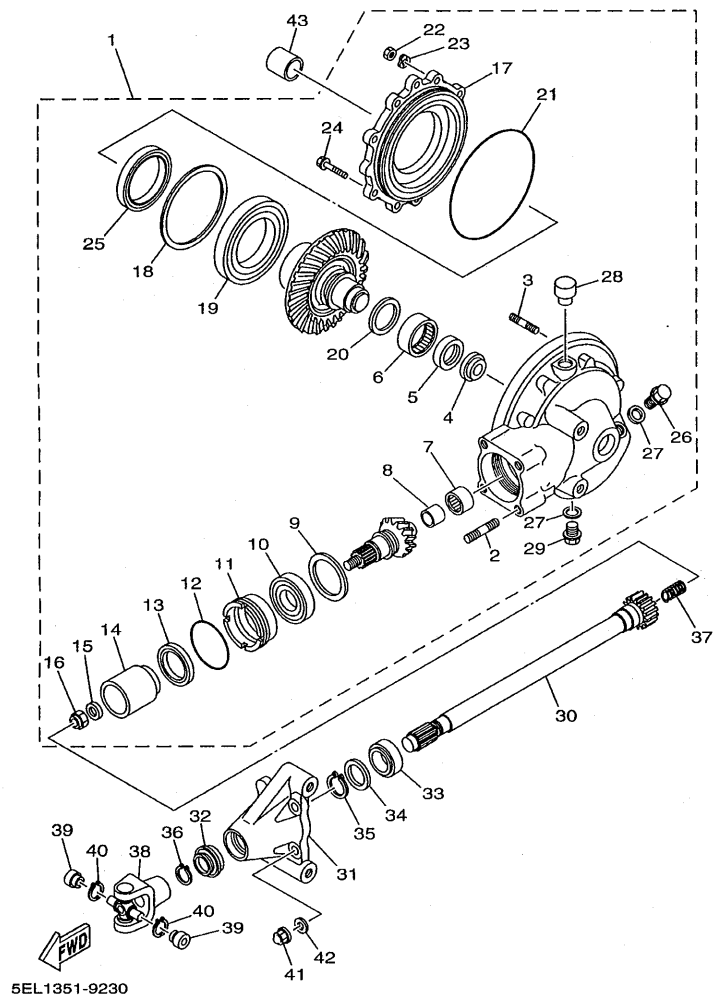
FIG. 23 EJE DE TRACCION



5EL1351-9230

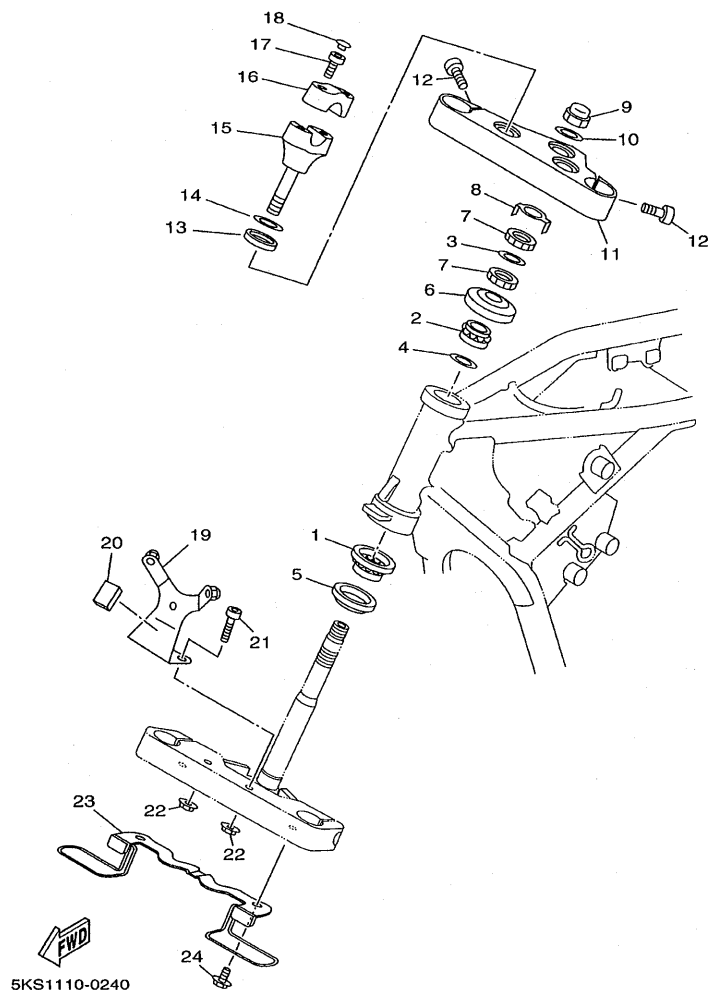
REF. NO.	CODIGO NO.	DESCRIPCION	5K5B				OBSERVACION
1	5EL-46101-00	CAJA ENGRANAJE EJE TRAS COMPL	1				
2	90116-10593	.ESPARRAGO	4				
3	90116-08360	.ESPARRAGO	6				
4	5EL-46153-00	.COLLAR DE GUIA	1				
5	93101-30084	.SELLO ACEITE	1				
6	93311-43729	.COJINETE	1				
7	93317-41510	.COJINETE	1				
8	2H7-46122-00	.CARRERA INTERIOR	1				
9	1J7-17537-Y0-30	.CUNA DE EMPUJE (0.30T)	1				UR
	1J7-17537-Y0-40	.CUNA DE EMPUJE (0.40T)	1				UR
	1J7-17537-Y0-50	.CUNA DE EMPUJE (0.50T)	1				UR
10	93306-30533	.COJINETE (B6305RB1)	1				
11	4H7-46125-00	.RETEN DE COJINETE	1				
12	93210-60426	.ANILLO O	1				
13	93101-38098	.SELLO ACEITE	1				
14	4H7-46123-01	.ACOPLAMIENTO DE ENGRANAJE	1				
15	90201-14632	.ARANDELA PLANA	1				
16	90185-14070	.TUERCA AUTOBLOCANTE	1				
17	4H7-46152-00	.CAJA DE COJINETE	1				
18	1J7-46117-Y0-25	.CUNA ENGRANAJE DE ANILLO	1				UR
	1J7-46117-Y0-30	.CUNA ENGRANAJE DE ANILLO (0.3T)	1				UR
	1J7-46117-Y0-40	.CUNA ENGRANAJE DE ANILLO (0.4T)	1				UR
	1J7-46117-Y0-50	.CUNA ENGRANAJE DE ANILLO (0.5T)	1				UR
19	93316-01403	.COJINETE	1				
20	22U-46118-00-12	.ARANDELA DE EMPUJE (1.2T)	1				UR
	22U-46118-00-14	.ARANDELA DE EMPUJE (1.4T)	1				UR
	22U-46118-00-16	.ARANDELA DE EMPUJE (1.6T)	1				UR

FIG. 23 EJE DE TRACCION



REF. NO.	CODIGO NO.	DESCRIPCION	5KSB			OBSERVACION
20	22U-46118-00-18	.ARANDELA DE EMPUJE (1.8T)	1			UR
	22U-46118-00-20	.ARANDELA DE EMPUJE (2.0T)	1			UR
21	93211-44348	.ANILLO O	1			
22	95317-08600	.TUERCA	6			
23	92907-08700	.ARANDELA	6			
24	95827-10025	.TUERCA DE REBORDE	2			
25	93102-70167	.SELLO ACEITE	1			
26	90340-14132	.TORNILLO, DE DRENAJE	1			
27	214-11198-01	.EMPAQUE	2			
28	56W-17590-00	.RESPIRADERO COMPLETO	1			
29	90340-14135	.TORNILLO, DE DRENAJE	1			
30	5EL-46171-00	EJE DE TRACCION COMPL.	1			
31	5EL-46154-00	CUBIERTA DE ENCAJE	1			
32	5EL-46297-00	CUBIERTA, PARA POLOVO	1			
33	93108-43014	SELLO ACEITE	1			
34	90201-266L1	ARANDELA PLANA	1			
35	93410-26067	BOLA	1			
36	93410-22039	BOLA	1			
37	90501-16491	RESORTE DE COMPRESION	1			
38	4X7-46180-00	JUNTA TRASVERSAL COMPLETA	1			
39	93311-21044	COJINETE	2			
40	93440-20088	BOLA	2			
41	90176-10075	TUERCA CORONA	4			
42	92990-10600	ARANDELA	4			
43	90387-172A5	CASQUILLO CON VALONA	1			

FIG. 24 DIRECCION



5KS1110-0240

REF. NO.	CODIGO NO.	DESCRIPCION	5KSB				OBSERVACION
1	93399-99932	COJINETE	1				
2	93399-99931	COJINETE	1				
3	90202-26142	ARANDELA DE PLANA	1				
4	90202-24190	ARANDELA DE PLANA	1				
5	3FV-23462-00	RETEN DE DIRECCION	1				
6	1W1-23416-00	CUBIERTA DE BASE DE BOLA 2	1				
7	90179-25033	TUERCA	2				
8	26H-23418-01	ARANDELA ESPECIAL	1				
9	90176-22081	TUERCA CORONA	1				
10	90201-220T0	ARANDELA PLANA	1				
11	4VR-W2341-20	FIJADOR DE MANIJA	1				
12	91314-08030	PERNO	2				
13	3DM-23445-00	AMORTIGUADOR	2				
14	90201-14220	ARANDELA PLANA	2				
15	4VR-23442-00	SOPORTE DE MANUBRIO INFERIOR	2				
16	4VR-23441-00	SOPORTE DE MANUBRIO	2				
17	91314-08025	PERNO	4				
18	90338-08163	TAPON	4				
19	5BN-23174-00	SOPORTE DEL FARO DELANTERO	1				
20	5BN-2317J-00	AMORTIGUADOR 1	1				
21	92014-08040	PERÑO	2				
22	95707-08500	TUERCA DE BRIDA	2				
23	5KS-25886-00	SOPORTE DE MANGUERA FRENO	1				
24	95024-06010	PERNO, DE BRIDA	2				

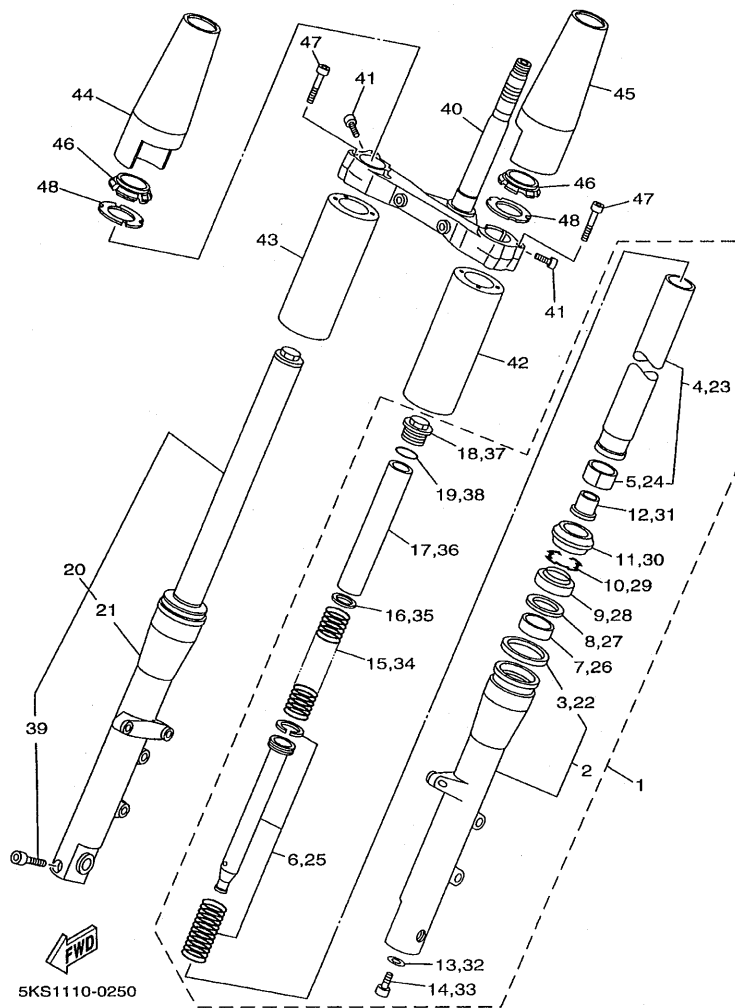


FIG. 25 HORQUILLA DELANTERA

REF. NO.	CODIGO NO.	DESCRIPCION	5K/5B				OBSERVACION
1	5KS-23102-00	HORQUILLA DELANTERA COMPL. (MI)	1				
2	5KS-23126-00	.TUBO EXTERIOR 1	1				
3	5BN-23193-00	..GUIA DE FUNDA	1				
4	5KS-23110-00	.TUBO INTERIOR COMPLETO 1	1				
5	5BN-23171-00	..PISTON HORQUILLA DELANT.	1				
6	5EL-23170-00	..CILINDRO COMPL DE HORQ DELAN	1				
7	4FM-23125-40	.METAL CORREDIZO 1	1				
8	36Y-23146-10	.ARANDELA DE SELLO DE ACEITE	1				
9	4EB-23145-00	.RETEN DE ACEITE	1				
10	26H-23156-00	.PRESILLA DEL RETEN DE ACEITE	1				
11	4EB-23144-00	.GUARDAPOLVO	1				
12	4YR-23173-00	.VASTAGO AHUSADO	1				
13	509-23158-L0	.EMPAQUE	1				
14	278-23181-50	.TORNILLO CABEZAHEXAGONAL	1				
15	5KS-23141-00	.RESORTE HORQUILLA DELANT.	1				
16	4DW-23149-40	.ARANDELA DE RESORTE SUPERIOR	1				
17	5EL-23118-00	.SEPARADOR	1				
18	3EN-23111-50	.TAPON	1				
19	43F-23188-10	.ANILLO O	1				
20	5KS-23103-00	HORQUILLA DELANTERA COMPL. (MD)	1				
21	5KS-23136-00	.TUBO EXTERIOR (DER.)	1				
22	5BN-23193-00	..GUIA DE FUNDA	1				
23	5KS-23110-00	.TUBO INTERIOR COMPLETO 1	1				
24	5BN-23171-00	..PISTON HORQUILLA DELANT.	1				
25	5EL-23170-00	..CILINDRO COMPL DE HORQ DELAN	1				
26	4FM-23125-40	.METAL CORREDIZO 1	1				
27	36Y-23146-10	.ARANDELA DE SELLO DE ACEITE	1				

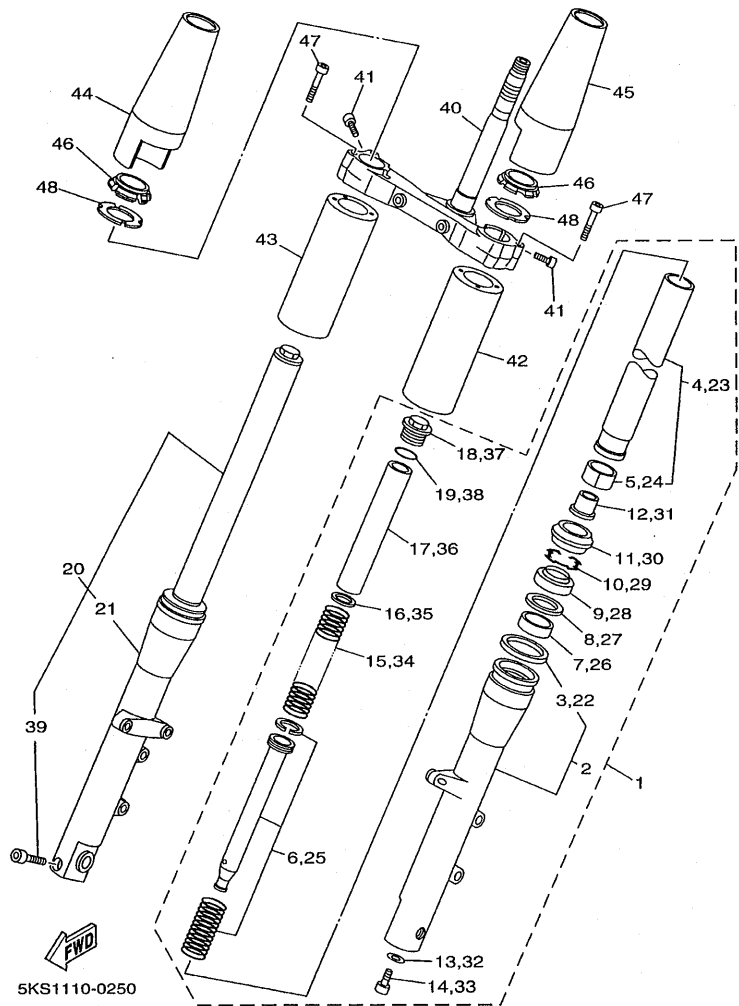
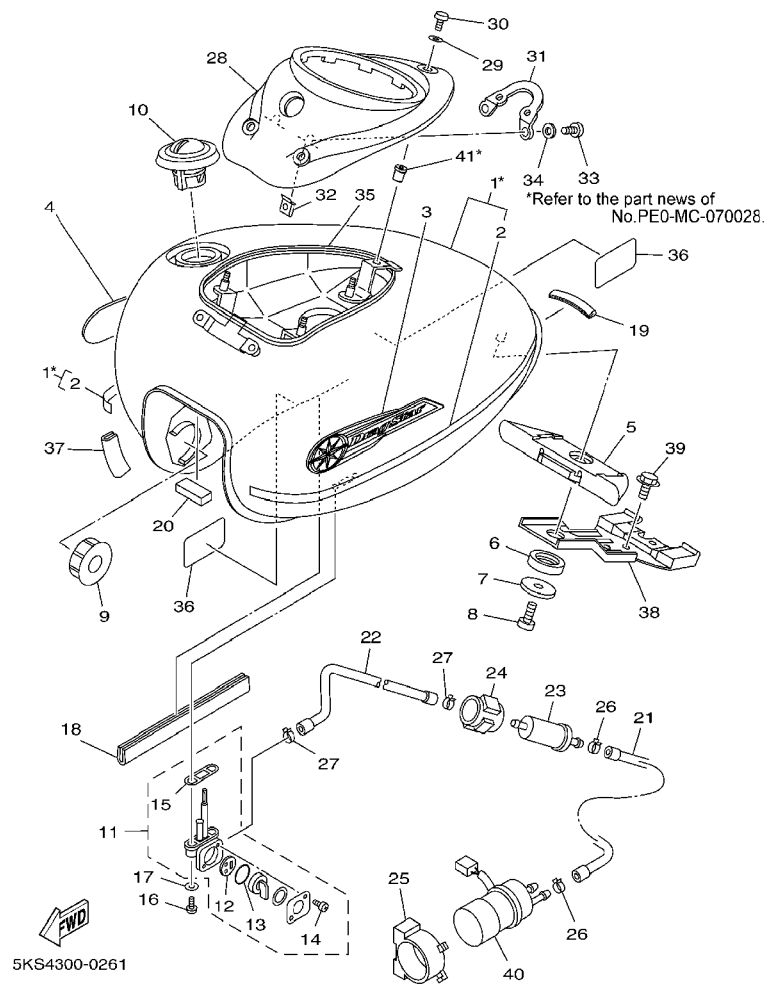


FIG. 25 HORQUILLA DELANTERA

REF. NO.	CODIGO NO.	DESCRIPCION	5KSB				OBSERVACION
28	4EB-23145-00	.RETEN DE ACEITE	1				
29	26H-23156-00	.PRESILLA DEL RETEN DE ACEITE	1				
30	4EB-23144-00	.GUARDAPOLVO	1				
31	4YR-23173-00	.VASTAGO AHUSADO	1				
32	509-23158-L0	.EMPAQUE	1				
33	278-23181-50	.TORNILLO CABEZAHEXAGONAL	1				
34	5KS-23141-00	.RESORTE HORQUILLA DELANT.	1				
35	4DW-23149-40	.ARANDELA DE RESORTE SUPERIOR	1				
36	5EL-23118-00	.SEPARADOR	1				
37	3EN-23111-50	.TAPON	1				
38	43F-23188-10	.ANILLO O	1				
39	91314-08040	.PERNO	1				
40	5KS-23340-00	PLATINA INFERIOR COMPLETA	1				
41	91314-08020	PERNO	4				
42	5KS-23123-00	CUBIERTA INFERIOR 1	1				
43	5KS-23133-00	CUBIERTA INFERIOR 2	1				
44	5BN-23131-00	CUBIERTA SUPERIOR 2	1				
45	5BN-23121-00	CUBIERTA SUPERIOR 1	1				
46	5BN-23163-00	EMPAQUE	2				
47	5BN-23394-00	PERNO ESPECIAL	6				
48	5BN-23165-00	ARANDELA DE FIELTRO	2				

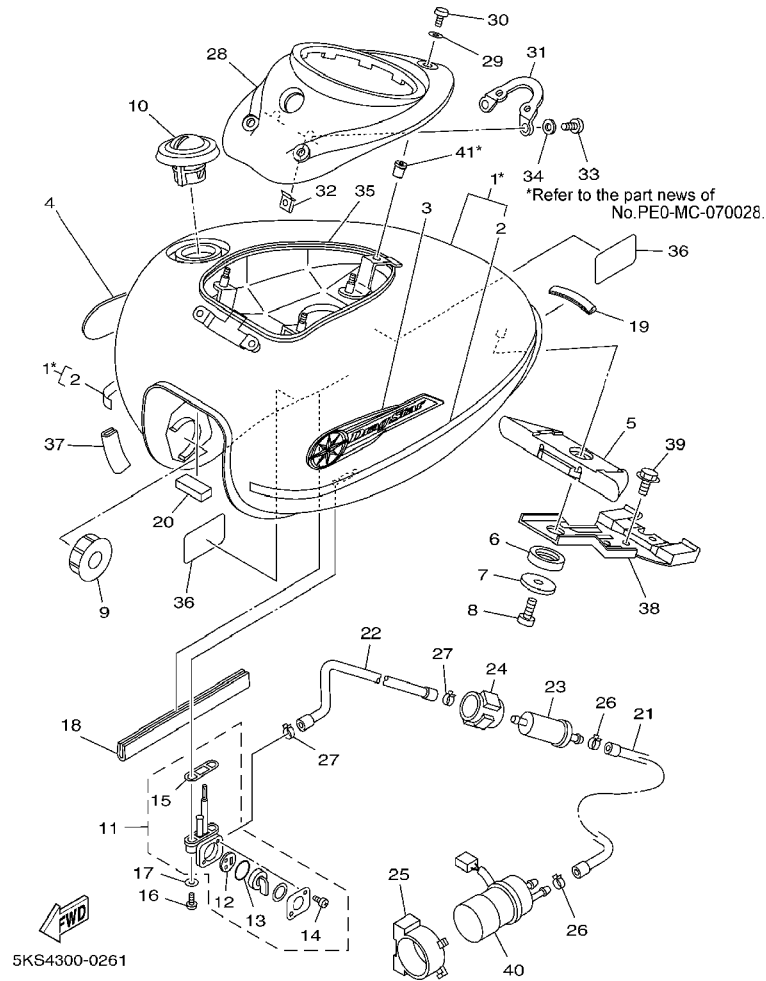
FIG. 26 DEPOSITO DE COMBUSTIBLE



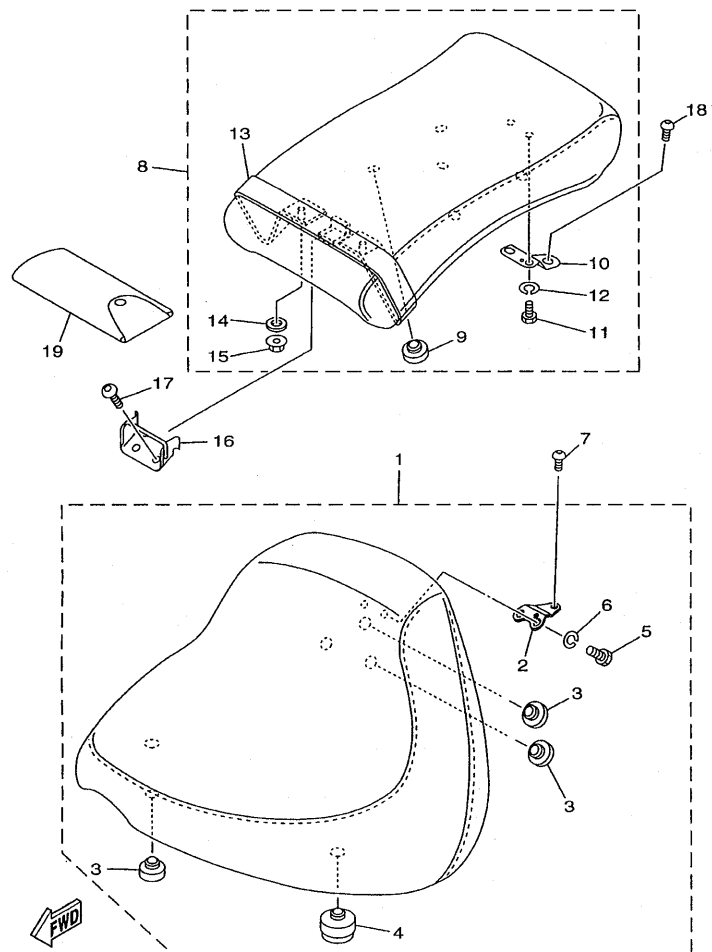
REF. NO.	CODIGO NO.	DESCRIPCION	5KSB		OBSERVACION
1	5EL-Y2410-12-W4	DEPOSITO DE COMBUSTIBLE COMP.	1		UR YB
	5EL-Y2410-12-X8	DEPOSITO DE COMBUSTIBLE COMP.	1		UR SM/CRI
2	5KS-24240-20	JUEGO DE CALCOMANIAS	1		UR PARA YB
	5KS-24240-60	JUEGO DE CALCOMANIAS	1		UR PARA SM
3	4VR-24161-01	EMBLEMA 1	1		
4	4VR-24162-01	EMBLEMA 2	1		
5	5EL-24182-00	AMORTIGUADOR DE MONTAJE 2	1		
6	4TR-24183-00	AMORTIGUADOR DE MONTAJE 3	1		
7	90201-060S9	ARANDELA PLANA	1		
8	92017-06012	PERNO	1		
9	2YK-24181-10	AMORTIGUADOR DE MONTAJE	2		
10	5BN-24602-00	TAPON COMPLETO	1		
11	4WM-24500-00	GRIFO DE COMBUSTIBLE 1	1		
12	3AJ-24523-00	.VALVULA	1		
13	3AJ-24534-00	.SELLO DE GRIFO	1		
14	97801-03008	.TORNILLO	2		
15	4X8-24512-00	.EMPAQUE	1		
16	90149-06011	TORNILLO DE REGLAJE	2		
17	90202-05193	ARANDELA DE PLANA	2		
18	1FK-2171L-00	MUELLE , CUBIERTA LATERAL 1	1		
19	5EL-24188-00	MOLDURA DEPOSITO COMBUST.	1		
20	3XV-21717-00	AMORTIGUADOR	1		
21	5EL-24311-00	TUBO DE COMBUSTIBLE 1	1		
22	5EL-24313-00	TUBO 3	1		
23	1FK-24560-00	FILTRO COMPLETO	1		
24	1FK-24566-00	SOPORTE DEL FILTRO	1		
25	4EB-24398-00	BANDA 1	1		



FIG. 26 DEPOSITO DE COMBUSTIBLE



REF. NO.	CODIGO NO.	DESCRIPCION	5KSB			OBSERVACION
26	90467-12053	PRESILLA	2			
27	90467-11028	PRESILLA	2			
28	5EL-2171A-00	CUBIERTA, TECHO	1			
29	90202-05180	ARANDELA DE PLANA	3			
30	90110-05201	TORNILLO ALLEN	3			
31	5EL-2412F-00	SOPORTE ASIENTO	1			
32	90183-05061	TUERCA DE RESORTE	2			
33	98507-05012	TORNILLO DE CABEZA CON PLANA	2			
34	92907-05800	ARANDELA	2			
35	5EL-2414G-00	SELLO	2			
36	4DN-21268-00	SELLO	2			
37	5EL-24188-00	MOLDURA DEPOSITO COMBUST.	1			
38	5EL-2411F-00	PLACA, ADITAMENTO 2	1			
39	95807-08012	TUERCA DE REBORDE	2			
40	3LN-13907-00	BOMBA DE COMBUSTIBLE COMPLETA	1			
41	90179-05009	TUERCA	3			



5KS1110-0270

FIG. 27 ASIENTO

REF. NO.	CODIGO NO.	DESCRIPCION	BK/SB				OBSERVACION
1	5KS-24710-00	ASIENTO SIMPLE COMPLETO	1				
2	5KS-2475H-00	.SOPORTE PALANCA ASIENTO 1	1				
3	22W-24741-00	.COJIN DE ASIENTO	4				
4	1T4-24741-00	.COJIN DE ASIENTO	2				
5	97007-06012	.PERNO	2				
6	92907-06100	.ARANDELA	2				
7	92014-08012	PERNO	1				
8	5KS-24750-00	ASIENTO TANDEM COMPLETO	1				Go to P/N: PE0-MC-050086
9	22W-24741-00	.COJIN DE ASIENTO	5				
10	5BN-2475J-00	.SOPORTE PALANCA ASIENTO 2	1				Go to P/N: PE0-MC-050086
11	97007-06012	.PERNO	2				
12	92907-06100	.ARANDELA	2				
13	5KS-24734-00	.BANDA DE ASIENTO	1				
14	90207-06380	.ARANDELA DE TERMINACION	2				
15	95707-06500	.TUERCA DE BRIDA	2				
16	5KS-2475N-00	SOPORTE	1				
17	92017-06016	PERNO	2				
18	92014-08012	PERNO	1				Go to P/N: PE0-MC-050086
19	5EL-28100-10	JUEGO DE HERRAMIENTAS	1				

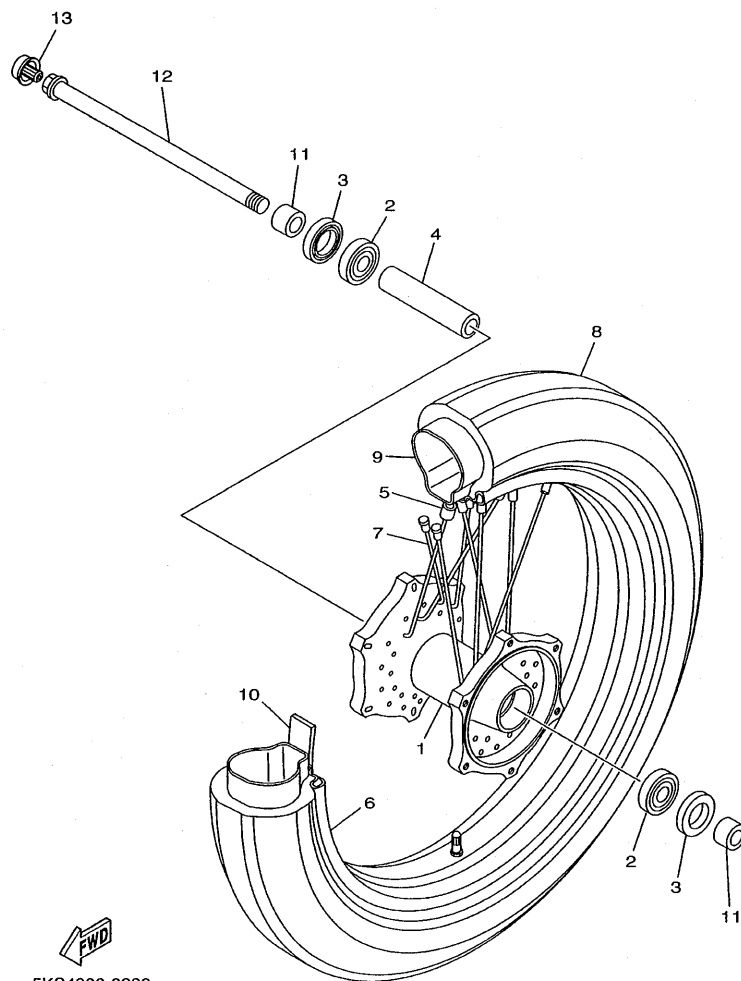
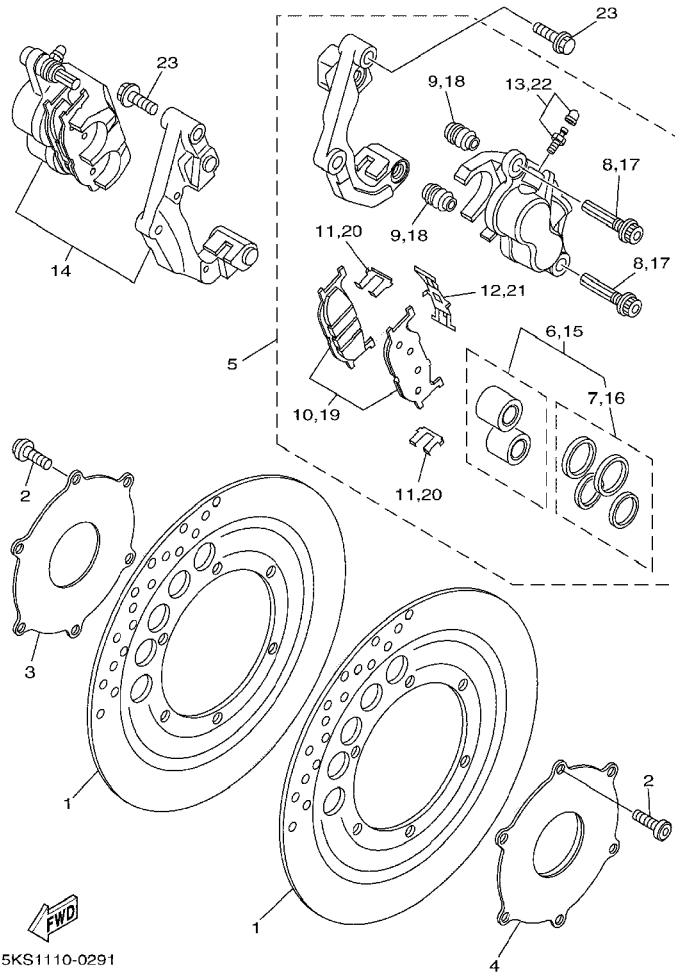


FIG. 28 RUEDA DELANTERA

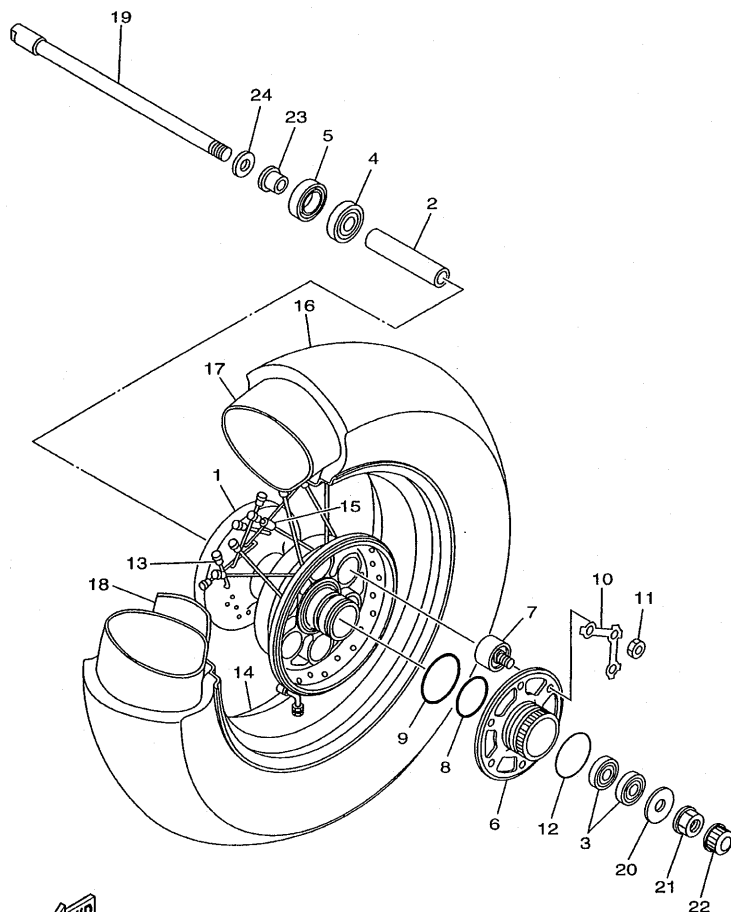
REF. NO.	CODIGO NO.	DESCRIPCION	5KSB				OBSERVACION
1	5EL-25111-00	MASA DELANTERA	1				
2	93306-30317	COJINETE	2				
3	93102-28022	SELLO ACEITE	2				
4	90387-173M5	CASQUILLO CON VALONA	1				
5	5V4-25398-00	CONTRAPESO DE RUEDA	1				UN
6	94430-16565	ARO	1				
7	5KS-25104-00	JUEGO DE RAYOS DELANTERO	1				
8	94113-1613E	NEUMATICO (130/90-16 67S D404F)	1				DUNLOP
9	94213-16305	TUBO (130/90-16 TR4)	1				DUNLOP
10	94313-16175	BANDA DE ARO	1				DUNLOP
11	90387-173R6	CASQUILLO CON VALONA	2				
12	5KS-25181-00	EJE DE LA RUEDA	1				
13	5KS-25188-00	TAPA	1				

FWD  
5KS4300-0280

FIG. 29 CALIBRE FRENO DELANTERA



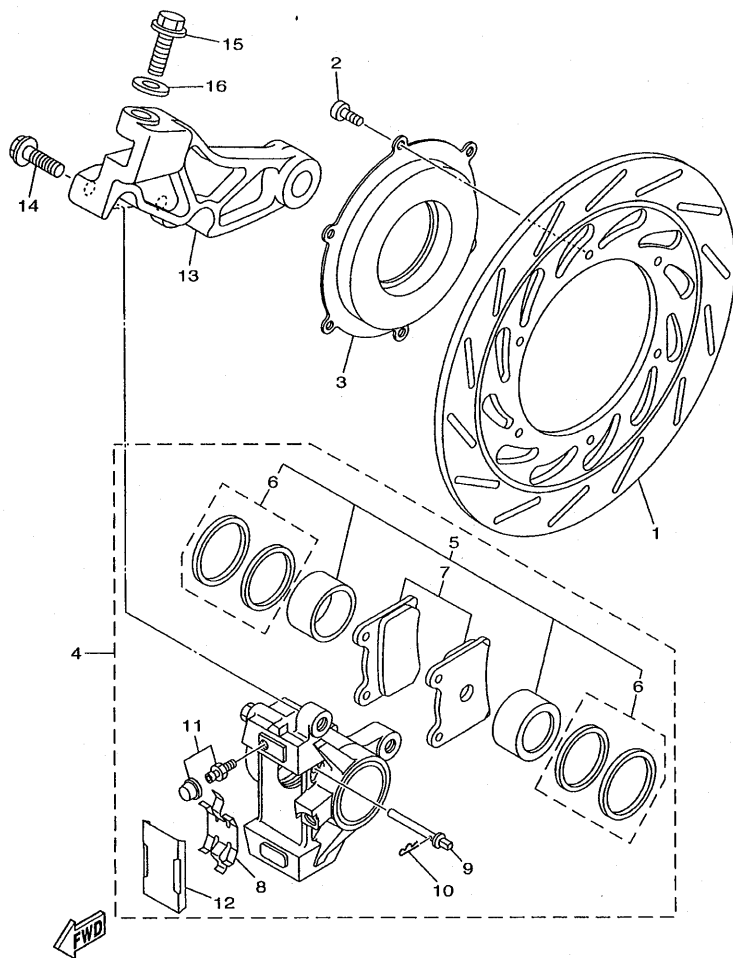
REF. NO.	CODIGO NO.	DESCRIPCION	5KSB			OBSERVACION
1	3JB-2582U-01	DISCO DE FRENO (DERECO)	2			
2	90109-08006	PERNO	12			
3	5EL-2514A-00	AROS, MASA 1 (D)	1			
4	5KS-2515A-00	AROS, MASA 2 (I)	1			
5	5KS-2580T-00	CALIBRE COMPLETO (IZQUIERDO)	1			
6	5KS-W0057-00	.PISTON COMPLETO PINZA	1			
7	4FU-W0047-00	..JUEGO DE RETENES DE PINZA	1			
8	4TT-25914-00	.PASADOR	2			
9	4TT-25937-00	.FUNDA	2			
10	4EB-W0045-00	.JUEGO DE COJIN DE FRENO	1			
11	4BP-25919-00	.SOPORTE DE PASTILLAS	2			
12	3YX-25929-00	.RESORTE PLACA, COJIN DE FRENO	1			
13	51L-W0048-00	.CJTO TORNILLO DE PURGA	1			
14	5KS-2580U-00	CALIBRE COMPLETO (DERECO)	1			
15	5KS-W0057-00	.PISTON COMPLETO PINZA	1			
16	4FU-W0047-00	..JUEGO DE RETENES DE PINZA	1			
17	4TT-25914-00	.PASADOR	2			
18	4TT-25937-00	.FUNDA	2			
19	4EB-W0045-00	.JUEGO DE COJIN DE FRENO	1			
20	4BP-25919-00	.SOPORTE DE PASTILLAS	2			
21	3YX-25929-00	.RESORTE PLACA, COJIN DE FRENO	1			
22	51L-W0048-00	.CJTO TORNILLO DE PURGA	1			
23	90105-10638	TORNILLO CON ARANDELA	4			



5KS4300-0300

FIG. 30 RUEDA TRASERA

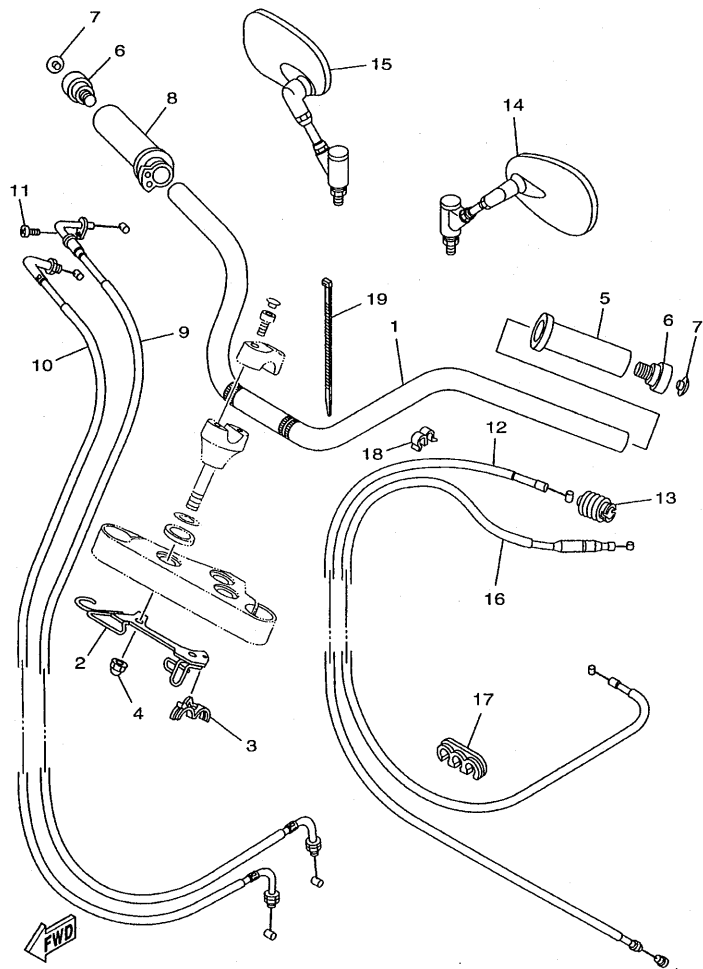
REF. NO.	CODIGO NO.	DESCRIPCION	5KSB				OBSERVACION
1	5EL-25311-00	MASA TRASERA	1				
2	90387-173M5	CASQUILLO CON VALONA	1				
3	93306-20348	COJINETE	2				
4	93306-30317	COJINETE	1				
5	93102-25044	SELLO ACEITE	1				
6	16G-25366-01	EMBRAGUE DE MASA	1				
7	5EL-25364-00	AMORTIGUADOR	6				
8	93210-48530	ANILLO O	1				
9	93210-59531	ANILLO O	1				
10	16G-25412-00	ARANDELA	2				
11	90170-10219	TUERCA	6				
12	93210-57428	ANILLO O	1				
13	5KS-25304-00	JUEGO DE RAYOS TRASEROS	1				
14	94445-15607	ARO	1				
15	5V4-25398-00	CONTRAPESO DE RUEDA	1				UN
16	94117-15009	NEUMÁTICO (170/80-15M/C 77S)	1				DUNLOP
17	94217-15299	TUBO (150/170-90/80-15)	1				DUNLOP
18	94317-15180	BANDA DE ARO	1				DUNLOP
19	5EL-25381-00	EJE DE RUEDA	1				
20	90201-160T2	ARANDELA PLANA	1				
21	95604-16200	TUERCA DE AUTO-CIERRE	1				
22	5KS-25335-00	TAPA	1				
23	90387-177Y4	CASQUILLO CON VALONA	1				
24	4H7-25377-00	COLLAR DE RUEDA	1				



5KS7100-1310

FIG. 31 CALIBRE FRENO TRASERA

REF. NO.	CODIGO NO.	DESCRIPCION	BKSB				OBSERVACION
1	5KS-2582W-00	DISCO DE FRENO TRASEROS 2	1				
2	90109-083G4	PERNO	6				
3	5KS-2515A-20	AROS, MASA 2 (D)	1				
4	5EL-2580W-00	CALIBRE COMPLETO TRASEROS 2	1				
5	31A-W0057-00	.PISTON COMPLETO PINZA	1				
6	31A-W0047-00	..JUEGO DE RETENES DE PINZA	1				
7	3XF-W0045-50	.JUEGO DE COJIN DE FRENO	1				
8	29L-25919-00	.SOPORTE DE PASTILLAS	1				
9	3HE-25924-00	.PASADOR	2				
10	3GM-25925-00	.PRESILLA	2				
11	1J3-W0048-00	.CJTO TORNILLO DE PURGA	1				
12	51J-25836-00	.CUBIERTA PARA POLVO	1				
13	5EL-25819-01	SOPORTE DE CALIBRE	1				
14	90105-10638	TORNILLO CON ARANDELA	2				
15	90105-10010	TORNILLO CON ARANDELA	1				
16	90201-10140	ARANDELA PLANA	1				

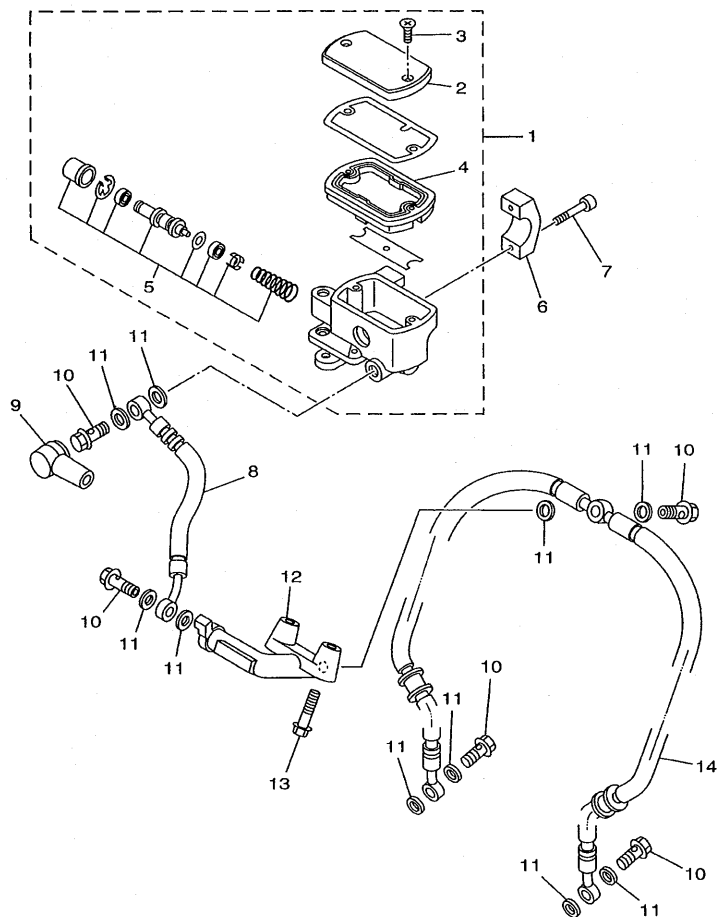


5KS4300-0320

FIG. 32 MANUBRIO. CABLE

REF. NO.	CODIGO NO.	DESCRIPCION	9K5B				OBSERVACION
1	5KS-26111-00	MANUBRIO	1				
2	5KS-23389-00	GUIA DE CABLE	1				
3	90464-18246	BRIDA	2				
4	90176-12052	TUERCA CORONA	2				
5	4NK-26241-00	EMPUNADURA (MI)	1				
6	5EL-26246-00	EXTREMO DE EMPUNADURA	2				
7	5EL-23469-00	TAPA DE PERNO	2				
8	4XY-26240-00	EMPUNADURA COMPLETA	1				
9	5KS-26311-00	CABLE DE ACELERADOR 1	1				
10	5KS-26312-00	CABLE DE ACELERADOR 2	1				
11	98507-05008	TORNILLO DE CABEZA CON PLANA	1				
12	5KS-26335-00	CABLE DE EMBRAGUE	1				
13	1E6-26342-00	FUNDA DE CABLE	1				
14	5EL-26280-01	ESPEJO COMPLETO (IZQUIERDO)	1				
15	5EL-26290-01	ESPEJO COMPLETO (DERECHO)	1				
16	5EL-26331-00	CABLE DE ARRANQUE	1				
17	90468-07179	PRESILLA	2				
18	90468-15139	PRESILLA	2				
19	90464-15192	BRIDA	4				

FIG. 33 CILINDRO MAESTRO DELANTERO



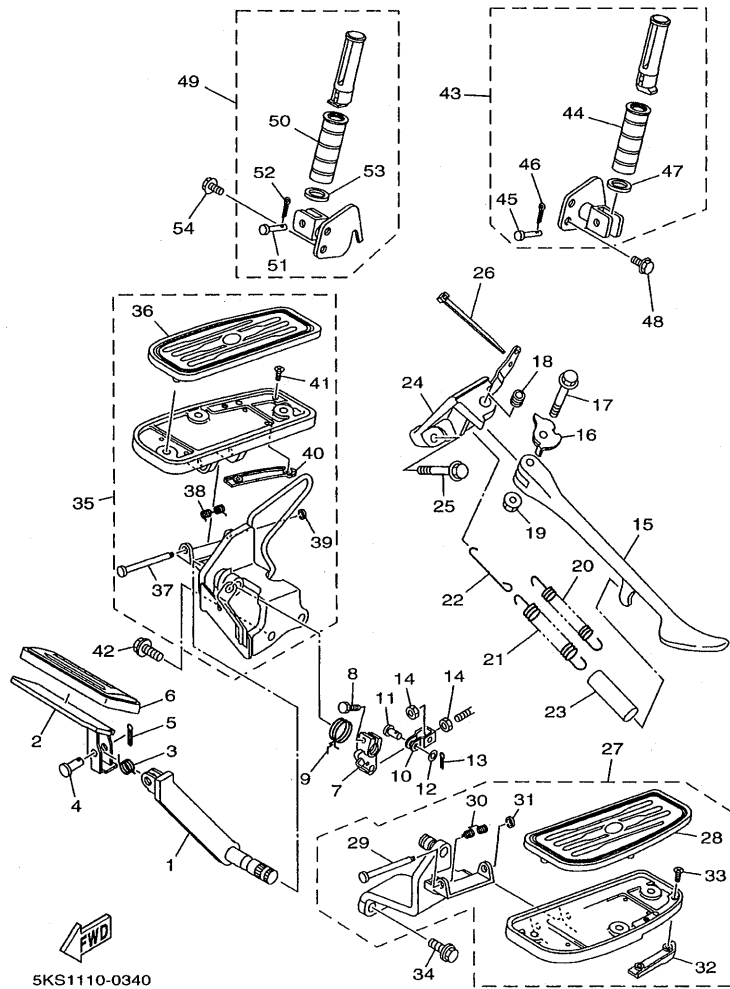
REF. NO.	CODIGO NO.	DESCRIPCION	5KSB				OBSERVACION
1	4TR-25870-01	CILINDRO MAESTRO COMPLETO	1				
2	4TR-25852-00	.TAPA DE TANQUE DE RESERVA	1				
3	98704-04012	.TORNILLO DE CABEZA PLANA	2				
4	4BH-25854-02	.DIAFRAGMA TANQUE RESERVA	1				
5	2KR-W0041-00	.JUEGO DE CILINDRO MAESTRO	1				
6	4TR-25867-00	SOPORTE DE CILINDRO MAESTRO	1				
7	91314-06025	PERNO	2				
8	5KS-25872-00	MANGUERA DE FRENO 1	1				
9	4L0-25862-01	FUNDA DE CILINDRO MAESTRO	1				
10	90401-10159	PERNO DE UNION	5				
11	90201-10118	ARANDELA PLANA	10				
12	5KS-25885-00	UNION	1				
13	95807-06030	TUERCA DE REBORDE	2				
14	5KS-25873-00	MANGUERA DE FRENO 2	1				



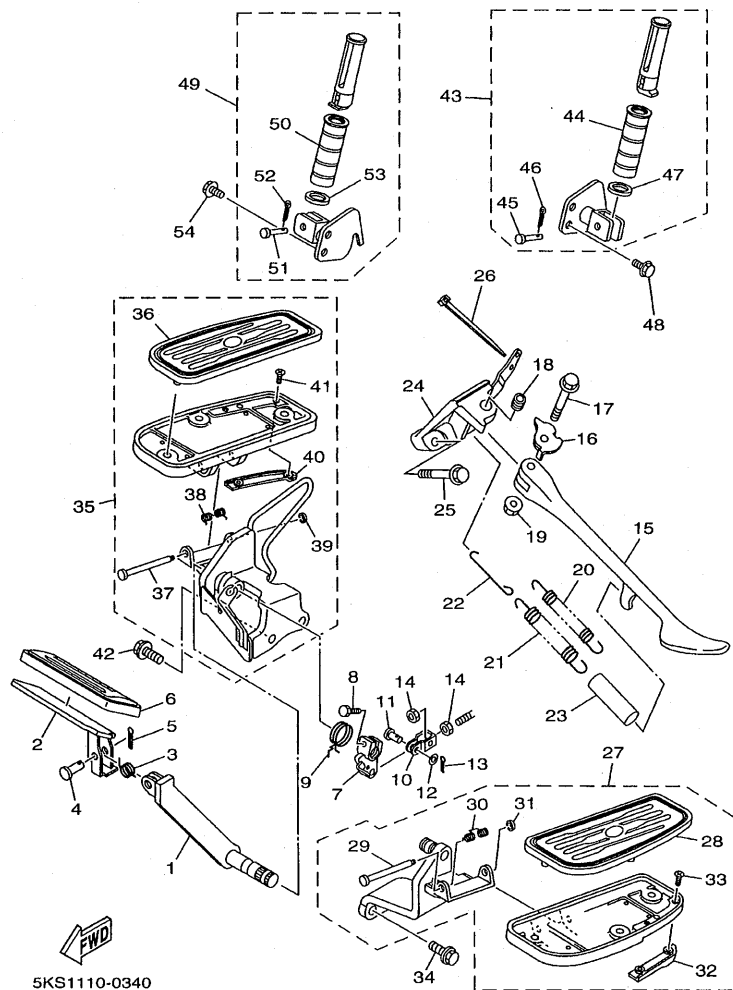
5KS1110-0330



FIG. 34 SOPORTE. APOYAPIE



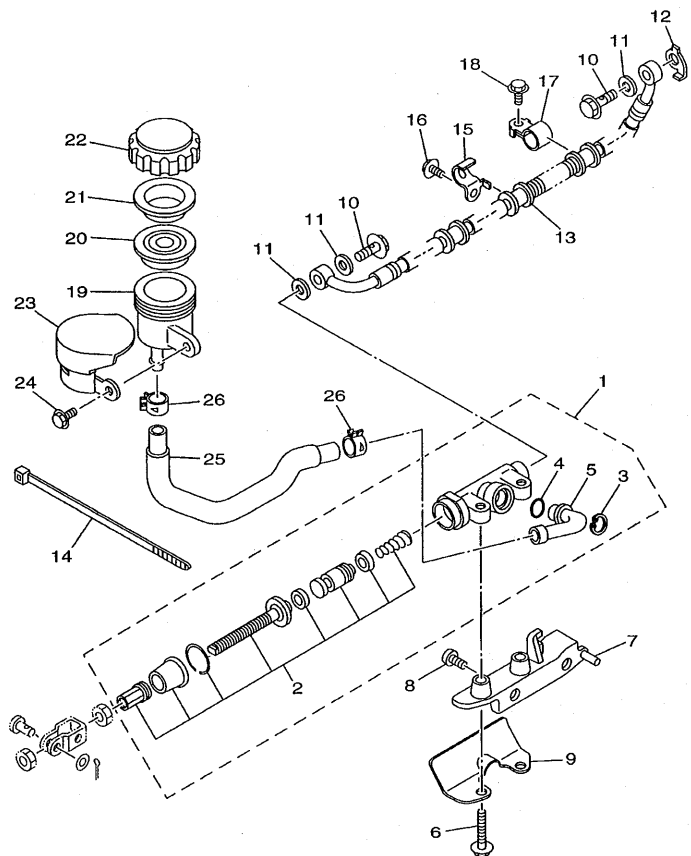
REF. NO.	CODIGO NO.	DESCRIPCION	5KSB				OBSERVACION
1	5KS-27211-00	PEDAL DE FRENO	1				
2	4NK-27242-00	PEDAL DE FRENO	1				
3	90508-186B1	RESORTE DE TORSION	1				
4	91701-06022	PASADOR DE ABRAZADERA	1				
5	91401-20012	PASADOR DE CHAVETA	1				
6	4NK-27285-00	TAPA	1				
7	5EL-27262-00	PALANCA	1				
8	97004-06020	PERNO	1				
9	5EL-27216-00	RESORTE DE PEDAL DE FRENO	1				
10	4BP-27222-00	UNION	1				
11	90240-08124	PASADOR CON HOYO	1				
12	90201-08083	ARANDELA PLANA	1				
13	91401-20012	PASADOR DE CHAVETA	1				
14	95307-08700	TUERCA	2				
15	4KU-27311-13	PUNTAL LATERAL	1				
16	5EL-27322-01	ARANDELA	1				
17	90105-10012	TORNILLO CON ARANDELA	1				
18	90387-1003G	CASQUILLO CON VALONA	1				
19	95607-10200	TUERCA DE AUTO-CIERRE	1				
20	90506-23490	RESORTE DE TENSION	1				
21	90506-29507	RESORTE DE TENSION	1				
22	5EL-27315-00	CONEXION DE PUNTAL LATERAL	1				
23	90445-16641	TUBO (L60)	1				
24	5EL-27321-00	SOPORTE DE PUNTAL LATERAL	1				
25	95817-10045	TUERCA DE REBORDE	2				
26	1UA-82591-00	BANDA	1				
27	5KS-27410-00	APOYAPIE DELANTERO (MI)	1				



5KS1110-0340

FIG. 34 SOPORTE. APOYAPIE

REF. NO.	CODIGO NO.	DESCRIPCION	5KSB				OBSERVACION
28	4XY-27413-00	.CUBIERTA DE APOYAPIE	1				
29	4NK-27427-00	.EJE	1				
30	4NK-27426-00	.RESORTE DE RETORNO	1				
31	99001-06600	.PRESILLA REDONDA	1				
32	4WM-27496-00	.MOLDURA1	1				
33	90152-05008	.TORNILLO EMBUTIDO	2				
34	90105-102A3	TORNILLO CON ARANDELA	2				
35	5KS-27420-00	APOYAPIE DELANTERO (MD)	1				
36	4XY-27423-00	.CUBIERTA DE APOYAPIE	1				
37	4NK-27427-00	.EJE	1				
38	4NK-27426-00	.RESORTE DE RETORNO	1				
39	99001-06600	.PRESILLA REDONDA	1				
40	4WM-27497-00	.MOLDURA2	1				
41	90152-05008	.TORNILLO EMBUTIDO	2				
42	90105-102A3	TORNILLO CON ARANDELA	2				
43	5EL-27430-00	APOYAPIE POSTERIOR COMPLETO 1	1				
44	4WM-27433-00	.CUBIERTA APOYAPIE TRASERO	1				
45	91701-06032	.PASADOR DE ABRAZADERA	1				
46	91401-20012	.PASADOR DE CHAVETA	1				
47	90201-210U0	.ARANDELA PLANA	1				
48	90105-082A5	TORNILLO CON ARANDELA	2				
49	5EL-27440-00	APOYAPIE POSTERIOR COMPLETO 2	1				
50	4WM-27433-00	.CUBIERTA APOYAPIE TRASERO	1				
51	91701-06032	.PASADOR DE ABRAZADERA	1				
52	91401-20012	.PASADOR DE CHAVETA	1				
53	90201-210U0	.ARANDELA PLANA	1				
54	90105-082A5	TORNILLO CON ARANDELA	2				



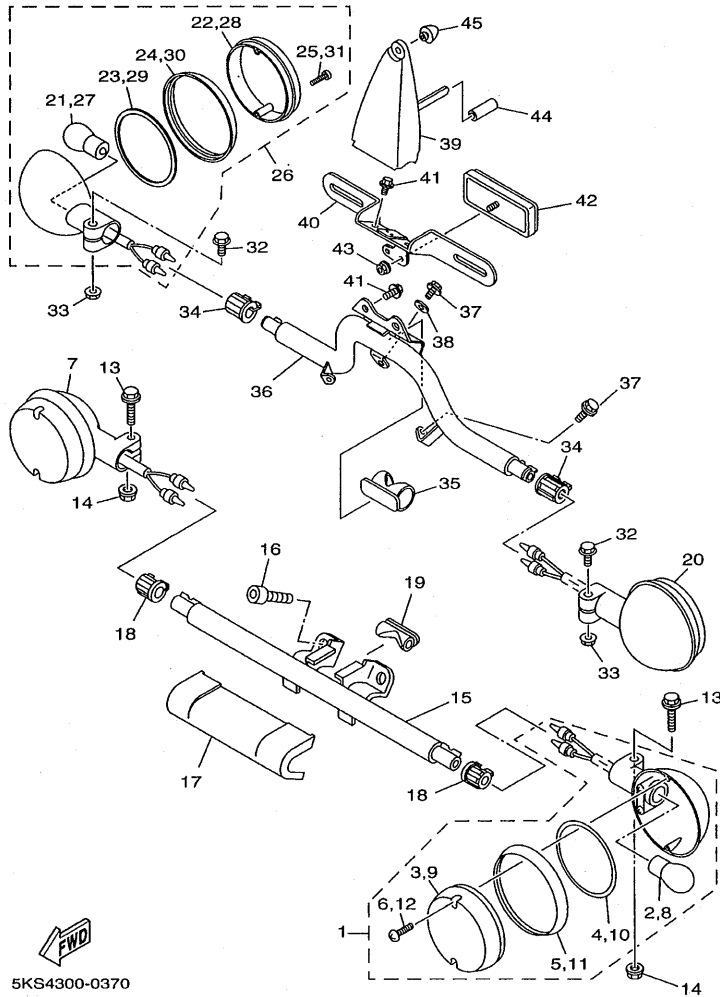
5EL1351-9350

FIG. 35 CILINDRO MAESTRO TRASERO

REF. NO.	CODIGO NO.	DESCRIPCION	EX	KB				OBSERVACION
1	5EL-2583V-00	CILINDRO, MAESTRO TRASERO	1					
2	5EL-W0042-50	JUEGO DE CILINDRO MAESTRO	1					
3	2VN-25866-00	.PRESILLA REDONDA	1					
4	93210-15620	.ANILLO O	1					
5	3LD-2582A-00	.CONECTOR	1					
6	95027-08035	PERNO, DE BRIDA	2					
7	5EL-25867-00	SOPORTE DE CILINDRO MAESTRO	1					
8	92014-08016	PERNO	2					
9	5EL-27491-00	PROTECTOR	1					
10	90401-10159	PERNO DE UNION	2					
11	90201-10118	ARANDELA PLANA	3					
12	5EL-25844-00	ARANDELA DE CIERRE	1					
13	5EL-2581J-01	MANGUERA, DE FRENO 4	1					
14	1UA-82591-00	BANDA	7					
15	3XV-25876-00	SOPORTE DE MANGUERA FRENO 2	1					
16	95027-06010	PERNO, DE BRIDA	1					
17	90461-10127	GRAPA	1					
18	95027-06010	PERNO, DE BRIDA	1					
19	31A-25894-01	TANQUE DE RESERVA	1					
20	360-25854-01	DIAFRAGMA TANQUE RESERVA	1					
21	2GU-25855-00	BUJE DE DIAFRAGMA	1					
22	2KF-25852-50	TAPA DE TANQUE DE RESERVA	1					
23	5EL-25888-00	CUBIERTA DE TANQUE DE RESERVA	1					
24	95027-06016	PERNO, DE BRIDA	1					
25	5EL-25895-00	MANGUERA DE TANQUE DE RESERVA	1					
26	90467-14057	PRESILLA	2					



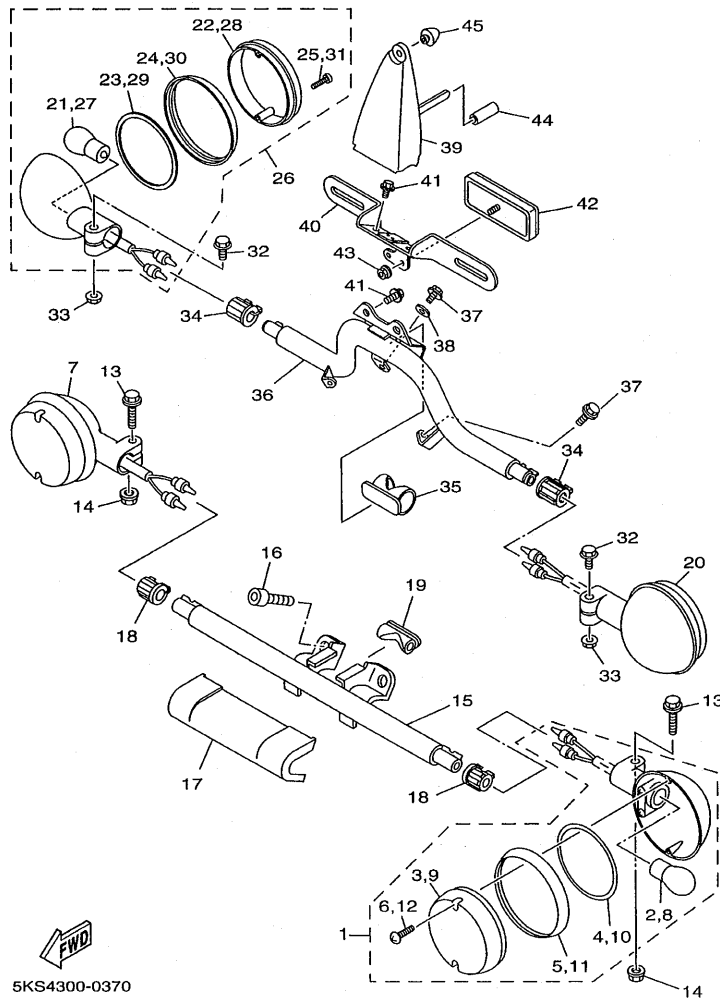
FIG. 37 LUZ DE DESTELLADOR



5KS4300-0370

REF. NO.	CODIGO NO.	DESCRIPCION	5KSB		OBSERVACION
1	2EN-83310-00	DESTELLADOR DE LUZ DELANT.	1		Go to P/N: PE0-MC-040092
2	2AE-83311-00	.BOMBILLA DE DESTELLADOR	1		Go to P/N: PE0-MC-040092
3	42X-83312-00	.LENTE DE DESTELLADOR	1		Go to P/N: PE0-MC-040092
4	42X-83313-00	.EMPAQUE DE LENTE DESTELLADOR	1		Go to P/N: PE0-MC-040092
5	42X-83363-00	.LENTES	1		Go to P/N: PE0-MC-040092
6	57M-83358-00	.TORNILLO ESPECIAL	2		Go to P/N: PE0-MC-040092
7	2EN-83320-00	DESTELLADOR DE LUZ DELANT.	1		Go to P/N: PE0-MC-040092
8	2AE-83311-00	.BOMBILLA DE DESTELLADOR	1		Go to P/N: PE0-MC-040092
9	42X-83312-00	.LENTE DE DESTELLADOR	1		Go to P/N: PE0-MC-040092
10	42X-83313-00	.EMPAQUE DE LENTE DESTELLADOR	1		Go to P/N: PE0-MC-040092
11	42X-83363-00	.LENTES	1		Go to P/N: PE0-MC-040092
12	57M-83358-00	.TORNILLO ESPECIAL	2		Go to P/N: PE0-MC-040092
13	95024-06030	PERNO, DE BRIDA	2		
14	95704-06500	TUERCA DE BRIDA	2		
15	5BN-2317V-00	APOYO 8	1		
16	91314-08016	PERNO	2		
17	4NK-23122-01	CUBIERTA EXTERIOR 1	1		
18	4NK-83321-00	AMORTIGUADOR DE DESTELLADOR 1	2		
19	4NK-83345-00	TAPON CIEGO	1		
20	2EN-83330-00	DESTELLADOR DE LUZ TRAS.COMPL.	1		Go to P/N: PE0-MC-040092
21	2AE-83311-00	.BOMBILLA DE DESTELLADOR	1		Go to P/N: PE0-MC-040092
22	2AE-83312-00	.LENTE DE DESTELLADOR	1		Go to P/N: PE0-MC-040092
23	42X-83313-00	.EMPAQUE DE LENTE DESTELLADOR	1		Go to P/N: PE0-MC-040092
24	42X-83363-00	.LENTES	1		Go to P/N: PE0-MC-040092
25	57M-83358-00	.TORNILLO ESPECIAL	2		Go to P/N: PE0-MC-040092
26	2EN-83340-00	DESTELLADOR DE LUZ COMPL.	1		Go to P/N: PE0-MC-040092
27	2AE-83311-00	.BOMBILLA DE DESTELLADOR	1		Go to P/N: PE0-MC-040092

FIG. 37 LUZ DE DESTELLADOR



5KS4300-0370

REF. NO.	CODIGO NO.	DESCRIPCION	5K/5B				OBSERVACION
28	2AE-83312-00	.LENTE DE DESTELLADOR	1				Go to P/N: PE0-MC-040092
29	42X-83313-00	.EMPAQUE DE LENTE DESTELLADOR	1				Go to P/N: PE0-MC-040092
30	42X-83363-00	.LENTES	1				Go to P/N: PE0-MC-040092
31	57M-83358-00	.TORNILLO ESPECIAL	2				Go to P/N: PE0-MC-040092
32	95024-06030	PERNO, DE BRIDA	2				
33	95704-06500	TUERCA DE BRIDA	2				
34	4NK-83321-00	AMORTIGUADOR DE DESTELLADOR 1	2				
35	4NK-83345-00	TAPON CIEGO	1				
36	5KS-2317W-10	APOYO 9	1				
37	95024-06012	PERNO, DE BRIDA	3				
38	90201-06043	ARANDELA PLANA	1				
39	5KS-84703-10	SOPORTE	1				
40	5KS-84751-10	SOPORTE DE LICENCIA	1				
41	95027-06010	PERNO, DE BRIDA	4				
42	3Y6-85130-02	REFLECTOR TRASERO COMPLETO	1				
43	95707-05500	TUERCA DE BRIDA	1				
44	90446-07114	TUBO RESEIRADERO	1				
45	5A8-21639-00	AMORTIGUADOR 2	1				

# PARTS NEWS

News No. M/C-04092 1/4

Date: August, 17, 2004

Signature: K. Otsuka

Model	XVS1100
Subject	PARTS CATALOGUE CORRECTIONS
CATALOGUE NO.	See the "List of Models and CATALOGUE No's below."

Please make the following corrections to your parts catalogue.

## 1. LIST CORRECTION FIG.37 FLASHER LIGHT

OLD Ref.No.	NEW Ref.No.	OLD P/No.	NEW P/No.	PART NAME	Q'TY	REMARKS	*1
1	←	2EN-83310-00	<b>2EN-83310-01</b>	FRONT FLASHER LIGHT ASSY 1	1	*Part number revision (FOR LEFT)	B
2	←	2AE-83311-00	←	. BULB, FLASHER (12V-21W)	1	*No part number change	
3	←	42X-83312-00	<b>42X-83312-10</b>	. LENS, FLASHER	1	*Part number revision	○
4	←	42X-83313-00	<b>1D6-83313-00</b>	. GASKET, FLASHER LENS	1		B ○
5	←	42X-83363-00	<b>1D6-83363-00</b>	. LENS, RIM	1		B ○
6	←	57M-83358-00	←	. SCREW, SPECIAL	2	*No part number change	
7	←	2EN-83320-00	<b>2EN-83320-01</b>	FRONT FLASHER LIGHT ASSY 2	1	*Part number revision (FOR RIGHT)	B
8	←	2AE-83311-00	←	. BULB, FLASHER (12V-21W)	1	*No part number change	
9	←	42X-83312-00	<b>42X-83312-20</b>	. LENS, FLASHER	1	*Part number revision	○
10	←	42X-83313-00	<b>1D6-83313-00</b>	. GASKET, FLASHER LENS	1		B ○
11	←	42X-83363-00	<b>1D6-83363-10</b>	. LENS, RIM	1		B ○
12	←	57M-83358-00	←	. SCREW, SPECIAL	2	*No part number change	

### \*1: Interchangeability

A	Old Parts	→	Old Parts
	New Parts	→	New Parts
B	Old Parts	→	Old Parts
	New Parts	→	New Parts
C	Old Parts	→	Old Parts
	New Parts	→	New Parts
○	These parts are interchangeable with a set		

Parts  
Manager  
Check

Service  
Manager  
Check

Parts  
Manager  
File

YAMAHA MOTOR CO.,LTD  
2500 Shingai Iwata Shizuoka 438-8501.Japan  
GLOBAL TECHNICAL PUBLICATION DIV.

# PARTS NEWS

News No. M/C-04092 2/4

Date: August, 17, 2004

Signature: K. Otsuka


Model	XVS1100
Subject	PARTS CATALOGUE CORRECTIONS
CATALOGUE NO.	See the "List of Models and CATALOGUE No's below."

## 1. LIST CORRECTION FIG.37 FLASHER LIGHT

OLD Ref.No.	NEW Ref.No.	OLD P/No.	NEW P/No.	PART NAME	Q'TY	REMARKS	*1
20	←	2EN-83330-00	<b>2EN-83330-01</b>	REAR FLASHER LIGHT ASSY 1	1	*Part number revision (FOR LEFT)	<b>B</b>
21	←	2AE-83311-00	←	. BULB, FLASHER (12V-21W)	1	*No part number change	
			<b>2AE-W8331-10</b>	<b>. LENS, FLASHER KIT</b>	<b>1</b>	*New setting parts	
22	-	2AE-83312-00	-	. LENS, FLASHER	-	*Deleted Parts	<b>*2</b>
	<b>22</b>		<b>2AE-83312-20</b>	. LENS, FLASHER	1	*Added Parts	
23	←	42X-83313-00	<b>1D6-83313-00</b>	. GASKET, FLASHER LENS	1	*Part number revision	<b>B</b>
24	←	42X-83363-00	<b>1D6-83363-10</b>	. LENS, RIM	1	*Part number revision	<b>B</b>
25	←	57M-83358-00	←	. SCREW, SPECIAL	2	*No part number change	

26	←	2EN-83340-00	<b>2EN-83340-01</b>	REAR FLASHER LIGHT ASSY 2	1	*Part number revision (FOR RIGHT)	<b>B</b>
27	←	2AE-83311-00	←	. BULB, FLASHER (12V-21W)	1	*No part number change	
			<b>2AE-W8331-00</b>	<b>. LENS, FLASHER KIT</b>	<b>1</b>	*New setting parts	
28	-	2AE-83312-00	-	. LENS, FLASHER	-	*Deleted Parts	<b>*2</b>
	<b>28</b>		<b>2AE-83312-10</b>	. LENS, FLASHER	1	*Added Parts	
29	←	42X-83313-00	<b>1D6-83313-00</b>	. GASKET, FLASHER LENS	1	*Part number revision	<b>B</b>
30	←	42X-83363-00	<b>1D6-83363-00</b>	. LENS, RIM	1	*Part number revision	<b>B</b>
31	←	57M-83358-00	←	. SCREW, SPECIAL	2	*No part number change	

### \*1: Interchangeability

A	Old Parts	→	Old Parts
	New Parts	→	New Parts
B	Old Parts	→	Old Parts
	New Parts	→	New Parts
C	Old Parts	→	Old Parts
	New Parts	→	New Parts
	These parts are interchangeable with a set		

### \*2: The composition parts of LENS FLASHER KIT

LENS, FLASHER KIT	LENS, FLASHER	GASKET, FLASHER LENS	LENS, RIM
<b>2AE-W8331-00</b>	2AE-83312-10	1D6-83313-00	1D6-83363-00
<b>2AE-W8331-10</b>	2AE-83312-20	1D6-83313-00	1D6-83363-10

\*Old LENS FLASHER are not interchangeable with new LENS FLASHER.

\*When you exchange old LENS FLASHER, please exchange in LENS FLASHER KIT.

Parts  
Manager  
Check

Service  
Manager  
Check

Parts  
Manager  
File

YAMAHA MOTOR CO.,LTD  
2500 Shingai Iwata Shizuoka 438-8501.Japan  
GLOBAL TECHNICAL PUBLICATION DIV.



# PARTS NEWS

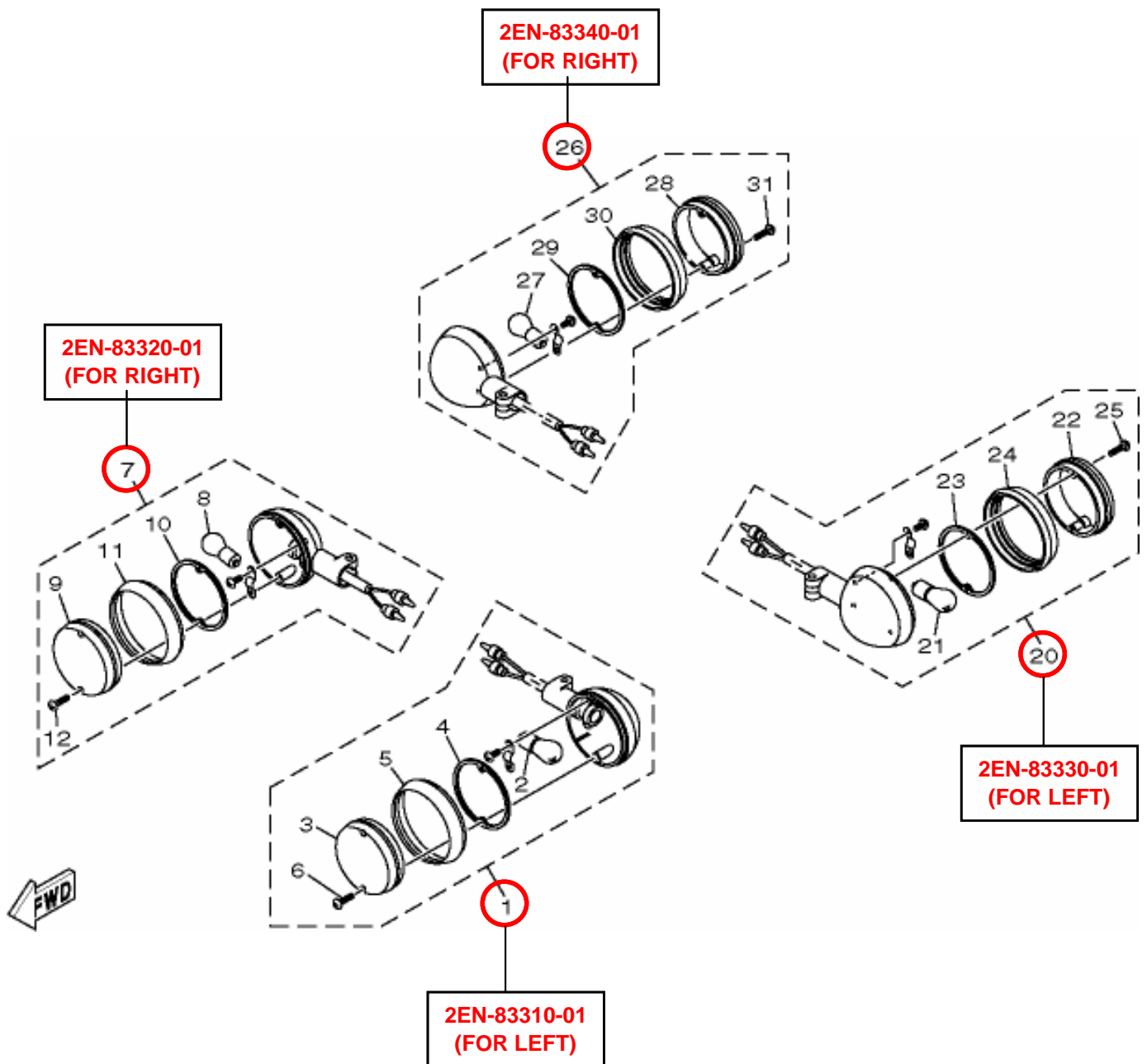
News No. M/C-04092 3/4

Date: August, 17, 2004

Signature: K. Otsuka

Model	XVS1100
Subject	PARTS CATALOGUE CORRECTIONS
CATALOGUE NO.	See the "List of Models and CATALOGUE No's below."

## 2. ILLUSTRATION CORRECTION



Parts  
Manager  
Check

Service  
Manager  
Check

Parts  
Manager  
File

YAMAHA MOTOR CO., LTD  
2500 Shingai Iwata Shizuoka 438-8501, Japan  
GLOBAL TECHNICAL PUBLICATION DIV.

# PARTS NEWS



News No. M/C-04092 4/4

Date: August, 17, 2004

Signature: K. Otsuka

Model	XVS1100
Subject	PARTS CATALOGUE CORRECTIONS
CATALOGUE NO.	See the "List of Models and CATALOGUE No's below."

### 3. LIST of Models and CATALOGUE No's.

The applicable MODELS, MODEL CODES, and CATALOGUE No's are as follows.

MODEL NAME	MODEL CODE	MODEL YEAR	Starting Serial No.	FIG.NO.	CATALOGUE NO.
XVS1100A	5KS4	2000	*	37	105KS-300E1
XVS1100A	5KS4	2000	*	37	105KS-332G1
XVS1100A	5KS4	2000	*	37	105KS-351F1
XVS1100A	5KS4	2000	*	37	105KS-352S1
XVS1100AM	5KS5	2000	*	37	105KS-700E1
XVS1100AN	5KSA	2001	*	37	115KS-700E1
XVS1100A	5KSB	2001	*	37	115KS-300E1
XVS1100A	5KSB	2001	*	37	115KS-332G1
XVS1100A	5KSB	2001	*	37	115KS-351F1
XVS1100A	5KSB	2001	*	37	115KS-352S1
XVS1100AP	5KSF	2002	*	37	1A5KS-700E1
XVS1100A	5KSG	2002	*	37	1A5KS-300E1
XVS1100A	5KSG	2002	*	37	1A5KS-332G1
XVS1100A	5KSG	2002	*	37	1A5KS-351F1
XVS1100A	5KSG	2002	*	37	1A5KS-352S1
XVS1100AWR	5KSM	2003	*	37	1B5KS-700E2
XVS1100A	5KSN	2003	*	37	1B5KS-300E2
XVS1100A	5KSN	2003	*	37	1B5KS-332G2
XVS1100A	5KSN	2003	*	37	1B5KS-351F2
XVS1100A	5KSN	2003	*	37	1B5KS-352S2

\* These changes are applied from initial production.

Thank you very much for your cooperation.

Parts  
Manager  
Check

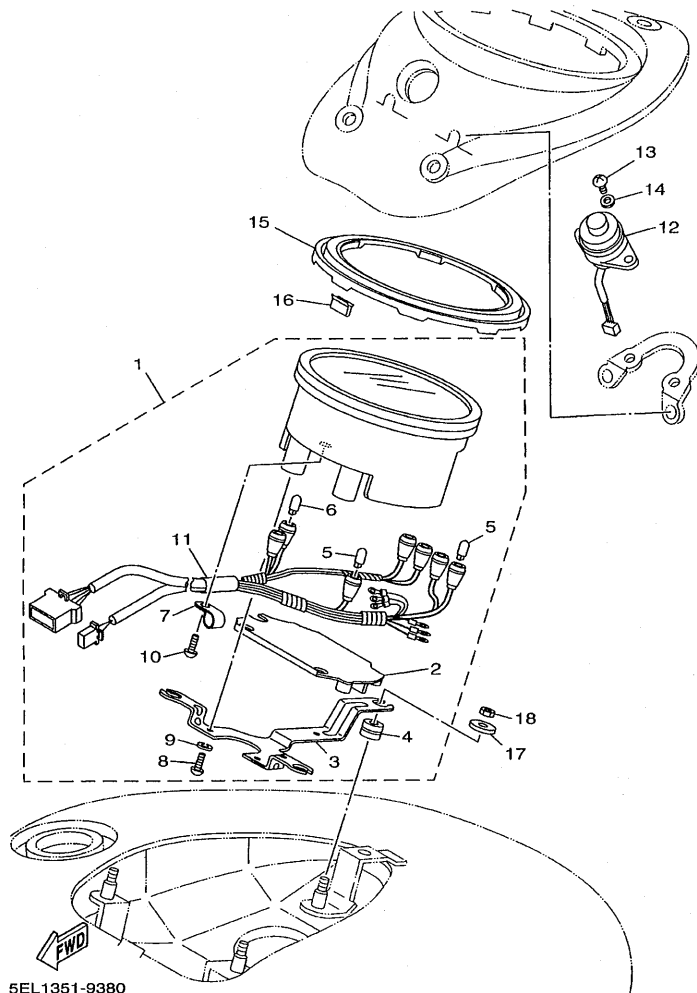
Service  
Manager  
Check

Parts  
Manager  
File

YAMAHA MOTOR CO.,LTD  
2500 Shingai Iwata Shizuoka 438-8501.Japan  
GLOBAL TECHNICAL PUBLICATION DIV.



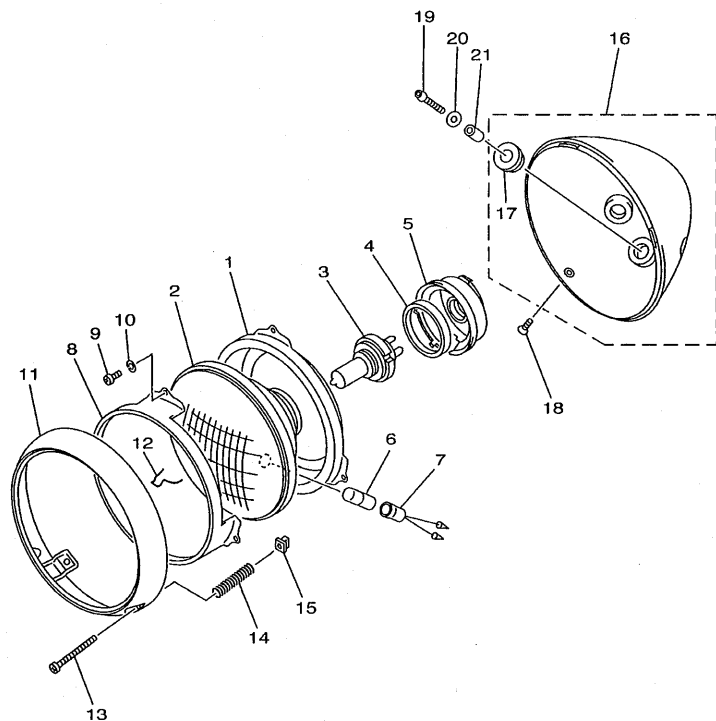
FIG. 38 MEDIDOR



5EL1351-9380

REF. NO.	CODIGO NO.	DESCRIPCION	5K5B				OBSERVACION
1	5KS-83500-11	VELOCIMETRO COMPLETO	1				
2	4NK-83579-00	.CUBIERTA DE MEDIDOR 2	1				
3	5EL-83519-00	.SOPORTE DE MEDIDOR	1				
4	4NK-83523-00	.AMORTIGUADOR	3				
5	2GV-83517-00	.BOMBILLA (12V-1.7W, T6.5)	5				
6	4NK-83517-00	.BOMBILLA (12V-1.4W, T6.5)	2				
7	5EL-8357E-00	.GRAMPA	1				
8	98507-04010	.TORNILLO DE CABEZA CON PLANA	3				
9	92907-04100	.ARANDELA	3				
10	97707-40012	.TORNILLO ROSCA HEMBRA	1				
11	5EL-83509-00	.ENCASTRE DE CABLE COMPLETO	1				
12	4NK-8358J-00	INTERRUPTOR CONTROL MEDIDOR	1				
13	98507-05012	TORNILLO DE CABEZA CON PLANA	2				
14	92907-05600	ARANDELA	2				
15	5EL-28346-00	MOLDURA	1				
16	1FK-2171H-00	GUIA	8				
17	90201-05036	ARANDELA PLANA	3				
18	95307-05600	TUERCA	3				

FIG. 39 FARO DELANTERO

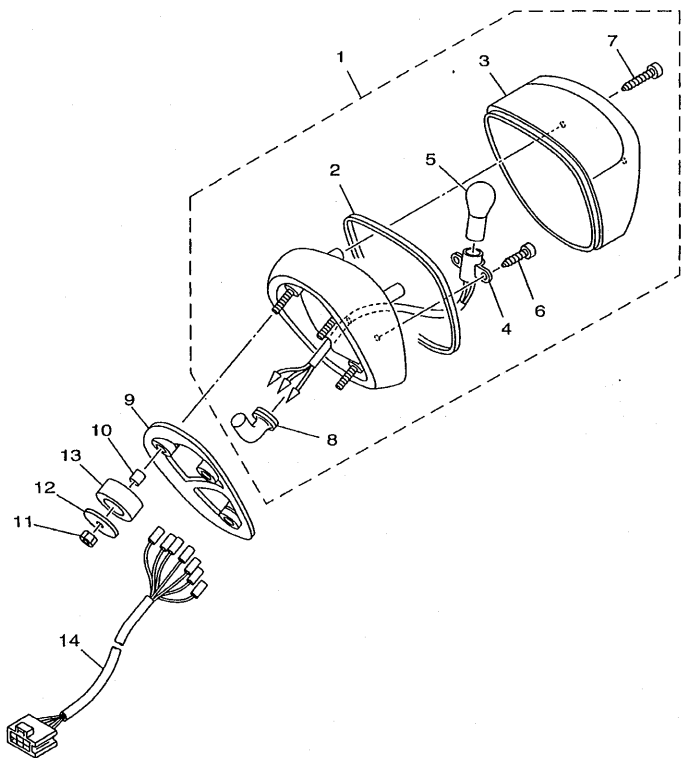


REF. NO.	CODIGO NO.	DESCRIPCION	5K39				OBSERVACION
1	4NK-84394-00	ANILLO DE MONTAJE	1				
2	2K3-84321-40	LENTE COMPLETO	1				
3	2F9-84314-00	BOMBILLA (12V-60/55W)	1				(H4) HALOGEN
4	2F9-84375-00	PLACA FIXATION DE BOMBILLO	1				
5	2F9-84397-01	CUBIERTA DE ENCASTRE	1				
6	4E2-84347-00	BOMBILLA (12V-4W)	1				
7	306-84346-30	ENCASTRE DE LUZ PILOTO	1				
8	2F9-84395-00	ANILLO DE RETEN	1				
9	98502-04008	TORNILLO DE CABEZA CON PLANA	3				
10	92902-04100	ARANDELA	3				
11	4NK-84315-00	ARO DE FARO DELANTERO	1				
12	290-84124-21	JUEGO DE RESORTES	1				
13	341-84331-60	TORNILLO DE AJUSTE DE ARO	2				
14	5G2-84332-60	RESORTE DE TORNILLO	2				
15	198-84334-60	TUERCA DE AJUSTE	2				
16	5KS-84330-00	CUERPO COMPLETO	1				
17	42X-84366-00	AMORTIGUADOR FARO DELANTERO	3				
18	98704-05012	TORNILLO DE CABEZA PLANA	2				
19	92017-06025	PERNO	3				
20	90201-060A3	ARANDELA PLANA	3				
21	90387-0610J	CASQUILLO CON VALONA	3				



5BN4351-8360

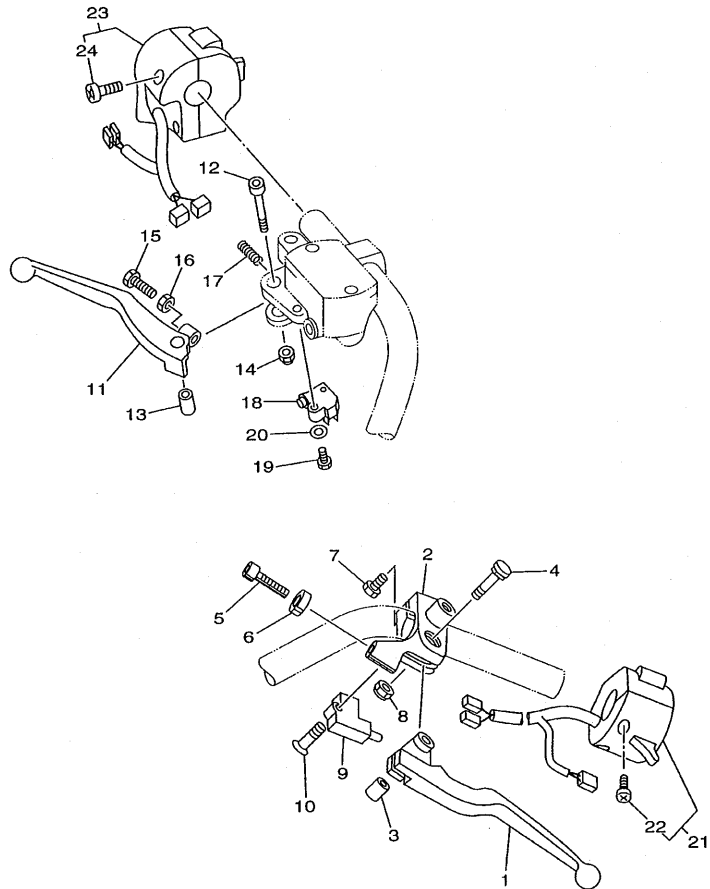
FIG. 40 LUZ DE COLA



5BN4351-8370

REF. NO.	CODIGO NO.	DESCRIPCION	9K5B				OBSERVACION
1	5BN-84700-11	FARO TRASERO COMPLET.	1				
2	4NK-84702-00	.EMPAQUE LENTE FARO TRASERO	1				
3	4YP-84721-00	.LENTE DE FARO TRASERO	1				
4	5BN-84735-00	.CABLE COMPLETA	1				
5	31L-84714-00	.BOMBILLA (12V-21/5W)	1				
6	97707-40516	.TORNILLO ROSCA HEMBRA	2				
7	97780-40525	.TORNILLO ROSCA HEMBRA	3				
8	5BN-84154-00	.ANILLO PROTECTOR	1				
9	4NK-84527-01	AMORTIGUADOR	1				
10	90387-07038	CASQUILLO CON VALONA	3				
11	95307-06600	TUERCA	3				
12	90201-065G8	ARANDELA PLANA	3				
13	5BN-84553-00	AMORTIGUADOR	3				
14	5KS-84717-00	CABLE DE FARO TRASERO	1				

FIG. 41 INTERRUPTOR DE MANIJA. PALANCA

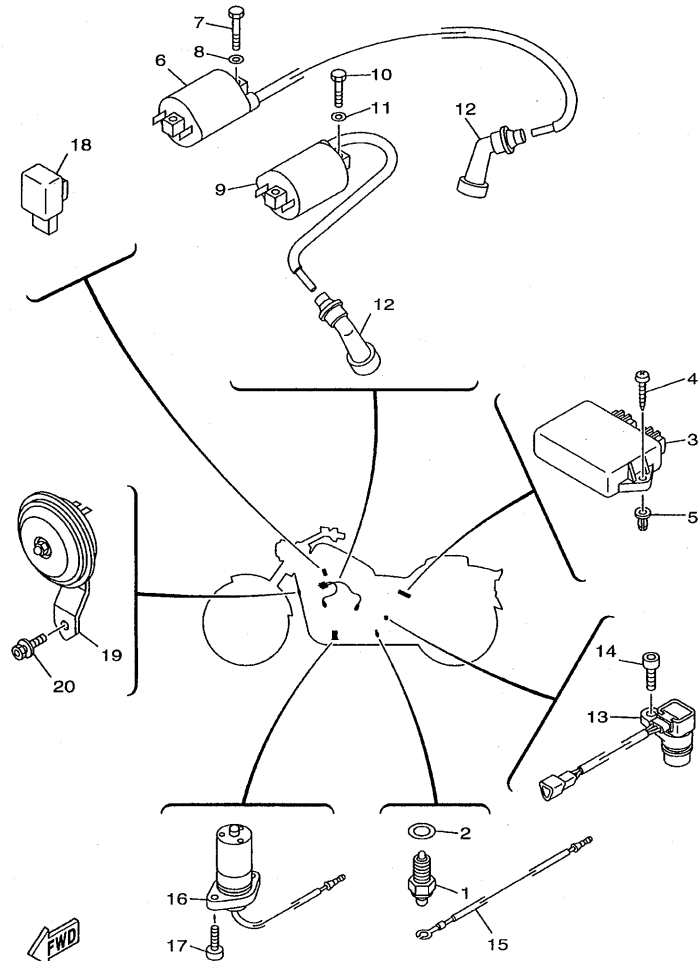


REF. NO.	CODIGO NO.	DESCRIPCION	EK/SB				OBSERVACION
1	5BN-83912-00	PALANCA 1	1				
2	5BN-82911-00	SOPORTE DE LEVA 1	1				
3	4TR-83913-00	COLLAR DE PALANCA 1	1				
4	4TR-83945-00	PERNO DE PALANCA	1				
5	90123-08046	PERNO	1				
6	90179-08148	TUERCA	1				
7	97004-06020	PERNO	1				
8	95604-06100	PERNO DE PUNTAL	1				
9	3YX-82917-00	INTERRUPTOR	1				
10	98707-03020	TORNILLO DE CABEZA PLANA	1				
11	5BN-83922-00	PALANCA 2	1				
12	90110-06074	TORNILLO ALLEN	1				
13	36Y-83913-01	COLLAR DE PALANCA 1	1				
14	95607-06100	TUERCA AUTOBLOCANTE	1				
15	90149-06131	TORNILLO DE REGLAJE	1				
16	90170-06010	TUERCA	1				
17	90501-10312	RESORTE DE COMPRESION	1				
18	36Y-83980-01	INTERRUP.PARADA DELANTERO	1				
19	98507-04016	TORNILLO DE CABEZA CON PLANA	1				
20	92907-04600	ARANDELA	1				
21	5EL-83972-00	INTERRUPTOR DE MANIJA 4	1				
22	98580-05025	TORNILLO DE CABEZA CON PLANA	2				
23	5BN-83963-00	INTERRUPTOR DE MANIJA 3	1				
24	98504-05025	TORNILLO DE CABEZA CON PLANA	2				



5KS4300-0410

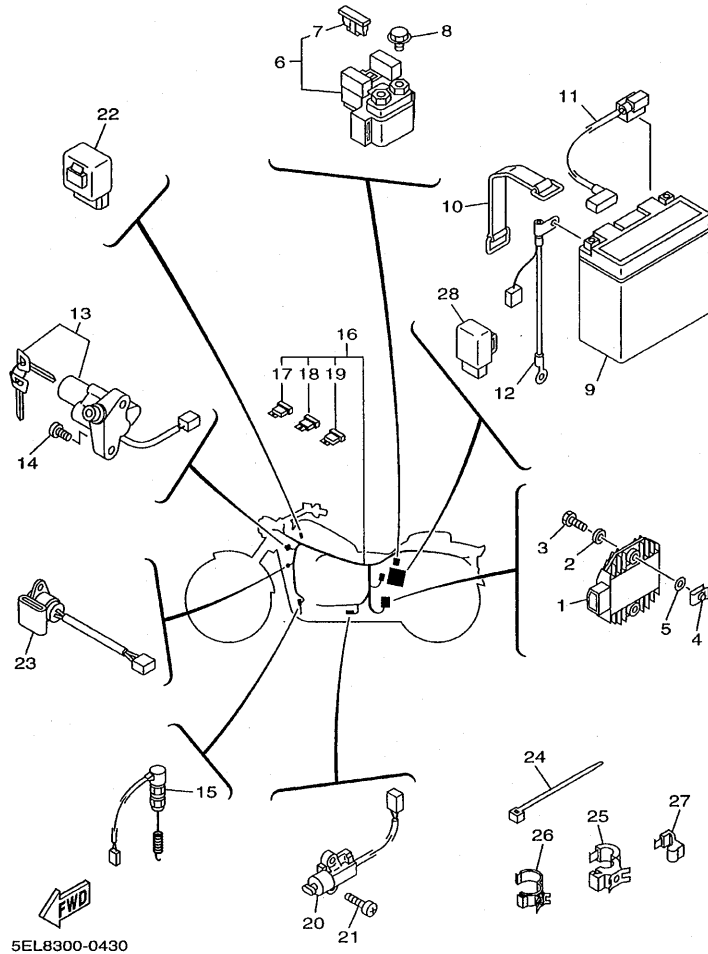
FIG. 42 EQUIPO ELECTRICO 1



SEL1351-9420

REF. NO.	CODIGO NO.	DESCRIPCION	5K5B				OBSERVACION
1	4KM-82540-00	INTERRUPTOR NEUTRAL COMPL	1				
2	90430-10148	JUNTA	1				
3	5EL-82305-00	UNIDAD DE ENCENDIDO COMPLETA	1				
4	97707-60016	TORNILLO ROSCA HEMBRA	2				
5	90338-08226	TAPON	2				
6	5EL-82310-00	BOBINA DE ENCENDIDO COMPLETA	1				
7	97007-05020	PERNO	2				
8	92907-05600	ARANDELA	2				
9	5EL-82320-00	BOBINA DE ENCENDIDO COMPLETA	1				
10	97007-05020	PERNO	2				
11	92907-05600	ARANDELA	2				
12	5EL-82370-00	TAPON DE BUJIA COMPLT	2				
13	5EL-83755-00	SENSOR DE VELOCI	1				
14	91317-06012	PERNO	1				
15	5EL-82509-00	CABLE SUBCONDUCTOR	1				
16	5EL-85720-00	MEDIDOR DE NIVEL DE ACEITE	1				
17	91317-06016	PERNO	2				
18	3GM-83350-01	RELE DE DESTELLADOR COMPL.	1				
19	55V-83371-00	BOCINA	1				
20	90105-082A5	TORNILLO CON ARANDELA	1				

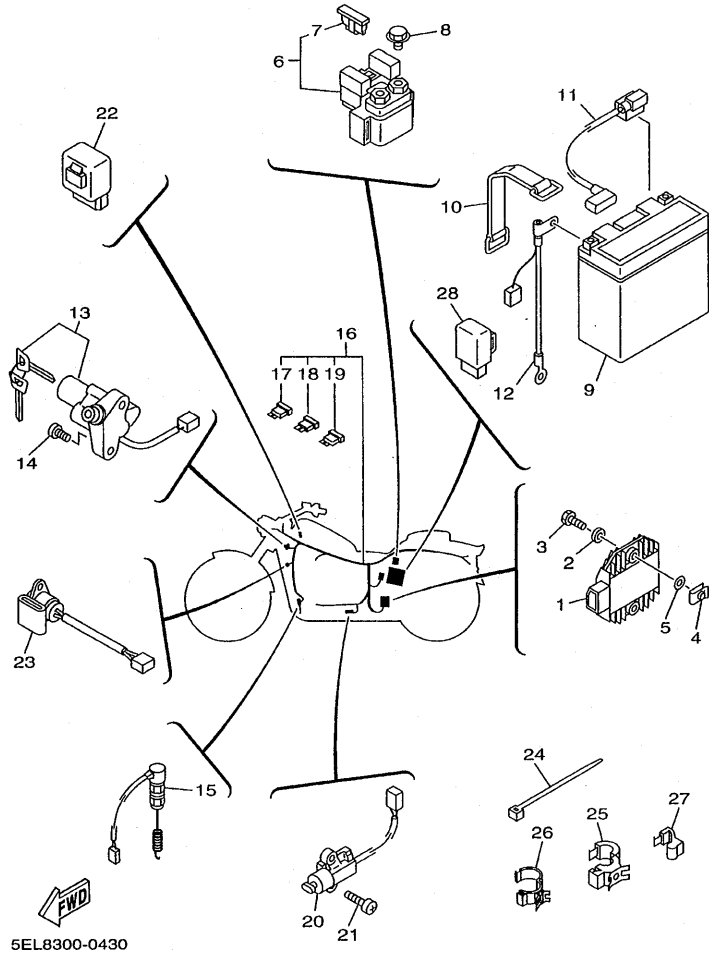
FIG. 43 EQUIPO ELECTRICO 2



REF. NO.	CODIGO NO.	DESCRIPCION	5KSB				OBSERVACION
1	5BN-81960-00	RECTIFICADOR Y REGULADOR	1				
2	90201-06727	ARANDELA PLANA	2				
3	97007-06025	PERNO	2				
4	90183-06053	TUERCA DE RESORTE	2				
5	90202-05187	ARANDELA DE PLANA	2				
6	4DN-81940-00	CONJUNTO ARRANCADOR RELEVO	1				
7	1AE-82151-00	.FUSIBLE (30A-BL)	2				
8	95027-06008	PERNO, DE BRIDA	2				
9	5EA-82100-10	BATWRIA COMPLETA (GT14B-4)	1				
10	118-82131-00	TIRANTE DE BATERIA	1				
11	5EL-82115-00	CABLE CONDUCTOR POSITIVO	1				
12	5EL-82116-00	CABLE CONDUCTOR NEGATIVO	1				
13	4VR-82501-01	LLAVE DE IGNICION COMPLT	1				
14	90149-08002	TORNILLO DE REGLAJE	2				
15	5EL-82530-00	INTERRUPTOR DE PARADA COMPLETO	1				
16	5EL-82590-01	CONJUNTO DE CABLES	1				
17	1NL-82151-00	.FUSIBLE (5A-BL)	2				
18	36Y-82151-00	.FUSIBLE (15A-BL)	3				
19	42X-82151-00	.FUSIBLE (10A-BL)	3				
20	3LD-82566-40	INTERRUPTOR	1				
21	90157-05079	TORNILLO CABEZA CONICA PLANA	2				
22	3EN-81950-00	RELE COMPLETO	1				
23	4TR-82560-00	INTER. DE TERMO	1				
24	1UA-82591-00	BANDA	8				
25	90464-20191	BRIDA	1				
26	90464-25217	BRIDA	1				
27	90464-10190	BRIDA	1				



FIG. 43 EQUIPO ELECTRICO 2



REF. NO.	CODIGO NO.	DESCRIPCION	5KSB			OBSERVACION
28	4XV-8195A-00	RELE COMPLETO	1			

INDICE NUMERICO

CODIGO NO.	REF. NO.	CODIGO NO.	REF. NO.	CODIGO NO.	REF. NO.	CODIGO NO.	REF. NO.	CODIGO NO.	REF. NO.	CODIGO NO.	REF. NO.
M12-T133A-00	D-4	4WM-11633-00	B-5	16G-13569-00	B-10	5EL-14431-00	B-11	1A8-14953-00	B-14	5EL-17151-00	C-9
2KR-W0041-00	E-8	5EL-11650-10	B-5	5EL-13586-00	B-10	5EL-14432-00	B-11	5DM-14985-00	B-12	4X7-17211-00	C-9
5EL-W0042-50	E-11	4X7-11654-01	B-5	5EL-13596-00	B-10	5EL-14437-00	B-10	4YW-14987-00	B-13	5EL-17221-00	C-9
3XF-W0045-50	E-6	4X7-11656-00	B-5	3LN-13907-00	D-15	5EL-14451-00	B-10	5EL-14987-00	B-10	5EL-17231-00	C-9
4EB-W0045-00	E-4	4X7-11656-10	B-5	5EL-1410A-00	B-12	4TR-14452-00	B-10		B-13	5EL-17241-00	C-9
31A-W0047-00	E-6	4X7-11656-20	B-5	5EL-14103-00	B-14	5EL-14452-00	B-10	11H-14991-00	B-13	5EL-17251-00	C-9
4FU-W0047-00	E-4	4X7-11656-30	B-5	4XY-14105-00	B-12	5EL-14453-00	B-11	5EL-14991-00	B-14	5EL-17402-00	C-9
1J3-W0048-00	E-6	4X7-11656-40	B-5	5EL-14107-12	B-12	5EL-14454-00	B-11	5KS-15100-00	C-3	5EL-17411-00	C-9
51L-W0048-00	E-4	5G5-11656-00	B-5	5EL-14112-00	B-12	5EL-14455-00	B-11	2H7-15361-00	C-4	4X7-17524-00	C-10
31A-W0057-00	E-6	5G5-11656-10	B-5	22F-14117-00	B-14	5EL-14462-00	B-11	3F9-15362-00	C-4	42X-17526-01	C-10
5KS-W0057-00	E-4	5G5-11656-20	B-5	3F7-14133-00	B-14	5EL-14463-00	B-11	4X7-15388-00	C-4	31A-17527-00	C-10
4VR-W2341-20	D-11	2J2-12111-01	B-6	812-14137-00	B-14	41R-14489-00	B-15	5EL-15411-00	C-4	3H5-17529-00	C-10
5EL-Y1757-00	C-10	4X7-12116-00	B-6	35H-14139-00	B-14	5EL-14499-00	B-11	5EL-15417-00	C-4	4X7-17531-00-15	C-10
5KS-Y2151-00-33	D-2	4X7-12117-00	B-6	5DM-14141-40	B-13	5DM-14561-00	B-12	5EL-15421-00	C-4	4X7-17531-00-30	C-10
5KS-Y2151-70-4X	D-2	4X7-12118-00	B-6	4KM-14142-17	B-12	5EL-14561-00	B-13	5EL-15423-00	C-5	4X7-17531-00-50	C-10
5KS-Y2161-00-33	D-2	341-12119-02	B-6	354-14147-00	B-12	583-14561-00	B-12	5EL-15451-00	C-4	1J7-17537-Y0-30	D-9
5KS-Y2161-70-4X	D-2	5A8-12121-00	B-6	5EL-14148-00	B-10	1FN-14565-00	B-13	5EL-15462-00	C-4	1J7-17537-Y0-40	D-9
5EL-Y2410-10-W7	D-14	42X-12151-00	B-6	5EL-14149-00	B-14	4WM-14565-00	B-13	5EL-15484-00	C-4	1J7-17537-Y0-50	D-9
5EL-Y2410-10-X7	D-14	4X7-12156-01	B-6	3LN-1416A-00	B-13	5EL-14577-00	B-13	5EL-15485-00	B-8	4X7-17551-00	C-10
5KS-11102-00	B-2	4X7-12159-00	B-6	127-14186-00	B-12	5EL-14592-00	B-13	4X7-15491-00	C-3	4X7-17554-00	C-10
4X7-1111F-00	B-3	5EL-12171-00	B-7	12R-14191-00	B-13	5EL-14610-10	B-15	5EL-15512-00	C-6	5EL-17556-00	C-10
5KS-1111H-00	B-2	5EL-12176-00	B-7	31H-14194-00	B-13	3EG-14613-00	B-15	5EL-15515-00	C-6	5EL-17558-00	C-10
5EL-1112M-00	B-3	5EL-12181-00	B-7	4KM-14194-00	B-12	4TR-14613-00	B-15	5EL-15517-10	C-6	5EL-17582-00	C-9
4X7-11133-10	B-2	5EL-12210-01	B-7	5EL-14197-00	B-14	5EL-14615-00	B-15	24W-15521-00	C-6	5EL-17583-00	C-9
5EL-11142-00	B-4	4FM-12213-00	B-4	127-14198-00	B-14	5KS-14620-00	B-15	5EL-15590-00	C-6	56W-17590-00	D-10
42X-11145-00	B-7		B-7	5EL-14212-00	B-14	5EL-14624-00	B-15	4X7-16111-00	C-7	5KS-18110-00	C-13
5EL-11152-00	B-4	5EL-12214-00	B-7	3DM-14216-00	B-14	5EL-14710-30	B-15	4X7-16150-02	C-7	4TR-18112-00	C-13
42X-11165-00	B-2	5KS-12215-00	B-4	4KM-14216-00	B-13	4NK-14714-00	B-15	2JN-16154-00	C-7	4DN-18115-20	C-13
5EL-11166-00	B-11	5EL-12228-00	B-7	3G2-1423A-59	B-12	42H-14714-10	C-2	22U-16321-00	C-8	5EL-18120-00	C-13
5EL-11181-00	B-2	5EL-12231-00	B-7	3G2-1423A-73	B-12	3XW-14755-00	B-15	4X7-16324-00	C-7	5EL-18140-00	C-13
5KS-11185-00	B-2	3YL-12232-00	D-4	1HX-1423E-25	B-12	5EL-14803-10	B-15	5EL-16325-00	C-8	5EL-18185-00	C-12
42H-11186-01	B-2	5EL-12241-00	B-7	1HX-14231-29	B-12	5EL-14806-00	B-15	1TA-16334-00	C-8	5EL-18511-00	C-12
5EL-11186-00	B-4	5EL-12247-00	B-7	3G2-14231-22	B-12	5EL-14871-00	B-15	1TA-16335-00	C-8	5EL-18512-00	C-12
4X7-11187-01	B-2	5EL-12682-00	B-11	5EL-14251-00	B-14	5EL-14872-00	B-15	5EL-16340-00	C-7	5EL-18513-00	C-12
5EL-11187-00	B-2	4X7-13171-00	B-8	5EL-14261-00	B-12	5EL-14875-00	B-2	2H7-16341-00	C-7	5EL-18531-00	C-12
5EL-11190-00	B-4	5EL-13300-01	B-8	5EL-14283-00	B-10	5EL-14881-00	C-2	4X7-16343-00	C-7	4X7-18536-00	C-12
214-11198-01	B-8	10L-13327-00	B-8	4NK-14285-00	B-13	5EL-14882-00	B-15	1TA-16351-01	C-8	5EL-18540-00	C-12
	D-10	4X7-13354-00	B-5	5EL-14294-00	B-10	5EL-14884-00	B-15	1TA-16352-00	C-8	136-18542-00	C-12
5KS-11311-00	B-4	4X7-13355-00	B-8	5EL-14348-00	B-10	5EL-1490H-00	B-13	4X7-16356-00	C-7	5KS-21110-00	C-14
5EL-11351-00	B-4	5EL-13405-00	B-8	5EL-14349-00	B-10	5KS-1490J-00	B-12	5EL-16357-00	C-7	5EL-21150-00	C-14
4X7-11363-01	B-2	5EL-13406-00	B-8	5EL-1440F-00	B-11	5EL-14900-00	B-12	5EL-16371-00	C-7	4DN-21268-00	C-14
5EL-11411-10	B-5	4X7-13440-01	B-9	5EL-14411-00	B-10	5KS-14901-00	B-12	4X7-16383-01	C-7		D-15
4X7-11534-00	B-7	5EL-13447-00	B-9	5EL-14413-00	C-5	5EL-14902-00	B-12	4X7-16384-00	C-7	4R8-21308-00	C-15
4X7-11536-00	B-7	5EL-13448-00	B-9	5EL-14414-00	B-11	5EL-14918-00	B-12	4X7-16385-00	C-7	5EL-21314-00	C-14
5EL-11540-01	B-7	5EL-13474-00	B-10	5EL-14417-00	B-10	5EL-14919-00	B-12	2H7-16395-01	C-7	5EL-21316-00	C-14
5EL-11550-01	B-7	4G0-13490-01	B-9	5EL-1442K-00	B-11	4KM-14933-00	B-12	2H7-16396-00	C-7	5EL-21317-00	C-14
1TA-11610-00	B-5	5EL-13542-00	B-15	5EL-14421-10	B-10	5EL-14935-00	B-13	5EL-17121-00	C-9	5EL-21318-00	C-14
5EL-11631-00	B-5	5EL-13544-01	B-15	29N-14425-00	D-4	5CY-14951-00	B-14	5EL-17141-00	C-9	5EL-21460-00	C-15

INDICE NUMERICO

CODIGO NO.	REF. NO.	CODIGO NO.	REF. NO.	CODIGO NO.	REF. NO.	CODIGO NO.	REF. NO.	CODIGO NO.	REF. NO.	CODIGO NO.	REF. NO.
5BN-21565-00	D-2	5EL-2178L-00	D-5	5BN-23174-00	D-11	5KS-24750-00	E-2	29L-25919-00	E-6	22U-46118-00-16	D-9
5KS-21570-00	D-2	3LS-221781-10	D-6	278-23181-50	D-12	5EL-25104-00	E-3	4BP-25919-00	E-4	22U-46118-00-18	D-10
5KS-21570-60	D-2	5KS-22110-00	D-7		D-13	5EL-25111-00	E-3	3HE-25924-00	E-6	22U-46118-00-20	D-10
5KS-21587-10	D-2	4X7-22124-00	D-7	43F-23188-10	D-12	5EL-2514A-00	E-4	3GM-25925-00	E-6	2H7-46122-00	D-9
5KS-21588-10	D-2	5EL-22129-00	D-7		D-13	5KS-2515A-00	E-4	3YX-25929-00	E-4	4H7-46123-01	D-9
5KS-21597-00	D-2	5EL-22141-00	D-7	5BN-23193-00	D-12	5KS-2515A-20	E-6	4TT-25937-00	E-4	4H7-46125-00	D-9
5KS-21598-00	D-2	4KM-2217A-00	D-7	5KS-23340-00	D-13	5KS-25181-00	E-3	5KS-26111-00	E-7	1J7-46129-Y1	C-10
30X-21621-00	D-4	2KT-2217M-00	D-7	5KS-23389-00	E-7	5KS-25188-00	E-3	4XY-26240-00	E-7	4H7-46152-00	D-9
5KS-21629-00	D-2	4VR-22184-00	D-7	5BN-23394-00	D-13	5KS-25304-00	E-5	4NK-26241-00	E-7	5EL-46153-00	D-9
5A8-21639-00	E-14	5EL-22189-00	D-7	1W1-23416-00	D-11	5EL-25311-00	E-5	5EL-26246-00	E-7	5EL-46154-00	D-10
4WM-2164F-00	D-2	5KS-22210-01	D-8	26H-23418-01	D-11	5KS-25335-00	E-5	5EL-26280-01	E-7	5EL-46171-00	D-10
4WM-2164G-00	D-2	5KS-23102-00	D-12	1E6-23441-10-98	D-8	5EL-25364-00	E-5	5EL-26290-01	E-7	4X7-46180-00	D-10
5KS-2165A-00	D-2	5KS-23103-00	D-12	4VR-23441-00	D-11	16G-25366-01	E-5	5KS-26311-00	E-7	5EL-46297-00	D-10
5KS-2165A-60	D-2	5KS-23110-00	D-12	4VR-23442-00	D-11	4H7-25377-00	E-5	5EL-26312-00	E-7	5EL-8135E-00	C-10
5KS-21669-00	D-2	3EN-23111-50	D-12	3DM-23445-00	D-11	5EL-25381-00	E-5	5EL-26331-00	E-7	5EL-81410-00	E-12
5KS-21669-10	D-2		D-13	3FV-23462-00	D-11	5V4-25398-00	E-3	5KS-26335-00	E-7	5EL-81450-10	E-12
5KS-21669-20	D-2	5EL-23118-00	D-12	5EL-23469-00	E-7			1E6-26342-00	E-7	5EL-81517-00	B-13
55K-21708-00	D-4		D-13	5EL-2411F-00	D-15	16G-25412-00	E-5	5KS-27211-00	E-9	5EL-81815-00	C-6
5EL-2171A-00	D-15	5BN-23121-00	D-13	5EL-2412F-00	D-15	5KS-2580T-00	E-4	5EL-27216-00	E-9	4XV-8182A-00	C-6
5EL-2171E-00	C-14	4NK-23122-01	E-13	5EL-2414G-00	D-15	5KS-2580U-00	E-4	4BP-27222-00	E-9	3KM-81826-00	C-6
1FK-2171H-00	E-15	5KS-23123-00	D-13	4VR-24161-01	D-14	5EL-2580W-00	E-6	4NK-27242-00	E-9	5A8-81840-10	C-6
1FK-2171L-00	D-14	4FM-23125-40	D-12	4VR-24162-01	D-14	5EL-2581J-01	E-11	5EL-27262-00	E-9	11H-81844-00	C-6
5EL-2171X-00	C-15	5KS-23126-00	D-12	2YK-24181-10	D-14	5EL-25819-01	E-6	4NK-27285-00	E-9	4G0-81844-00	C-6
5EL-2171Y-00	D-4	5BN-23131-00	D-13	5EL-24182-00	D-14	3LD-2582A-00	E-11	4KU-27311-13	E-9	1J7-81847-60	C-6
5KS-21711-00-MX	D-4	5KS-23133-00	D-13	4TR-24183-00	D-14	3JB-2582U-01	E-4	5EL-27315-00	E-9	5EL-81890-00	C-6
5KS-21711-00-33	D-4	5KS-23136-00	D-12	5EL-24188-00	D-14	5KS-2582W-00	E-6	5EL-27321-00	E-9	4DN-81940-00	F-6
3XV-21717-00	D-14	5KS-23141-00	D-12		D-15	5EL-2583V-00	E-11	5EL-27322-01	E-9	5EL-27322-01	E-9
5EL-2172A-00	D-4		D-13	5KS-24240-20	D-14	51J-25836-00	E-6	5KS-27410-00	E-9	3EN-81950-00	F-6
5KS-2172A-00	D-4	4EB-23144-00	D-12	5KS-24240-60	D-14	5EL-25844-00	E-11	4XY-27413-00	E-10	5BN-81960-00	F-6
5EL-2172F-00	D-4		D-13	5EL-24311-00	D-14	2KF-26852-50	E-11	5KS-27420-00	E-10	5EA-82100-10	F-6
5EL-2172G-00	D-4	4EB-23145-00	D-12	5EL-24313-00	D-14	4TR-25852-00	E-8	4XY-27423-00	E-10	4DH-82103-00	B-14
5EL-2172K-00	D-5		D-13	4EB-24398-00	D-14	360-25854-01	E-11	4NK-27426-00	E-10	5EL-82115-00	F-6
5EL-2172L-00	D-5	36Y-23146-10	D-12	5EL-24411-00	B-12	4BH-25854-02	E-8	4NK-27427-00	E-10	5EL-82116-00	F-6
5EL-2172M-00	D-5	4DW-23149-40	D-12	4SV-24453-00	B-13	2GU-25855-00	E-11	5EL-27430-00	E-10	5Y1-82122-00	D-4
5KS-21721-00-MX	D-4		D-13	4WM-24500-00	D-14	4L0-25862-01	E-8	4WM-27433-00	E-10	118-82131-00	F-6
5KS-21721-00-33	D-4	26H-23156-00	D-12	4X8-24512-00	D-14	2VN-25866-00	E-11	5EL-27440-00	E-10	3TJ-82131-00	D-5
5EL-21731-00	D-5		D-13	3AJ-24523-00	D-14	4TR-25867-00	E-8	5EL-27491-00	E-11	1AE-82151-00	F-6
3SP-21732-00	C-15	509-23158-L0	D-12	3AJ-24534-00	D-14	5EL-25867-00	E-11	4WM-27496-00	E-10	1NL-82151-00	F-6
	D-2		D-13	1FK-24560-00	D-14	4TR-25870-01	E-8	4WM-27497-00	E-10	36Y-82151-00	F-6
4NK-21735-00	D-2	5BN-23163-00	D-13	1FK-24566-00	D-14	5KS-25872-00	E-8	5EL-28100-10	E-2	42X-82151-00	F-6
5EL-21741-00	D-5	5BN-23165-00	D-13	5BN-24602-00	D-14	5KS-25873-00	E-8	5EL-28346-00	E-15	5EL-82305-00	F-5
5EL-21746-00	D-6	5BN-2317J-00	D-11	5KS-24710-00	E-2	3XV-25876-00	E-11	5EL-46101-00	D-9	5EL-82310-00	F-5
3BN-21747-00	C-14	5BN-2317V-00	E-13	5KS-24734-00	E-2	5KS-25885-00	E-8	1J7-46117-Y0-25	D-9	5EL-82320-00	F-5
	C-15	5KS-2317W-10	E-14	1T4-24741-00	E-2	5KS-25886-00	D-11	1J7-46117-Y0-30	D-9	5EL-82370-00	F-5
4TR-2175H-00	D-5	5EL-23170-00	D-12	22W-24741-00	E-2	5EL-25888-00	E-11	1J7-46117-Y0-40	D-9	4VR-82501-01	F-6
5EL-2177E-00	D-5	5BN-23171-00	D-12	5KS-2475H-00	E-2	31A-25894-01	E-11	1J7-46117-Y0-50	D-9	5EL-82509-00	F-5
5EL-2177G-00	D-4	4YR-23173-00	D-12	5BN-2475J-00	E-2	5EL-25895-00	E-11	22U-46118-00-12	D-9	5EL-82530-00	F-6
5EL-2177J-00	D-4		D-13	5KS-2475N-00	E-2	4TT-25914-00	E-4	22U-46118-00-14	D-9	4KM-82540-00	F-5

INDICE NUMERICO

CODIGO NO.	REF. NO.	CODIGO NO.	REF. NO.	CODIGO NO.	REF. NO.	CODIGO NO.	REF. NO.	CODIGO NO.	REF. NO.	CODIGO NO.	REF. NO.
4TR-82560-00	F- 6	290-84124-21	F- 2	90105-10638	E- 4	90179-12657	C- 14	90202-05193	D- 14	90401-16067	B- 8
3LD-82566-40	F- 6	5BN-84154-00	F- 3		E- 6	90179-14317	C- 11	90202-24190	D- 11	90413-07007	B- 10
5EL-82590-01	F- 6	2F9-84314-00	F- 2	90105-10727	D- 7	90179-16448	B- 5	90202-26142	D- 11	90430-06014	C- 3
1UA-82591-00	E- 11	4NK-84315-00	F- 2	90105-10781	C- 14	90179-25033	D- 11	90206-12074	C- 13	90430-10148	F- 5
	E- 9	2K3-84321-40	F- 2	90109-08667	B- 9	90179-44328	C- 10	90207-06380	E- 2	90430-15169	B- 8
	F- 6	5KS-84330-00	F- 2	90109-08006	E- 4	90179-88336	C- 10	90209-06205	B- 7	90430-17168	B- 3
5BN-82911-00	F- 4	341-84331-60	F- 2	90109-083G4	E- 6	90183-05061	D- 15	90209-21332	C- 9		B- 8
3YX-82917-00	F- 4	5G2-84332-60	F- 2	90109-10554	D- 8	90183-08053	D- 4	90209-28331	C- 9	90445-16641	E- 9
2EN-83310-00	E- 13	198-84334-60	F- 2	90110-05201	D- 15		D- 5	90214-20022	C- 7	90446-07114	E- 14
2AE-83311-00	E- 13	306-84346-30	F- 2	90110-08003	C- 4		F- 6	90215-20170	C- 8	90450-63096	B- 11
2AE-83312-00	E- 13	4E2-84347-00	F- 2	90110-08006	C- 5	90185-08097	B- 15	90215-20182	C- 7	90450-72095	B- 11
	E- 14	42X-84366-00	F- 2	90110-08074	F- 4	90185-14070	D- 9	90240-08124	E- 9	90461-06087	B- 14
42X-83312-00	E- 13	2F9-84375-00	F- 2	90110-08254	D- 5	90201-05036	E- 15	90267-40180	D- 5	90461-10127	E- 11
42X-83313-00	E- 13	4NK-84394-00	F- 2	90110-10182	C- 14	90201-060A3	F- 2	90269-07077	D- 2	90462-10003	C- 5
	E- 14	2F9-84395-00	F- 2	90116-08360	D- 9	90201-060S9	D- 14		D- 4	90462-10247	C- 5
2EN-83320-00	E- 13	2F9-84397-01	F- 2	90116-10344	B- 2	90201-06043	E- 14	90280-05048	B- 5	90464-10190	F- 6
4NK-83321-00	E- 13	4NK-84527-01	F- 3	90116-10593	D- 9	90201-06057	B- 4	90282-07042	C- 7	90464-12089	D- 5
	E- 14	5BN-84553-00	F- 3	90116-12469	B- 2	90201-06062	D- 5	90338-08163	D- 11	90464-15192	E- 7
2EN-83330-00	E- 13	5BN-84700-11	F- 3	90119-08060	D- 4	90201-065G8	F- 3	90338-08174	B- 11	90464-16021	D- 3
2EN-83340-00	E- 13	4NK-84702-00	F- 3	90119-06096	D- 4	90201-06727	F- 6	90338-08226	F- 5	90464-16025	D- 5
4NK-83345-00	E- 13	5KS-84703-10	E- 14		D- 5	90201-08083	E- 9	90340-14132	B- 8	90464-18246	E- 7
	E- 14	31L-84714-00	F- 3	90119-06236	C- 15	90201-101A4	B- 2		D- 10	90464-20191	F- 6
3GM-83350-01	F- 5	5KS-84717-00	F- 3	90123-08046	F- 4	90201-101J1	D- 7	90340-14135	D- 10	90464-25217	F- 6
57M-83358-00	E- 13	4YP-84721-00	F- 3	90149-06011	D- 14	90201-10118	E- 11	90340-14153	C- 4	90465-10264	B- 2
	E- 14	5BN-84735-00	F- 3	90149-06131	F- 4		E- 8	90340-32140	C- 4	90467-08092	B- 15
42X-83363-00	E- 13	5KS-84751-10	E- 14	90149-06298	B- 4	90201-10140	E- 6	90380-25125	B- 7	90467-10039	B- 10
	E- 14	3Y6-85130-02	E- 14	90149-06302	D- 5	90201-10591	B- 7	90387-0610J	F- 2	90467-10135	B- 10
55V-83371-00	F- 5	5EL-85720-00	F- 5	90149-08002	F- 6	90201-112U0	D- 7	90387-064E8	C- 3	90467-11028	D- 15
5KS-83500-11	E- 15	5EL-85885-00	B- 13	90151-06038	C- 15	90201-12166	C- 13	90387-065J6	B- 11	90467-11106	B- 10
5EL-83509-00	E- 15	90101-10303	B- 7	90151-06041	C- 12	90201-12588	C- 13	90387-066M3	B- 4	90467-12053	D- 15
2GV-83517-00	E- 15	90101-10659	D- 7	90152-05008	E- 10	90201-126A7	D- 7	90387-066Y6	D- 5	90467-12191	B- 10
4NK-83517-00	E- 15	90101-12673	D- 7	90157-05079	F- 6	90201-12688	C- 13	90387-07038	F- 3	90467-14015	B- 11
5EL-83519-00	E- 15	90105-06154	B- 7	90170-06010	F- 4	90201-14220	D- 11	90387-087A5	B- 4	90467-14057	E- 11
4NK-83523-00	E- 15		B- 8	90170-06228	C- 13	90201-14632	D- 9	90387-100T8	D- 7	90468-05113	B- 8
1FK-83526-00	D- 5	90105-08010	C- 11	90170-08173	B- 6	90201-14633	C- 10	90387-1003G	E- 9	90468-07179	E- 7
5EL-8357E-00	E- 15	90105-082A5	E- 10	90170-10219	E- 5	90201-151A7	C- 7	90387-124F4	C- 13	90468-08104	B- 15
4NK-83579-00	E- 15		F- 5	90170-20257	C- 8	90201-160T2	E- 5	90387-126T1	D- 7	90468-15139	E- 7
4NK-8358J-00	E- 15	90105-100A4	C- 14	90170-20274	C- 7	90201-165H4	B- 5	90387-127W0	D- 7	90480-01558	D- 4
5EL-83755-00	F- 5	90105-10003	C- 14	90170-22187	D- 4	90201-20276	C- 9	90387-172A5	D- 10		D- 5
3BT-83790-00	B- 14	90105-10004	C- 14	90176-10075	B- 2	90201-210U0	E- 10	90387-173M5	E- 3	90480-10289	D- 5
5BN-83912-00	F- 4	90105-10009	C- 14		D- 10	90201-220T0	D- 11		E- 5	90480-10627	B- 4
36Y-83913-01	F- 4	90105-10010	E- 6	90176-12052	E- 7	90201-243U9	D- 7	90387-173R6	E- 3	90480-12314	B- 11
4TR-83913-00	F- 4	90105-10012	E- 9	90176-22081	D- 11	90201-255A6	C- 10	90387-177Y4	E- 5	90480-12320	D- 4
5BN-83922-00	F- 4	90105-10013	C- 14	90179-08148	F- 4	90201-266L1	D- 10	90387-251E1	C- 11	90480-12550	D- 4
4TR-83945-00	F- 4	90105-101A9	D- 7	90179-09379	B- 5	90201-72008	C- 6	90401-10102	B- 8	90480-13018	B- 4
5BN-83963-00	F- 4	90105-102A3	E- 10	90179-10377	C- 14	90202-05180	D- 15	90401-10159	E- 11	90480-13398	B- 11
5EL-83972-00	F- 4	90105-10299	C- 14	90179-12325	B- 2	90202-05187	F- 6		E- 8	90480-15061	D- 2
36Y-83980-01	F- 4	90105-10444	C- 14	90179-12326	B- 2	90202-05191	B- 15	90401-16065	B- 3	90480-24186	D- 4

INDICE NUMERICO

CODIGO NO.	REF. NO.	CODIGO NO.	REF. NO.	CODIGO NO.	REF. NO.	CODIGO NO.	REF. NO.	CODIGO NO.	REF. NO.	CODIGO NO.	REF. NO.
90501-10312	F- 4	91317-06020	B- 10	93101-30084	D- 9	93311-43729	D- 9	95302-05700	B- 13	97707-50014	D- 4
90501-16491	D- 10		B- 11	93101-35099	C- 10	93311-44051	C- 10	95304-06700	C- 13	97707-50116	B- 10
90501-21133	B- 7		D- 5	93101-38098	D- 9	93316-01201	C- 9	95307-05600	E- 15	97707-50125	B- 11
90501-44455	B- 6	91317-06030	C- 3	93102-12106	C- 4	93316-01403	D- 9	95307-06600	F- 3	97707-60016	D- 5
90501-70762	C- 10		E- 12	93102-25044	E- 5	93317-21236	C- 4	95307-08700	C- 7		F- 5
90506-08227	C- 13	91317-06040	B- 8	93102-28022	E- 3	93317-22021	C- 10		E- 9	97780-40525	F- 3
90506-10069	C- 7	91317-06055	C- 3	93102-70167	D- 10	93317-31771	D- 7	95317-08600	D- 10	97801-03008	D- 14
90506-23490	E- 9	91317-06080	C- 3	93104-14059	C- 7	93317-41510	D- 9	95382-06700	B- 14	98502-04008	F- 2
90506-29507	E- 9	91317-10020	C- 14	93104-20068	C- 9	93317-41761	D- 7	95604-06100	F- 4	98502-05016	B- 12
90508-186B1	E- 9	91317-10030	C- 14	93108-43014	D- 10	93317-42060	D- 7	95604-16200	E- 5	98504-05025	F- 4
90508-32012	C- 13	91317-10060	C- 3	93109-17071	D- 7	93320-32403	D- 7	95607-06100	F- 4	98507-04006	B- 14
90508-32535	C- 13	91317-10070	C- 3	93210-07135	B- 8	93340-21505	C- 7	95607-08200	D- 8	98507-04008	B- 13
91314-06016	B- 3	91317-10100	C- 3		B- 9	93399-99931	D- 11	95607-10200	C- 14	98507-04010	B- 13
	B- 7	91401-20012	E- 10		C- 3	93399-99932	D- 11		D- 7		B- 14
	C- 4		E- 9	93210-10096	B- 9	93410-22039	D- 10		D- 8		E- 15
91314-06020	B- 9	91492-10008	B- 14	93210-14359	C- 10	93410-26067	D- 10		E- 9	98507-04012	B- 12
91314-06025	B- 4	91701-06022	E- 9	93210-14369	C- 4	93440-14086	B- 2	95617-08625	B- 2	98507-04014	B- 13
	B- 7	91701-06032	E- 10	93210-15620	E- 11	93440-20088	D- 10	95617-10100	D- 7	98507-04016	F- 4
	D- 5	91817-30011	B- 2	93210-27370	C- 4	93440-31172	C- 9	95617-12100	D- 7	98507-05008	E- 7
	E- 8	92014-05012	B- 10	93210-32172	C- 4	93440-68180	C- 6	95627-08330	D- 8	98507-05012	D- 15
91314-06030	C- 3	92014-06020	C- 5	93210-44545	B- 10	93450-24028	B- 5	95704-06500	E- 13		E- 15
	C- 4	92014-08012	E- 2	93210-48364	C- 7	93604-12037	B- 7		E- 14	98580-05025	F- 4
91314-06035	B- 2	92014-08016	E- 11	93210-48530	E- 5	93604-16092	C- 12	95707-05500	E- 14	98704-04012	E- 8
	C- 4	92014-08025	D- 2	93210-52449	C- 10	93604-20156	C- 12	95707-06500	E- 2	98704-05012	F- 2
	C- 5	92014-08040	D- 11	93210-54452	B- 9	93605-10090	B- 7	95707-08500	D- 11	98707-03020	F- 4
91314-06040	B- 4	92017-06012	D- 14	93210-56459	B- 9	93606-07082	C- 7	95807-06010	D- 2	98707-05035	C- 12
	B- 9		D- 5	93210-57428	E- 5	93608-50158	C- 13		D- 5	98904-06014	B- 15
	C- 5	92017-06016	E- 2	93210-59531	E- 5	94113-1613E	E- 3	95807-06030	E- 8	99001-06600	E- 10
91314-06045	C- 4	92017-06025	F- 2	93210-60426	D- 9	94117-15009	E- 5	95807-08012	D- 15	99001-10600	C- 13
91314-06050	B- 9	92017-08020	B- 15	93210-62446	B- 2	94213-16305	E- 3	95814-06025	C- 6	99009-12400	C- 13
91314-06055	C- 4	92017-10020	B- 15	93210-71360	C- 10	94217-15299	E- 5	95817-06010	B- 11	99009-20400	C- 9
	C- 5	92902-04100	F- 2	93210-92448	B- 2	94313-16175	E- 3	95817-06020	B- 11	99009-25400	C- 9
91314-06060	C- 5	92902-05100	B- 13	93211-44348	D- 10	94317-15180	E- 5	95817-08014	C- 15	99247-00080	D- 2
91314-06065	C- 4	92902-06600	B- 14	93306-20348	E- 5	94430-16565	E- 3	95817-08020	D- 2	99530-08016	B- 8
91314-06100	B- 4	92906-06100	B- 14	93306-20401	C- 9	94445-15607	E- 5	95817-08035	C- 15	99530-10114	C- 4
91314-08016	E- 13	92907-04100	B- 13	93306-20548	C- 10	94580-25066	B- 8	95817-10016	C- 14	99530-10120	C- 5
91314-08020	D- 13		E- 15	93306-20550	C- 9	94591-49098	B- 7	95817-10045	E- 9	99530-14016	C- 3
91314-08025	D- 11	92907-04600	F- 4	93306-20901	C- 10	94701-00218	B- 3	95827-10025	D- 10		
91314-08030	D- 11	92907-05600	D- 15	93306-30317	E- 3	94701-00220	B- 3	97004-06020	E- 9		
91314-08035	B- 15		E- 15		E- 5	95024-06010	D- 11		F- 4		
91314-08040	D- 13		F- 5	93306-30424	C- 9	95024-06012	E- 14	97007-05020	F- 5		
91314-08050	B- 2	92907-06100	E- 2	93306-30525	C- 9	95024-06030	E- 13	97007-06012	E- 2		
91317-05012	E- 12	92907-06600	B- 11	93306-30533	D- 9		E- 14	97007-06025	F- 6		
91317-06010	B- 8	92907-08200	C- 7	93306-30808	B- 5	95027-06008	F- 6	97017-08020	B- 3		
91317-06012	C- 4	92907-08600	B- 2	93306-90602	C- 12	95027-06010	E- 11	97024-06020	C- 13		
	F- 5	92907-08700	D- 10	93306-91201	C- 9		E- 14	97027-06025	C- 8		
	C- 6	92990-10600	D- 10	93310-5720G	C- 6	95027-06016	E- 11	97707-40012	E- 15		
91317-06016	F- 5	93101-14102	C- 4	93311-21044	D- 10	95027-08035	E- 11	97707-40516	F- 3		