

INHALTSVERZEICHNIS

MOTOR

ZYLINDER	B2
KURBELWELLE-KOLBEN	C2
OLPUMPE	D2
EINLASS	E2
VERGASER	F2-G2
AUSLASS	H2
KURBELGEHAUSE	I2
KURBELGEHAUSEDECKEL 1	J2
ANLASSER	K2
KUPPLUNG	L2-B3
GETRIEBE	C3
SCHALTNOCKE-GABEL	D3
SCHALTWELLE-PEDAL	E3

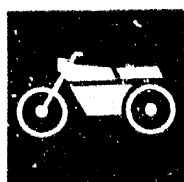
FAHRGESTELL

RAHMEN	F3
KOTFLUGEL	G3
SEITENDECKEL	H3
OLTANK	I3

HINTERRADSCHWINGE	J3
HINTERRADAUFHANGUNG	K3
LENKUNG	L3-B4
VORDERRADGABEL	C4
KRAFSTOFFTANK	D4-E4
SITZ-TRAGER	F4
VORDERRAD	G4
VORDEBRAOBREMSE	H4
HINTERRAD	I4-J4
LENKER-KABEL	K4
HAUPTBREMSZYLINDER	L4
STANDER-FUSSRASTE	B5
MOTORVERKLEIDUNG 1	C5
LICHTMASCHINE	D5
BLINKLEUCHE	E5
METER	F5
SCHEINWERFER	G5
SCHLUSSLEUCHE	H5
LENKERSCHALTER-HEBEL	I5
ELEKTR-AUSRÜSTUNG	J5-K5

VERZEICHNIS

NUMMERNVERZEICHNIS	L16-M16
--------------------------	---------



YAMAHA

TEILE KATALOG

DT50R'91 (3MN2)
W. GERMANY

213MN-332G1

B1



C1

VORWORT

Dieser Ersatzteilkatalog/Micro-Fiche enthält die im Modell DT50R'89(3MN1) verwendeten Teile. Bei einer Ersatzteilbestellung für das Modell DT50R'89(3MN1) sind die in diesem Ersatzteilkatalog/Micro-Fiche aufgeführten Teile-Nummern anzugeben.

1. Modifikationen oder Ergänzungen, die nach der Veröffentlichung dieses Ersatzteilkataloges durchgeführt wurden, werden in der Regel durch Herausgabe eines neuen Ersatzteilkataloges/Micro-Fiche bekanntgegeben.

2. Abkürzungen

Die folgenden Abkürzungen wurden in diesem Ersatzteilkatalog/Micro-Fiche verwendet:

- U.R. Größe (Stärke) und/oder Menge wie erforderlich verwenden
- U.N. Die erforderliche Stückzahl (Menge) verwenden
- A.P. Alternative Teile
- L.M. Herstellung im eigenem Land
- F# Rahmen-Nr. (Zutreffende Fahrgestell-Nr.)

3. Die in diesem Katalog/Micro-Fiche in der Spalte Teile-Nummer mit (*) gekennzeichneten Teile werden nicht von Yamaha hergestellt und geliefert, können jedoch über die Mitsui Organisation bestellt werden.

4. Ersatzteile, die als Einzelteile aus einer kompletten Einheit geliefert werden, sind mit einer Leerstelle und einem Punkt vor der Teilebezeichnung gekennzeichnet.

BEISPIEL BERGASEREINHEIT
 . LEELAUFDÜSE
 . HAUPTDÜSE

5. Stückzahlangabe

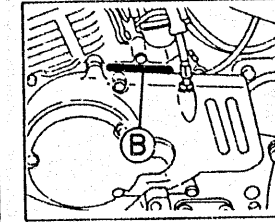
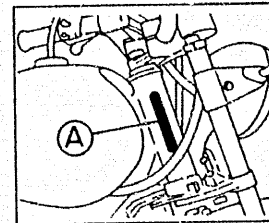
Die rechts neben der Teile-Bezeichnung aufgeführte Zahl gibt die Menge des in der einzelnen Baugruppe verwendeten Teiles an.

BEISPIEL

Teile-Nr.	Bezeichnung	Stck.	Bemerkung
2F5-83310-60	VORDERER BLINKER KOMPL.	2	
115-83311-60	. GLUHLAMPE, blinker	1	
1M1-83309-60	REFLEKTOR	1	

6. Anfängliche Serien-Nr. und Farbcode

(A) Rahmen-Serien-Nr.	3MN 000101 FOLGENDE
(B) Motor-Serien-Nr.	3MN 000101 FOLGENDE



Farbcode	Farbenbezeichnungen	Abkürzungen
	DEEP VIOLET YAMAHA BLACK PURPLISH WHITE	

7. Die zutreffenden Farben der Graphiken, Embleme, Aufkleber usw. sind in der Spalte "Bemerkungen" mit Hilfe von einigen Buchstaben angegeben, die der vollen Farbbezeichnung entnommen wurden.

BEISPIEL

Teile-Nr.	Bezeichnung	Stck.	Bemerkung
2N4-24110-00-X5	KRAFTSTOFFTANK KOMPL.	1	MAXIM RED
3J1-24240-10	. AUFKLEBERSATZ	1	Für MXR

INHALTSVERZEICHNIS

MOTOR

ZYLINDER	B2
KURBELWELLE-KOLBEN	C2
OLPUMPE	D2
EINLASS	E2
VERGASER	F2-G2
AUSLASS	H2
KURBELGEHAUSE	I2
KURBELGEHAUSEDECKEL 1	J2
ANLASSER	K2
KUPPLUNG	L2-B3
GETRIEBE	C3
SCHALTNOCKE-GABEL	D3
SCHALTWELLE-PEDAL	E3

FAHRGESTELL

RAHMEN	F3
KOTFLUGEL	G3
SEITENDECKEL	H3
OLTANK	I3

HINTERRADSCHWINGE	J3
HINTERRADAUFHANGUNG	K3
LENKUNG	L3-B4
VORDERRADGABEL	C4
KRAFSTOFFTANK	D4-E4
SITZ-TRAGER	F4
VORDERRAD	G4
VORDEBRAOBREMSE	H4
HINTERRAD	I4-J4
LENKER-KABEL	K4
HAUPTBREMSZYLINDER	L4
STANDER-FUSSRASTE	B5
MOTORVERMELDUNG 1	C5
LICHTMASCHINE	D5
BLINKLEUCHE	E5
METER	F5
SCHEINWERFER	G5
SCHLUSSLEUCHE	H5
LENKERSCHALTER-HEBEL	I5
ELEKTR-AUSRÜSTUNG	J5-K5

VERZEICHNIS

NUMMERNVERZEICHNIS	L16-M16
--------------------------	---------

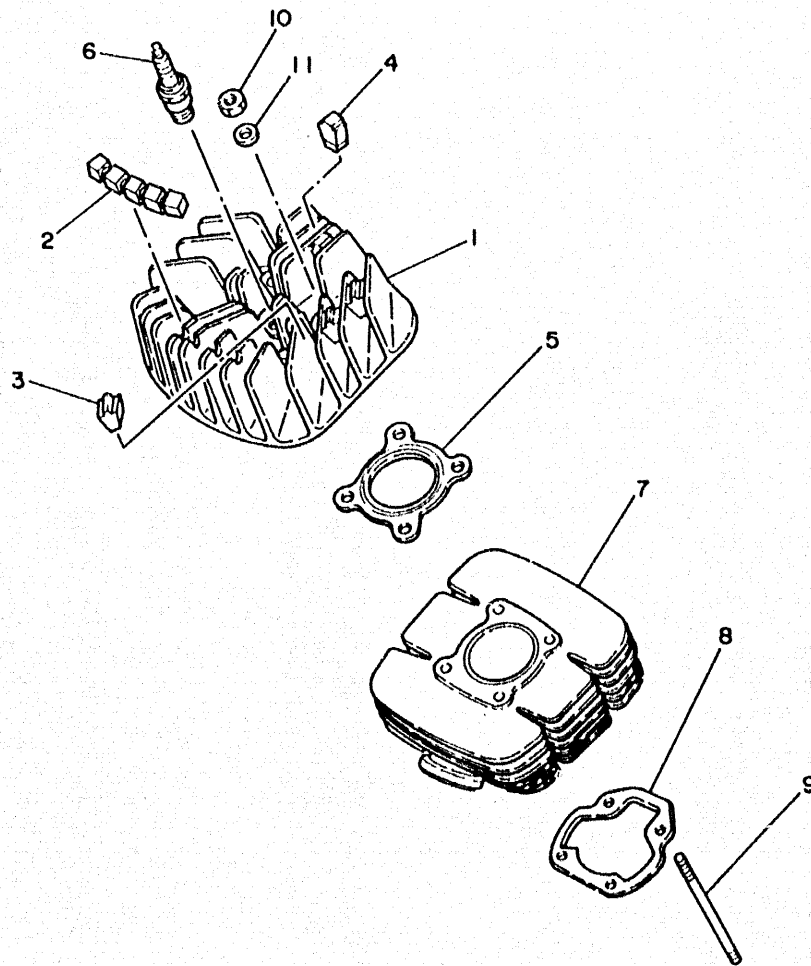


FIG.1 ZYLINDER

REF	TEILE.NR	BEZEICHNUNG	STCK	BEMERKUNG
1	3HL-11111-00	KOPF ZYLINDER	1	
2	5G1-11161-00	ABSORBER 1	1	
3	427-11161-00	ABSORBER 1	3	
4	1T9-11161-00	ABSORBER 1	2	
5	13N-11181-01	DICHTUNG ZYLINDERKOPF	1	
6	94701-00110	ZUNDKERZE	1	
7	3MN-11311-00	ZYLINDER 1	1	
8	353-11351-00	DICHTUNG ZYLINDER	1	
9	90116-06026	STEBBOLZEN	4	
10	95303-06600	NUTTER	4	
11	92901-06200	UNTERLEGESCHEIBE	4	



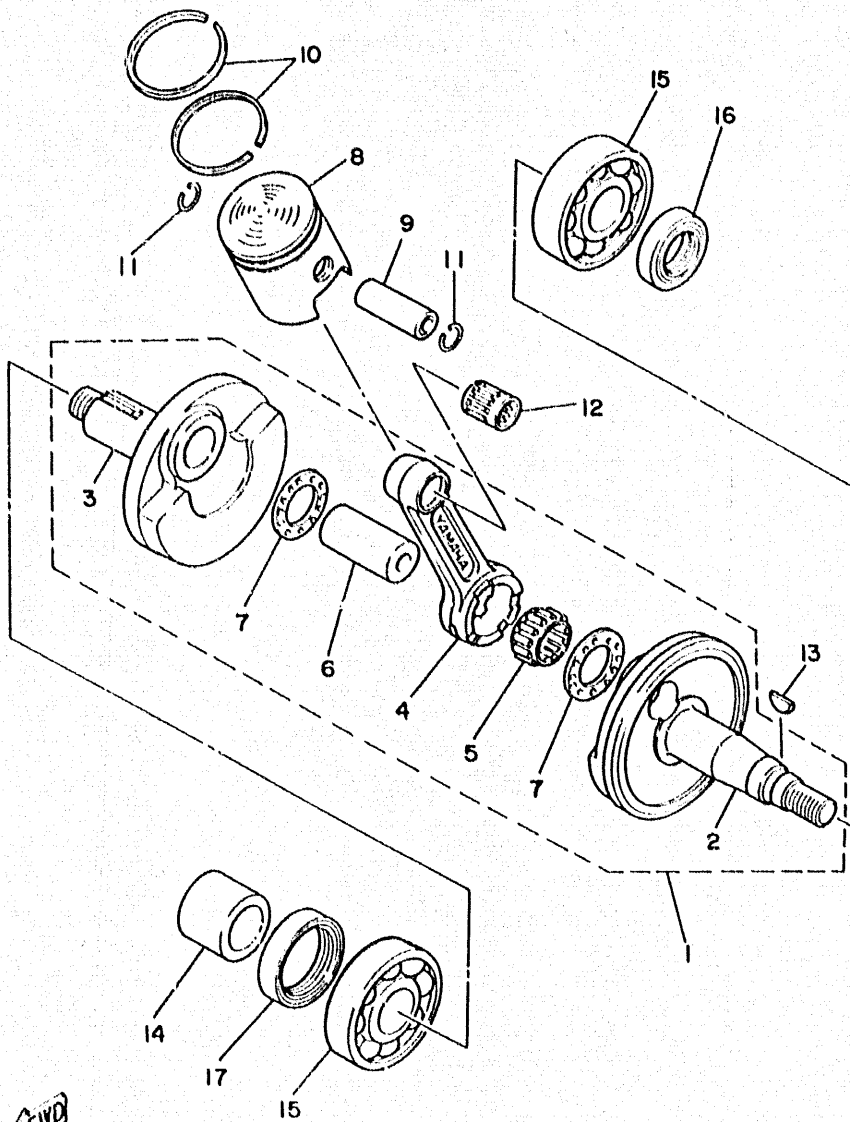


FIG. 2 KURBELWELLE KOLBEN

REF	TEILE.NR	BEZEICHNUNG	STCK	BEMERKUNG
1	4U5-11400-00	KURBELWELLENGRUPPE	1	
2	2U2-11412-00	KURBEL 1	1	
3	2U2-11422-00	KURBEL 2	1	
4	3R1-11651-01	PLEUELSTANGE	1	
5	93310-418T0	LAGER, ZYLINDRISCH	1	
6	257-11681-00	ZAPFEN, KURBEL 1	1	
7	90209-18112	SCHEIBE	2	
8	3T2-11631-01-97	KOLBEN (STANDARD)	1	
	3T2-11635-01	KOLBEN (0.25MM UG)	1	
	3T2-11636-01	KOLBEN (0.50MM UG)	1	
9	517-11633-00	BOLZEN, KOLBEN	1	
10	12Y-11610-00	KOLBENRINGSATZ	1	
	12Y-11610-10	KOLBENRINGSATZ	1	
	12Y-11610-20	KOLBENRINGSATZ	1	
11	93450-13022	SPRENGRING	2	
12	93310-11268	LAGER, ZYLINDRISCH	1	
13	90280-03017	EINLEGE KEIL, WOODRUFF	1	
14	90387-205E9	HULSE	1	
15	93306-20465	LAGER	2	
16	93102-20009	WELLENDICHTRING	1	
17	93103-28011	WELLENDICHTRING	1	
	93103-28126	WELLENDICHTRING	1	



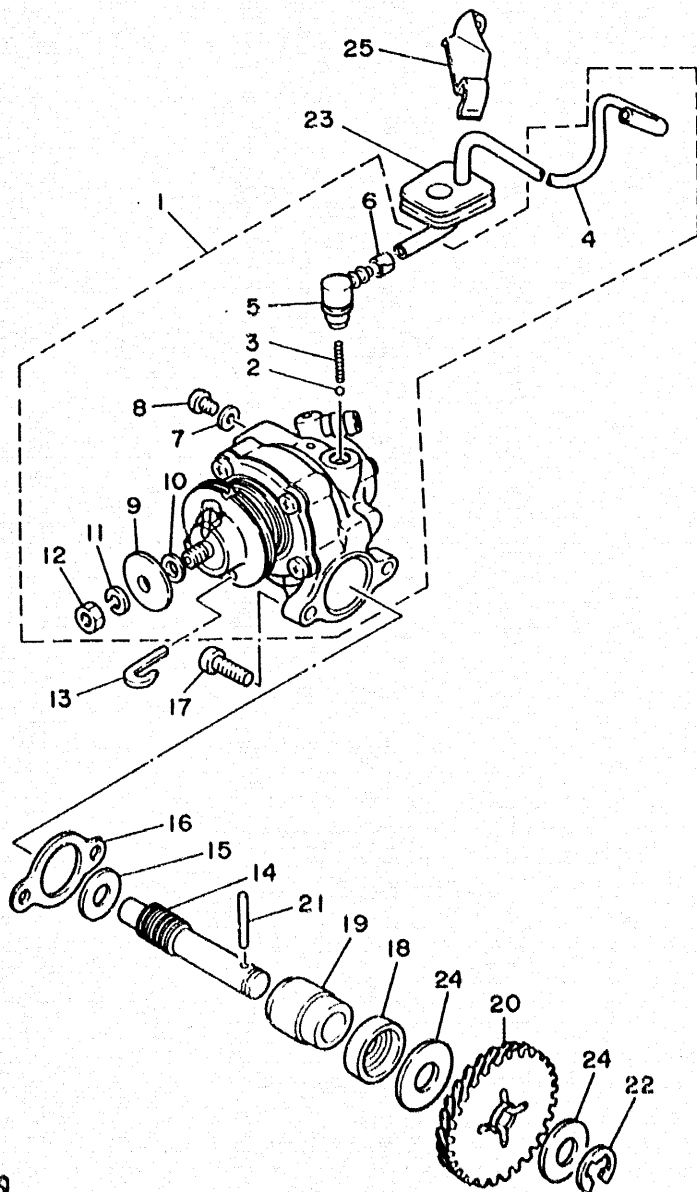
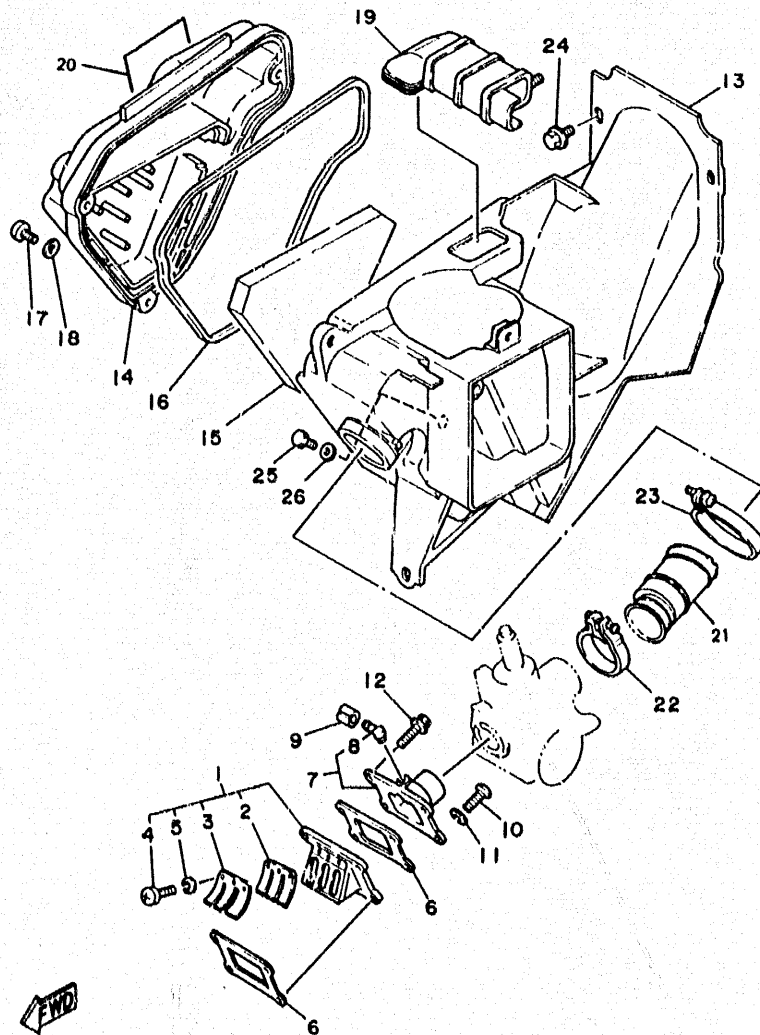


FIG. 3 OLPUMPE

REF	TEILE.NR	BEZEICHNUNG	STCK	BEMERKUNG
1	4U1-13101-01	OLPUMPENEINHEIT	1	
2	93505-32002	KUGEL	1	
3	90501-02217	DRUCKFEDER	1	
4	90445-05278	SCHLAUCH	1	
5	353-13552-01	STUTZEN	1	
6	90468-02033	KLEMME	1	
7	90430-04004	DICHTUNG	1	
8	98901-04008	BLINDSCHRAUBE	1	
9	137-13138-01	EINSTELLPLATTE	1	
10	137-13137-00-10	BEILEGESCHEIBE, VOLLKOLB	1	
11	92901-05100	SCHEIBE	1	
12	95303-05600	MUTTER	1	
13	367-13146-01	DECKEL, EINSTELLRIEMENS	1	
14	2A3-13175-00	SCHNECKENWELLE	1	
15	90201-08624	UNTERLEGSCHIBE	1	
16	8Y0-13116-01	DICHTUNG, PUMPENGEHAUSE	1	
17	98501-05016	ZYLINDERKOPFSCHRAUBE	2	
18	93101-10090	WELLENDICHTRING	1	
19	1E7-13176-00	LAGERSCHALE, SCHNECKENWE	1	
20	353-13178-00	ANTRIEBSRAD, PUMPE	1	
21	93603-22028	PASSSTIFT	1	
22	99001-08600	SPRENGRING	1	
23	248-13174-00	HALTER, OLRORH	1	
24	90201-105J4	UNTERLEGSCHIBE	2	
25	367-13174-00	HALTER, OLRORH	1	

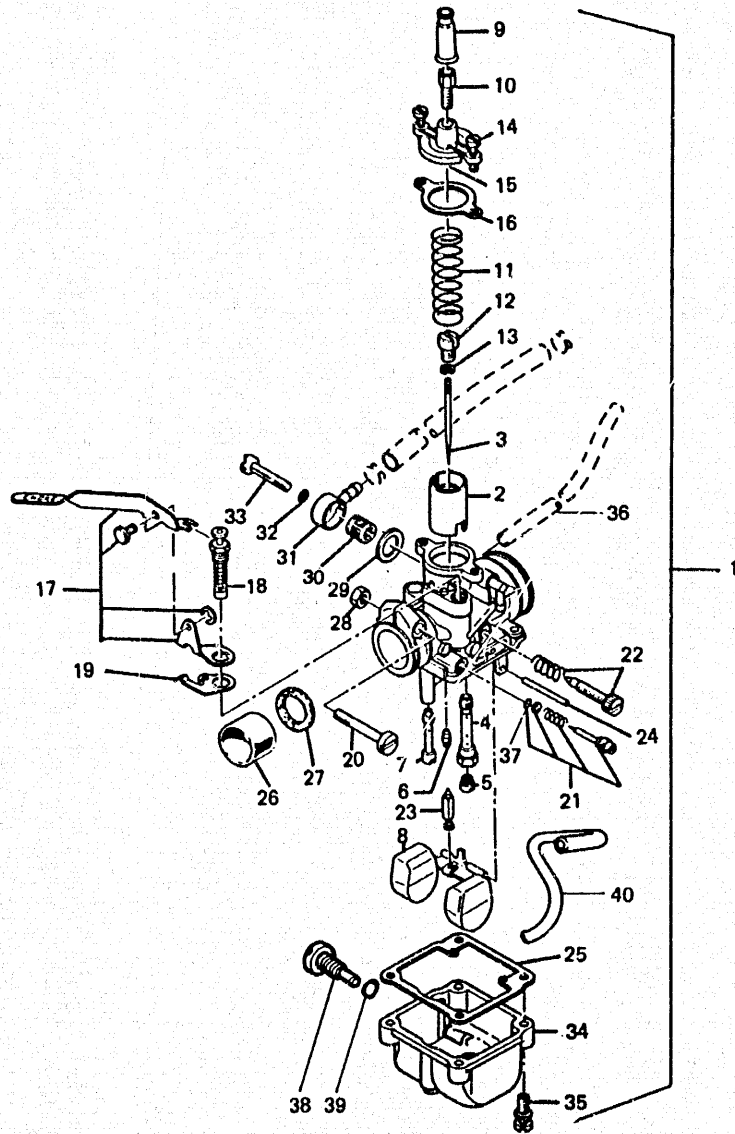


FIG. 4 EINLASS



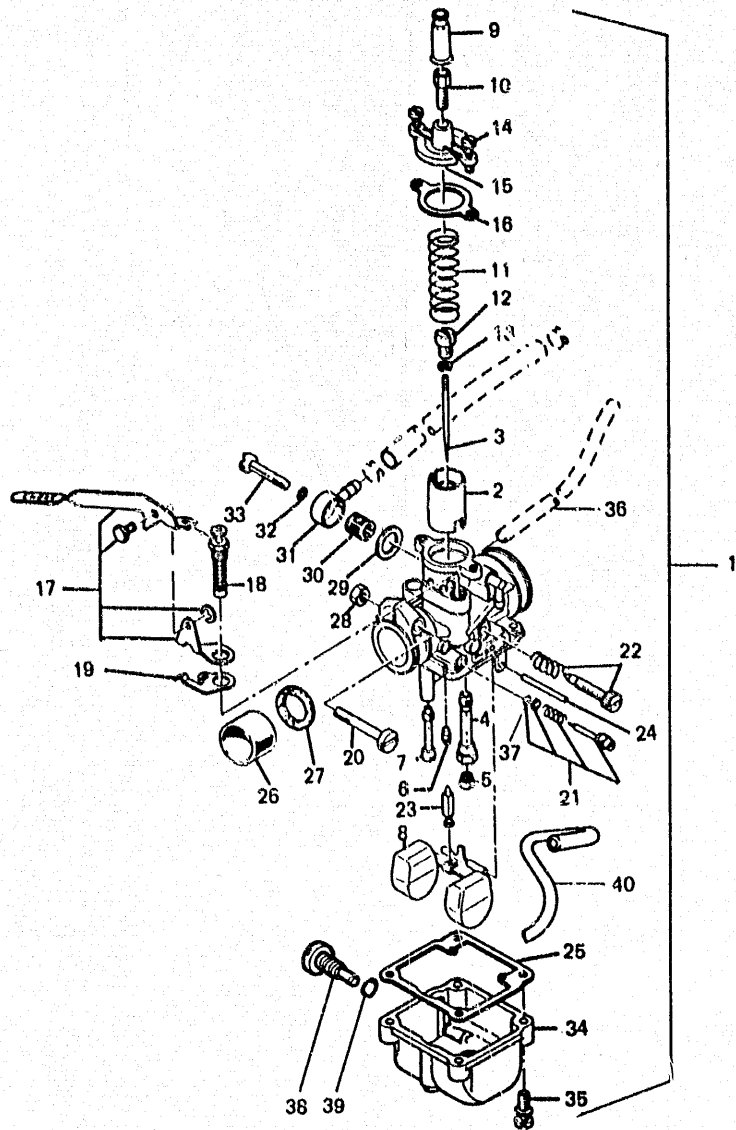
REF	TEILE.NR	BEZEICHNUNG	STCK	BEMERKUNG
1	5G1-13610-00	ZUNGENVENTILEINHEIT	1	
2	2A3-13613-00	ZUNGE, VENTIL	1	
3	5G1-13616-00	ANSCHLAG, ZUNGENVENTIL	1	
4	98501-03008	ZYLINDERKOPFSCHRAUBE	3	
5	92990-03100	SCHEIBE	3	
6	353-13621-00	DICHTUNG, VENTILSITZ	2	
7	3MN-13565-00	VERBINDUNG, VERGASER	1	
8	278-13552-02	STUTZEN	1	
9	90468-02033	KLEMME	1	
10	92501-06025	ZYLINDERKOPFSCHRAUBE	4	
11	92990-06100	SCHEIBE	4	
12	90109-06614	SCHRAUBE	2	
13	3HL-14420-00	LUFTFILTEREINHEIT 2	1	
14	3MP-14412-00	KAPPE, FILTERGEHAUSE	1	
15	3T2-14451-00	ELEMENT, LUFTFILTER	1	
16	5T8-14452-00	DICHTUNG	1	
17	92506-06016	ZYLINDERKOPFSCHRAUBE	3	
18	92906-06600	SCHEIBE	3	
19	3T2-14437-00	KANAL	1	
20	3MN-E441K-00	EMBLEM	1	
21	3MP-E4453-00	VERBINDUNG, LUFTFILTER 1	1	
22	90460-33087	SCHLAUCHSCHELLE	1	
23	90460-51059	SCHLAUCHSCHELLE	1	
24	97313-08016	SCHRAUBE, MIT SCHEIBE	5	
25	97313-08016	SCHRAUBE	1	
26	92901-06600	SCHEIBE	1	

FIG. 5 VERGASER



REF	TEILE.NR	BEZEICHNUNG	STCK	BEMERKUNG
1	3MN-E4301-01	VERGASEREINHEIT	1	
2	3HL-E4112-00	VENTIL, DROSSEL	1	
3	3MR-E4116-10	NADEL	1	
4	3MR-E4341-10	HAUPTZERSTAUBER	1	
5	3MN-E4343-00	HAUPTDUSE	1	
6	3MN-E4142-00	DUSE, LEERLAUF	1	
7	3HL-E4312-00	VENTIL, DROSSEL	1	
8	3HL-E4385-00	SCHWIMMER	1	
9	3HL-E4169-00	KAPPE	1	
10	3HL-E4106-00	EINSTELLSCHRAUBENSATZ	1	
11	3HL-E4331-00	FEDER, DROSSELVENTIL	1	
12	3HL-E4136-00	SITZ, FEDER	1	
13	3HL-E4137-00	KLEMME	1	
14	3HL-E4444-00	DISTANZHULSE	2	
15	3HL-E4168-00	KAPPE, MISCHKAMMER	1	
16	3HL-E4126-00	DICHTUNG	1	INS O.RING SATZ
17	3HL-E4375-00	HEBEL, ANLASSER	1	
18	3HL-E4371-00	VOLLKOLBEN, ANLASSER	1	
19	3HL-E4377-00	ANSCHLAG	1	
20	3HL-E4125-00	SCHRAUBE	1	
21	3MP-E4104-00	LUFTREGULIERSCHRAUBENSATZ	1	
22	3HL-E4103-00	DROSSELSCHRAUBENSATZ	1	
23	3HL-E4392-00	VENTIL, NADEL	1	
24	3HL-E4386-00	STIFT, SCHWIMMER	1	
25	3HL-E4384-00	DICHTUNG, SCHWIMMERKAMME	1	INS O.RING SATZ
26	3HL-E4156-00	DICHTUNG, ISOLATOR	1	
27	3HL-E4126-00	DICHTUNG	1	INS O.RING SATZ
28	95701-06500	FLANSCHMUTTER	1	

FIG.5 VERGASER



REF	TEILE.NR	BEZEICHNUNG	STCK	BEMERKUNG
29	3HL-F4348-00	DICHTUNG, HOHLSCHRAUBE 2	1	INS O.RING SATZ
30	3HL-F4501-00	BENZIN FILTER	1	
31	3HL-F4341-00	HOHLSCHRAUBENVERBINDUNG	1	
32	3HL-F4345-00	HOHLSCHRAUBE 2	1	INS O.RING SATZ
33	3HL-F4146-00	MUTTER, KRAFTSTOFFTANK	1	1
34	3MN-E4181-10	GEHAUSE, SCHWIMMERKAMMER	1	
35	98580-04016	ZYLINDERKOPFSCHRAUBE	4	
36	3HL-E4349-00	ROHR	1	
37	3HL-F4345-00	HOHLSCHRAUBE 2	1	INS O.RING SATZ
38	3MN-E4383-00	REINIGUNGSSCHRAUBE	1	
39	3MN-E4198-00	DICHTUNG	1	
40	3MN-E443E-00	SCLAUCH	1	
	3HL-W0005-00	O-RING-SATZ	1	

(REP:16/25/27/29/32/37)

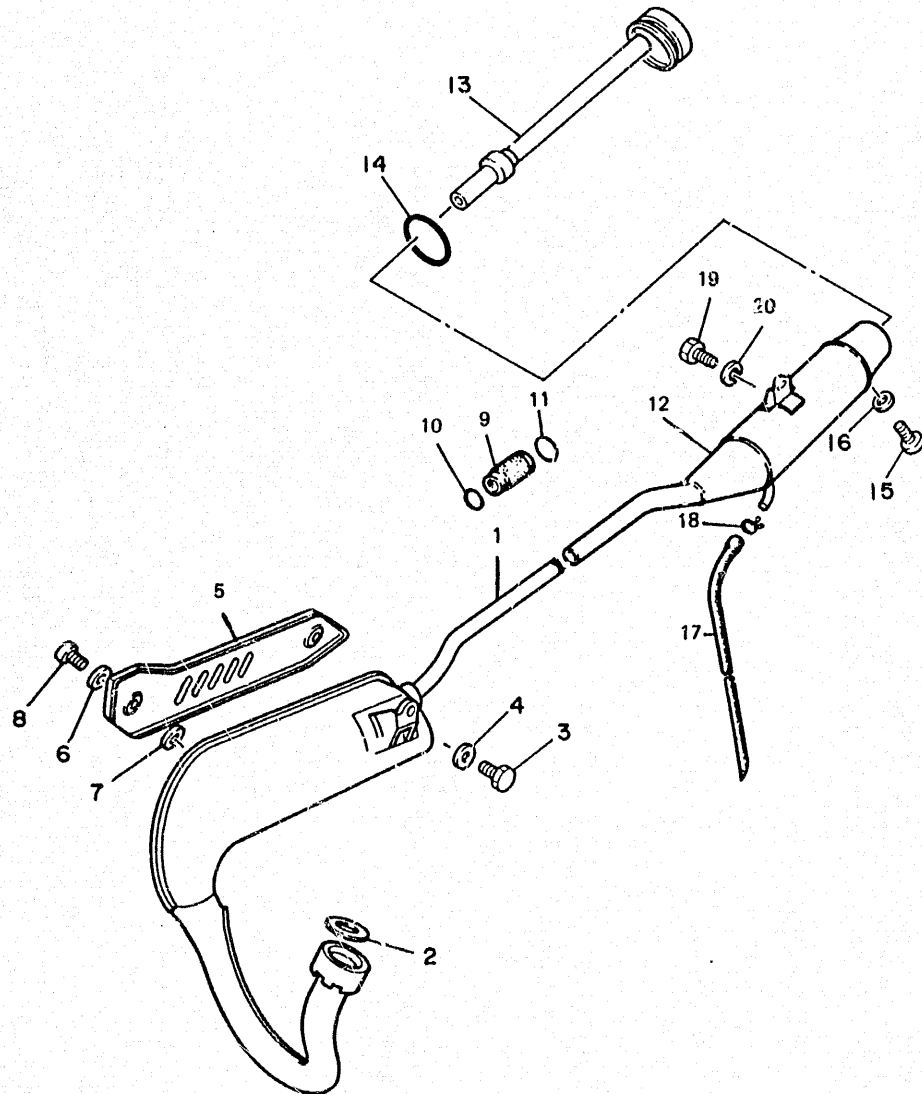


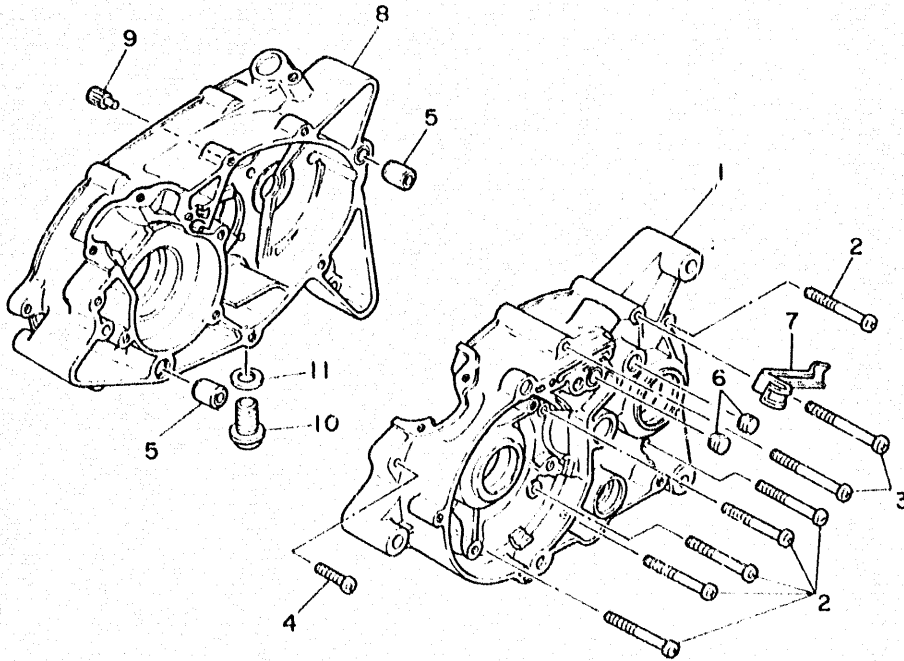
FIG. 6 AUSLASS

REF	TEILE.NR	BEZEICHNUNG	STCK	BEMERKUNG
1	3MN-E4610-00-11	AUSPUFFROHREINHEIT 1	1	
2	132-14613-00	DICHTUNG, AUSPUFFROHR	1	
3	97006-08020	SCHRAUBE	1	
4	92906-08600	SCHEIBE	1	
5	3HL-E4718-00-11	SCHUTZ, SCHALLDAMPFER 1	1	
6	90202-06010	UNTERLEGSCHIBE	2	
7	90202-05005	UNTERLEGSCHIBE	2	
8	98906-06010	BLINDSCHRAUBE	2	
9	3MP-E4615-00	VERBINDUNG, AUSPUFF 1	1	
10	3MP-E4683-00	FEDER, HAKEN	1	
11	3MP-E4683-10	FEDER, HAKEN	1	
12	3MN-E4753-00-11	SCHALLDAMPFER, AUSPUFF	1	
13	1NN-14752-00	ROHR, AUSLASS	1	
14	93210-40407	O-RING	1	
15	92506-06010	ZYLINDERKOPFSCHRAUBE	1	
16	92906-06600	SCHEIBE	1	
17	90445-117E0	SCHLAUCH	1	
18	90467-10008	KLEMME	1	
20	97313-08016	SCHRAUBE	1	
21	92990-08100	SCHEIBE	1	



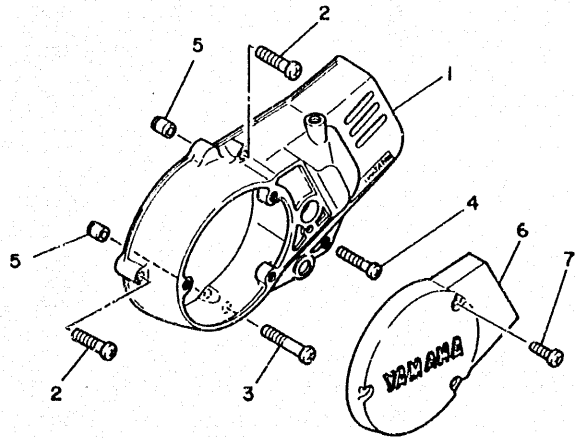
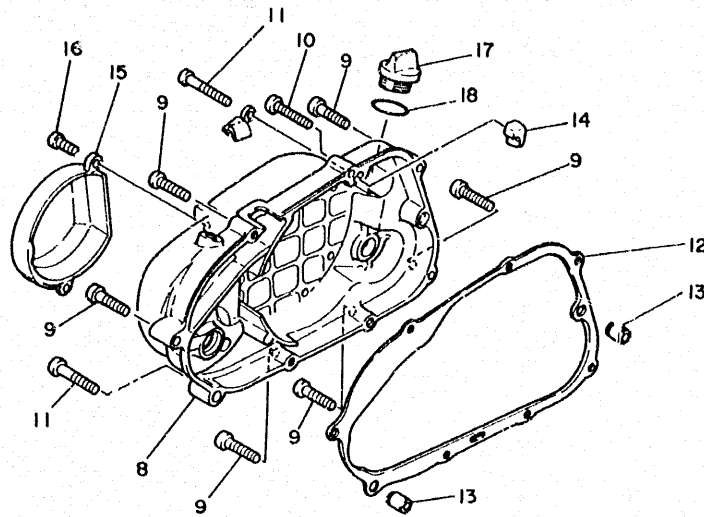
FIG. 7 KURBELGEHAUSE

REF	TEILE.NR	BEZEICHNUNG	STCK	BEMERKUNG
1	353-15111-01	KURBELGEHAUSE 1	1	
2	92501-06050	ZYLINDERKOPFSCHRAUBE	8	
3	92501-06055	ZYLINDERKOPFSCHRAUBE	2	
4	92501-06025	ZYLINDERKOPFSCHRAUBE	1	
5	99510-12016	PASSTIFT	2	
6	90334-12009	ZYLINDERSTOPFEN	2	
7	3T2-15484-01	KLEMME 2	1	
8	353-15121-03	KURBELGEHAUSE 2	1	
9	492-15387-00	ANSCHLAG	1	
10	90340-12005	VERSCHLUSSSCHRAUBE, ZYL.	1	
11	90430-12038	DICHTUNG	1	



5M6310-3080

FIG. 8 KURBELGEHAUSEDECKEL



REF	TEILE.NR	BEZEICHNUNG	STCK	BEMERKUNG
1	5T8-E5411-01	DECKEL, KURBELGEHAUSE	1	1
2	92516-06030	ZYLINDERKOPFSCHRAUBE	2	
3	92506-06040	ZYLINDERKOPFSCHRAUBE	1	
4	92506-06045	ZYLINDERKOPFSCHRAUBE	1	
5	99530-10014	PASSTIFT	2	
6	5T8-E5415-00	DECKEL, LICHTMASCHINE	1	
7	92506-06020	ZYLINDERKOPFSCHRAUBE	3	
8	4U7-15421-00	DECKEL, KURBELGEHAUSE	2	1
9	92516-06030	ZYLINDERKOPFSCHRAUBE	6	
10	92506-06035	ZYLINDERKOPFSCHRAUBE	1	
11	92506-06040	ZYLINDERKOPFSCHRAUBE	2	
12	353-15451-00	DICHTUNG, KURBELGEHAUSED	1	
13	99530-10014	PASSTIFT	2	
14	353-15437-02	OLABSTREIFER	1	
15	4U7-15416-00	DECKEL, OLPUMPE	1	
16	92506-06016	ZYLINDERKOPFSCHRAUBE	2	
17	353-15362-00	OLSTANDSCHRAUBE	1	
18	93210-21190	O-RING	1	



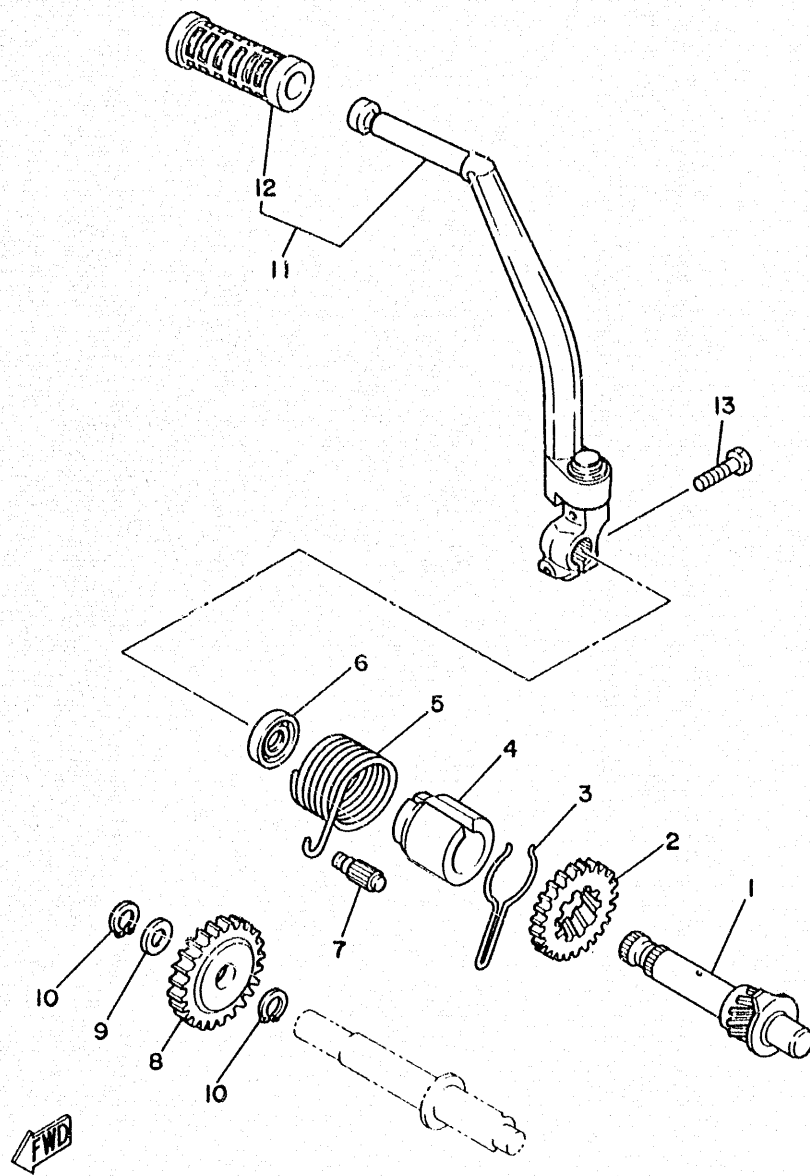


FIG. 9 ANLASSER

REF	TEILE.NR	BEZEICHNUNG	STCK	BEMERKUNG
1	2AL-15660-00	KICKSTARTERWELLE	1	
2	353-15641-00	ZAHNRAD, KICKSTARTER	1	
3	90468-26038	KLEMME	1	
4	4U1-15664-00	FUHRUNG, FEDER	1	
5	90508-26136	ZUGFEDER	1	
6	93109-15001	WELLENDICHTRING	1	
7	248-15668-00	ANSCHLAG	1	
8	353-15651-00	ZWISCHENRAD, KICKSTARTER	1	
9	90201-12166	UNTERLEGSCHIBE	1	
10	99009-12400	SPRENGRING	2	
11	2UM-E5620-00	KICKSTARTERKURBEL	1	
12	5T8-E5618-00	DECKEL, KIPPSTARTERHEBEL	1	
13	97016-06025	SCHRAUBE	1	

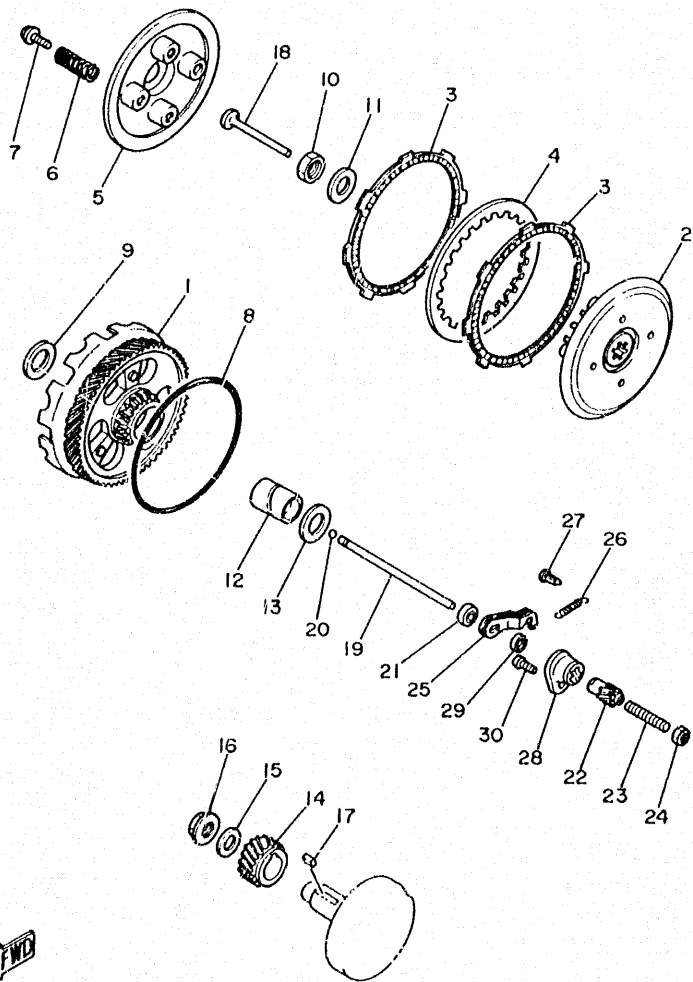


FIG.10 KUPPLUNG

REF	TEILE.NR	BEZEICHNUNG	STCK	BEMERKUNG
1	5L3-16150-00	PRIMARABTRIEBSRAD KOMPL.	1	
2	257-16371-01	KUPPLUNGSNABE	1	
3	131-16321-00	REIBSCHEIBE	2	
4	131-16324-00	KUPPLUNGSSCHEIBE 1	1	
5	257-16351-00	DRUCKPLATTE 1	1	
6	90501-20122	DRUCKFEDER	4	
7	90119-05001	SCHRAUBE, MIT SCHEIBE	4	
8	93210-99103	O-RING	1	
9	122-16164-00	DRUCKPLATTE 2	1	
10	90170-12060	MUTTER	1	
11	90208-12015	TELLERFEDER	1	
12	90560-17123	ABSTANDHALTER	1	
13	122-16164-00	DRUCKPLATTE 2	1	
14	353-16111-01	ZAHNRAD, PRIMARANTRIEB	1	
15	90208-12015	TELLERFEDER	1	
16	90179-12244	MUTTER	1	
17	90282-05005	PASSFEDER	1	
18	137-16356-00	SCHUBSTANGE 1	1	
19	353-16357-00	SCHUBSTANGE 2	1	
20	93503-16010	KUGEL	1	
21	93102-04382	WELLENDICHTRING	1	
22	241-16341-01	DRUCKSCHEIBE	1	
23	90113-06013	STELLSCHRAUBE	1	
24	95303-06700	MUTTER	1	
25	451-16342-00	DRUCKHEBEL	1	
26	90506-07066	ZUGFEDER	1	
27	132-16346-00	HAKEN, FEDER	1	
28	353-16396-00	GEHAUSE, SCHUBSPINDEL	1	

INHALTSVERZEICHNIS

MOTOR

ZYLINDER	B2
KURBELWELLE-KOLBEN	C2
OLPUMPE	D2
FINLASS	E2
VERGASER	F2-G2
AUSLASS	H2
KURBELGEHAUSE	I2
KURBELGEHAUSEDECKEL 1	J2
ANLASSER	K2
KUPPLUNG	L2-B3
GETRIEBE	C3
SCHALTNOCKE-GABEL	D3
SCHALTWELLE-PEDAL	E3

FAHRGESTELL

RAHMEN	F3
KOTFLUGEL	G3
SEITENDECKEL	H3
OLTANK	I3

HINTERRADSCHWINGE	J3
HINTERRADAUFHANGUNG	K3
LENKUNG	L3-B4
VORDERRADGABEL	C4
KRAFTSTOFFTANK	D4-E4
SITZ-TRAGER	F4
VORDERRAD	G4
VORDEBRAOBREMSE	H4
HINTERRAD	I4-J4
LENKER-KABEL	K4
HAUPTBREMSZYLINDER	L4
STANDER-FUSSRASTE	B5
MOTORVERKLEIDUNG 1	C5
LICHTMASCHINE	D5
BLINKLEUCHE	E5
METER	F5
SCHEINWERFER	G5
SCHLUSSLEUCHE	H5
LENKERSCHALTER-HEBEL	I5
ELEKTR-AUSRÜSTUNG	J5-K5

VERZEICHNIS

NUMMERNVERZEICHNIS	L16-M16
--------------------------	---------

INHALTSVERZEICHNIS

MOTOR

ZYLINDER	B2
KURBELWELLE-KOLBEN	C2
OLPUMPE	D2
EINLASS	E2
VERGASER	F2-G2
AUSLASS	H2
KURBELGEHAUSE	I2
KURBELGEHAUSEDECKEL 1	J2
ANLASSER	K2
KUPPLUNG	L2-B3
GETRIEBE	C3
SCHALTNOCKE-GABEL	D3
SCHALTWELLE-PEDAL	E3

FAHRGESTELL

RAHMEN	F3
KOTFLUGEL	G3
SEITENDECKEL	H3
OLTANK	I3

HINTERRADSCHWINGE	J3
HINTERRADAUFHANGUNG	K3
LENKUNG	L3-B4
VORDERRADGABEL	C4
KRAFSTOFFTANK	D4-E4
SITZ-TRAGER	F4
VORDERRAD	G4
VORDEBRAOBREMSE	H4
HINTERRAD	I4-J4
LENKER-KABEL	K4
HAUPTBREMSZYLINDER	L4
STANDER-FUSSRASTE	B5
MOTORVERKLEIDUNG 1	C5
LICHTMASCHINE	D5
BLINKLEUCHE	E5
METER	F5
SCHEINWERFER	G5
SCHLUSSLEUCHE	H5
LENKERSCHALTER-HEBEL	I5
ELEKTR-AUSRÜSTUNG	J5-K5

VERZEICHNIS

NUMMERNVERZEICHNIS	L16-M16
--------------------------	---------

FIG. 10 KUPPLUNG

REF	TEILE.NR	BEZEICHNUNG	STCK	BEMERKUNG
29	93104-10085	WELLENDICHTRING	1	
30	92501-06014	ZYLINDERKOPFSCHRAUBE	1	

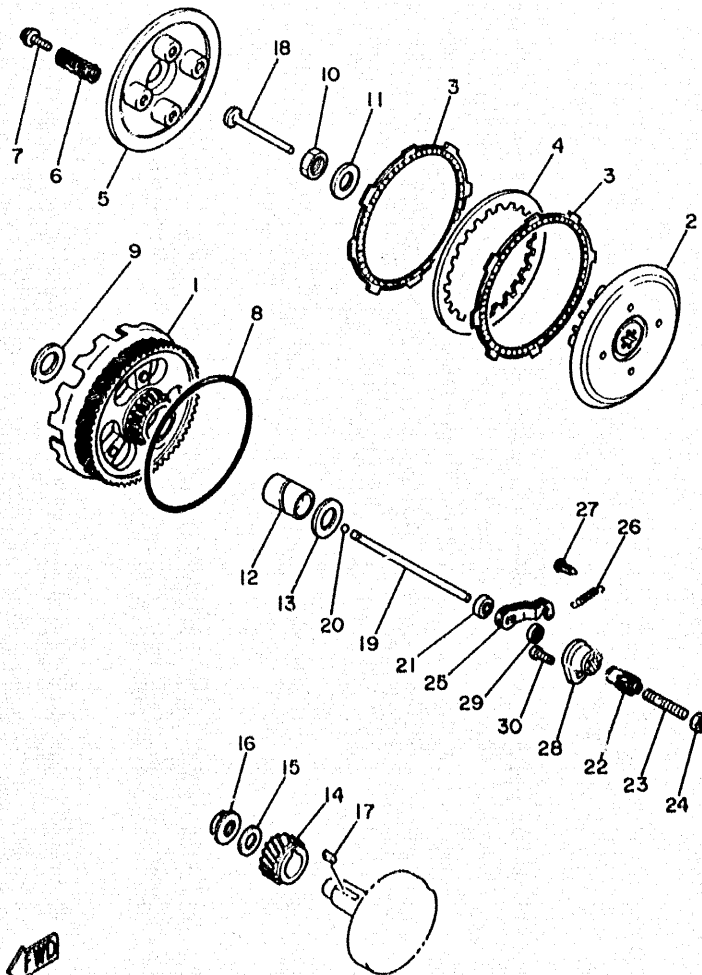
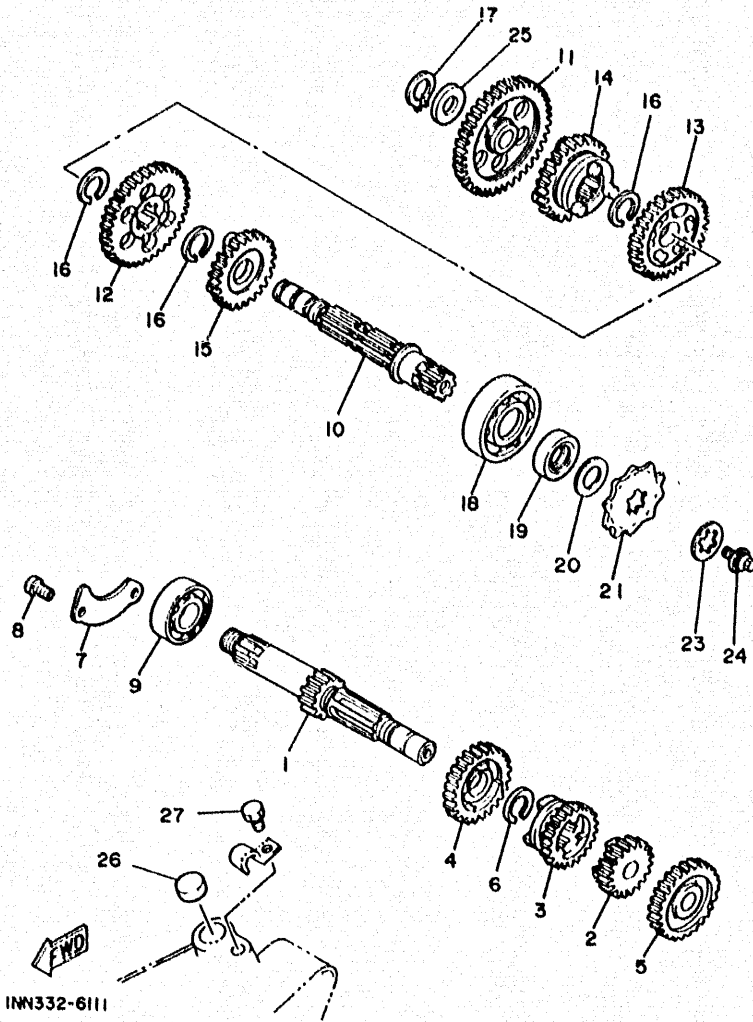
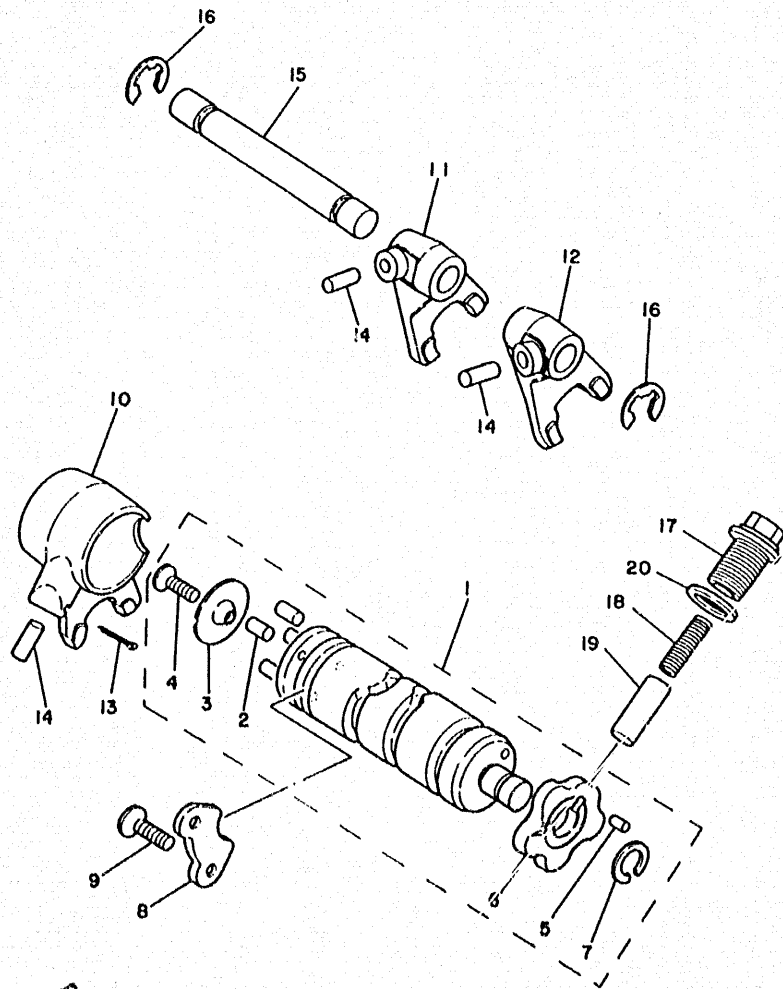


FIG. 11 GETRIEBE



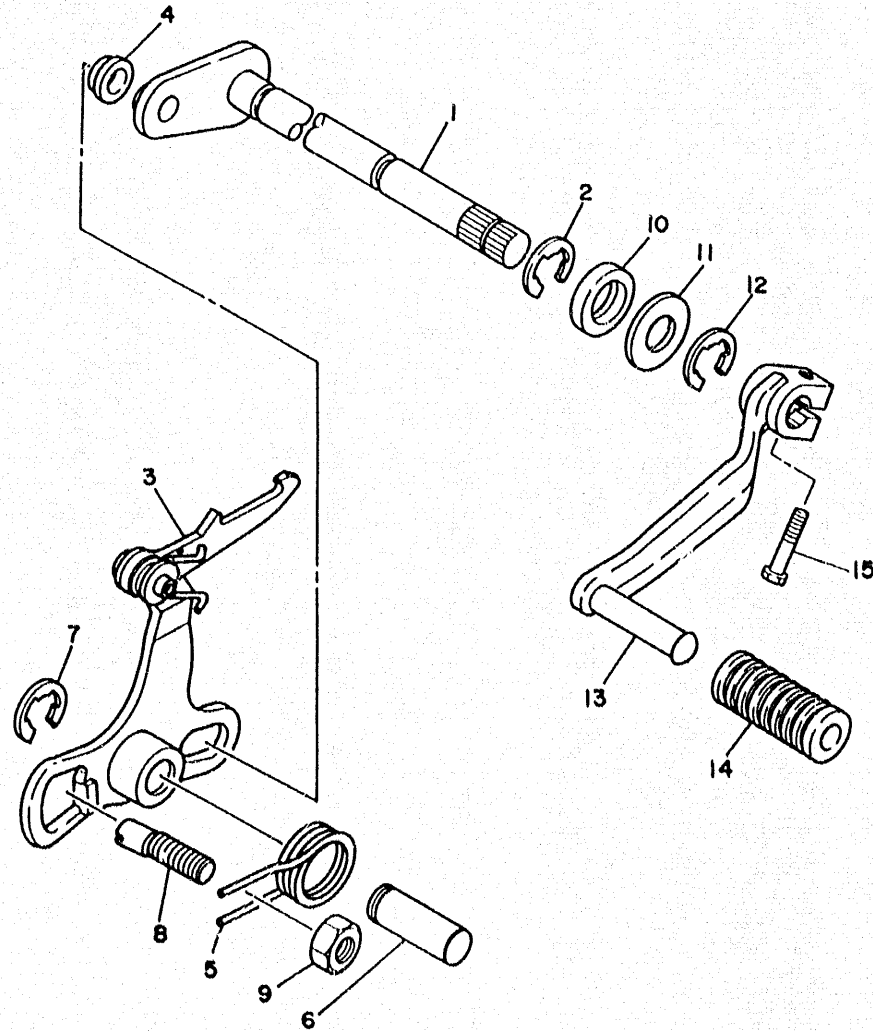
REF	TEILE.NR	BEZEICHNUNG	STCK	BEMERKUNG
1	353-17411-10	HAUPTWELLE	1	
2	353-17121-11	ZAHNRAD, 2. RITZEL	1	
3	353-17131-10	ZAHNRAD, 3. RITZEL	1	
4	353-17141-72	ZAHNRAD, 4. RITZEL	1	
5	353-17151-70	ZAHNRAD, 5. RITZEL	1	
6	93440-16089	SPRENGRING	1	
7	353-17471-00	PLATTF, DECKEL	1	
8	92501-06012	ZYLINDERKOPFSCHRAUBE	2	
9	93306-20333	LAGER	1	
10	20M-17421-00	ANTRIEBSWELLE	1	
11	353-17211-01	ZAHNRAD, 1. GANG	1	
12	353-17221-00	ZAHNRAD, 2. GANG	1	
13	353-17231-00	ZAHNRAD, 3. GANG	1	
14	353-17241-70	ZAHNRAD, 4. GANG	1	
15	353-17251-70	ZAHNRAD, 5. GANG	1	
16	93440-16089	SPRENGRING	3	
17	99009-13400	SPRENGRING	1	
18	93306-30301	LAGER	1	
19	93102-17187	WELLENDICHTRING	1	
20	90209-13817	SCHEIBE	1	
21	1NN-E7461-00	ANTRIEBSKETTENRAD	1	
23	90209-13185	SCHEIBE	1	
24	99999-01529		1	
25	257-17219-00	BEILEGSCHIEBE	1	
26	90338-16029	VERSCHLUSS	1	
27	97011-06010	SCHRAUBE	1	

FIG.12 SCHALTNOCCKE GABEL



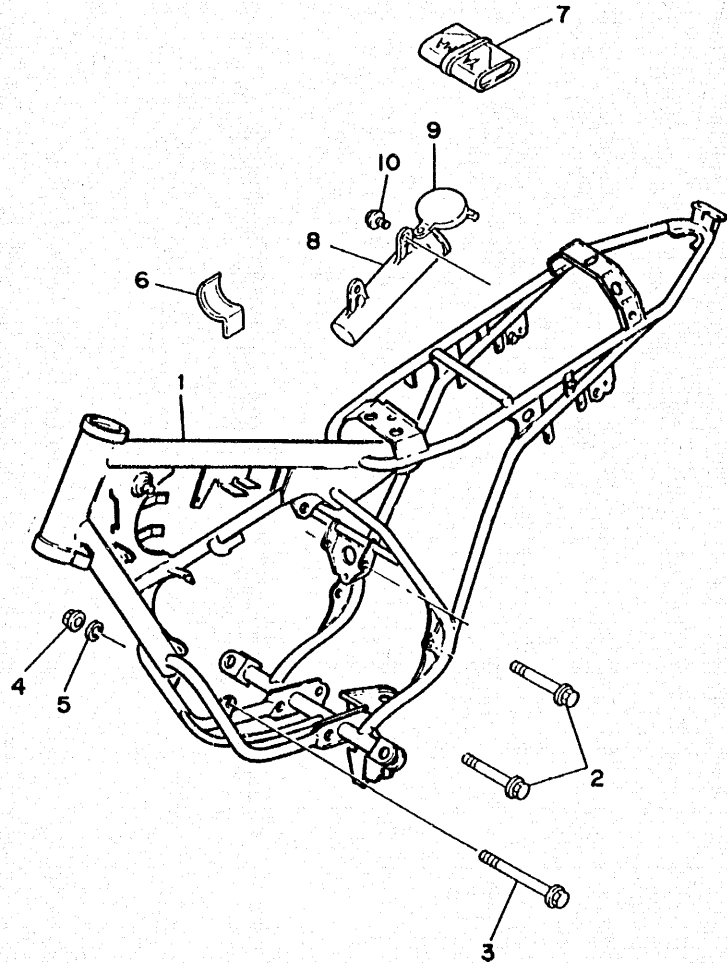
REF	TEILE.NR	BEZEICHNUNG	STCK	BEMERKUNG
1	4U5-18540-00	SCHALTNOCCKENWEIMHEIT	1	
2	93604-10011	PASSSTIFT	4	
3	214-18561-00	SEITENPLATZE 1	1	
4	98701-05012	SENKSCBRAUBE	1	
5	93604-08071	PASSSTIFT	1	
6	353-18141-01	PLATTE, ANSCHLAG	1	
7	93440-12026	SPRENGRING	1	
8	353-18562-00	ANSCHLAGPLATTE 2	1	
9	92701-06012	SENKSCBRAUBE	2	
10	353-18511-01	SCHALTGABEL 1	1	
11	353-18512-01	SCHALTGABEL 2	1	
12	353-18513-01	SCHALTGABEL 3	1	
13	91401-25020	SPLINT	1	
14	93606-14081	PASSSTIFT	3	
15	214-18531-00	STANGE, SCHALTGABELFUHRU	1	
16	99001-10600	SPRENGRING	2	
17	90109-14485	SCHRAUBE	1	
18	90501-09292	DRUCKFEDER	1	
19	353-18547-00	NOCCKENANSCHLAG	1	
20	137-15353-00	DICHTUNG, ABLASSSCHRAUBE	1	

FIG.13 SCHALTWELLE PEDAL



REF	TEILE.NR	BEZEICHNUNG	STCK	BEMERKUNG
1	2AL-18101-00	SCHALTWELLENEINHEIT	1	
2	99001-10600	SPRENGRING	1	
3	353-18120-00	SCHALTHEBELEINHEIT	1	
4	214-18178-00	ROLLE, SCHALTHEBEL	1	
5	90508-32054	ZUGFEDER	1	
6	367-18197-00	WELLE	1	
7	99001-10600	SPRENGRING	1	
8	90149-08094	SCHRAUBE	1	
9	95303-08600	MUTTER	1	
10	93102-12106	WELLENDICHTRING	1	
11	90201-12575	UNTERLEGSCHIBE	1	
12	99001-10600	SPRENGRING	1	
13	5T8-E8111-00	SCHALTPEDAL	1	
14	5T8-E8113-00	DECKEL, SCHALTPEDAL	1	
15	97016-06020	SCHRAUBE	1	

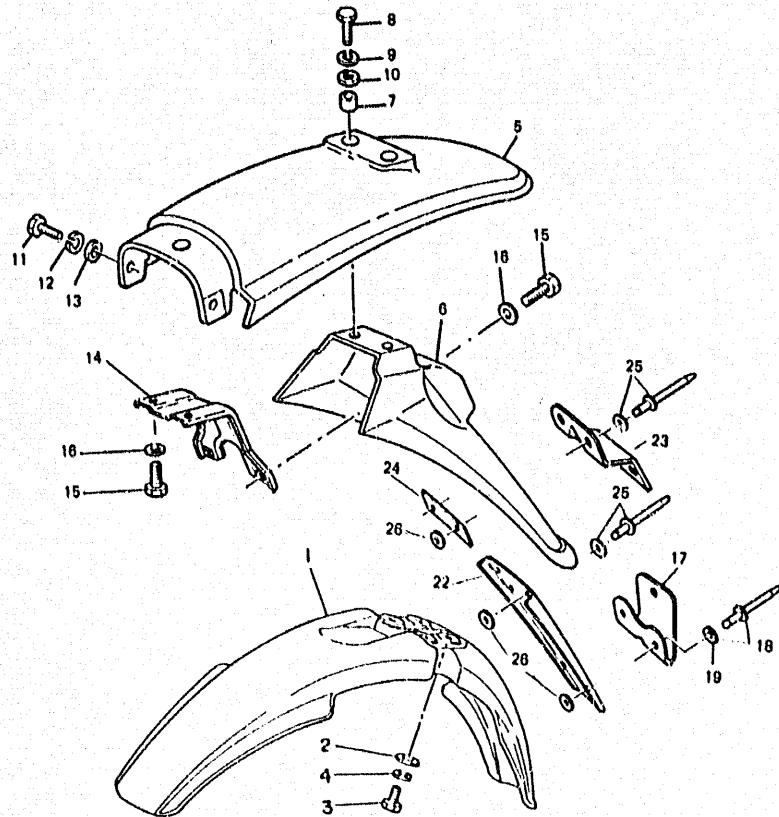
FIG.14 RAHMEN



REF	TEILE.NR	BEZEICHNUNG	STCK	BEMERKUNG
1	3MP-F1110-00-13	RAHMEN FARAWAY BLUE	1	UR YAMAHA BLACK
	3MP-F1110-00-14	RAHMEN VIOLET	1	UR DEEP VIOLET
	3MP-F1110-00-12	RAHMEN WHITE	1	UR PURPLISH WHITE
2	95811-08090	FLANSCHSCHRAUBE	2	
3	95811-08120	FLANSCHSCHRAUBE	1	
4	95701-08500	FLANSCHMUTTER	2	
5	92901-08600	SCHEIBE	2	
6	90465-05052	SCHELLE	1	
7	54Y-F8100-00	WERKZEUGSATZ	1	
8	17W-28173-00	WERKZEUGKASTEN	1	
9	17W-28185-00	DECKEL	1	
10	90119-06056	SCHRAUBE, MIT SCHEIBE	2	



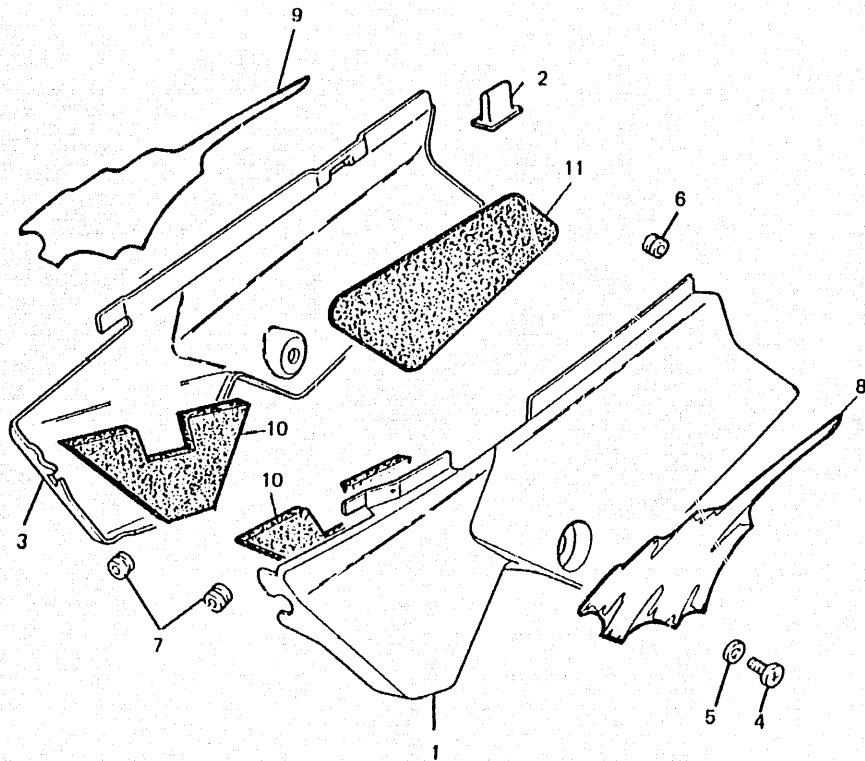
FIG. 15 KOTFLUGEL



REF	TEILE.NR	BEZEICHNUNG	STCK	BEMERKUNG
1	5T8-F1511-60	KOTFLUGEL, VORNE WHITE	1	UR PURPLISH WHITE
	5T8-F1511-30	KOTFLUGEL, VORNE BLACK	1	UR YAMAHA BLACK
	5T8-F1511-70	KOTFLUGEL, VORNE VIOLET	1	UR DEEP VIOLET
2	90201-06067	UNTERLEGSCHIBE	4	
3	97001-06020	SCHRAUBU	4	
4	92990-06100	SCHEIBE	4	
5	3HL-F1611-40	KOTFLUGEL, HINTERRAD W.	1	UR PURPLISH WHITE
	3HL-F1611-10	KOTFLUGEL, HINTERRAD B.	1	UR YAMAHA BLACK
	3HL-F1611-50	KOTFLUGEL, HINTERRAD V.	1	UR DEEP VIOLET
6	3MR-F1621-00	KLAPPE	1	
7	90387-064T3	HULSE	2	
8	97026-06014	SCHRAUBE	3	
9	92906-06100	SCHEIBE	3	
10	92906-06600	SCHEIBE	3	
11	92506-06014	ZYLINDERKOPFSCHRAUBE	2	
12	92906-06100	SCHEIBE	2	
13	92906-06600	SCHEIBE	2	
14	3HL-F1623-00-11	BEFESTIGUNGSPLATTE 1	1	UR YAMAHA BLACK
15	97001-06012	SCHRAUBE	2	
16	92990-06100	SCHEIBE	2	
17	33G-85132-00	KONSOLE, REFLEKTOR 1	1	
18	90267-40076	BLINDNIET	2	
19	90201-047A2	UNTERLEGSCHIBE	4	
22	3MR-21521-00	KLAPPE, V. KOTFLUGEL	1	
23	3MN-F1685-00-11	KONSOLE, ZULASSUNG	1	
24	3MR-F1624-00	BEFESTIGUNGSPLATTE 2	1	UR YAMAHA BLACK
25	90267-48014	BLINDNIET	6	
26	90201-04325	UNTERLEGSCHIBE	10	



FIG.16 SEITENDECKEL



REF	TEILE.NR	BEZEICHNUNG	STCK	BEMERKUNG
1	3HL-F1711-50	SEITENDECKEL 1 WHITE	1	UR PURPLISH WHITE
	3HL-F1711-10-12	SEITENDECKEL 1 BLACK	1	UR YAMAHA BLACK
	3HL-F1711-60	SEITENDECKEL 1 VIOLET	1	UR DEEP VIOLET
2	43F-21773-00	GUMMITULLE	1	
3	3HL-F1721-50	SEITENDECKEL 2 WHITE	1	UR PURPLISH WHITE
	3HL-F1721-10-12	SEITENDECKEL 2 BLACK	1	UR YAMAHA BLACK
	3HL-F1721-60	SEITENDECKEL 2 VIOLET	1	UR DEEP VIOLET
4	90149-06223	SCHRAUBE	2	
5	90201-062A8	UNTERLEGSCHIBE	2	
6	90480-01401	GUMMITULLE	1	
7	43F-21773-00	GUMMITULLE	2	
8	3HL-F179J-00	AUFKLEBERSTATZ 1	1	UR PURPLISH WHITE
	3HL-F179J-10	AUFKLEBERSTATZ 1	1	UR YAMAHA BLACK
	3HL-F179J-20	AUFKLEBERSTATZ 1	1	UR DEEP VIOLET
9	3HL-F179K-00	AUFKLEBERSTATZ 2	1	UR PURPLISH WHITE
	3HL-F179K-10	AUFKLEBERSTATZ 2	1	UR YAMAHA BLACK
	3HL-F179K-20	AUFKLEBERSTATZ 2	1	UR DEEP VIOLET
10	3HL-F1778-00	POSITIONIERDAMPFER 1	2	
11	3HL-F174T-00	POSITIONIERDAMPFER	1	



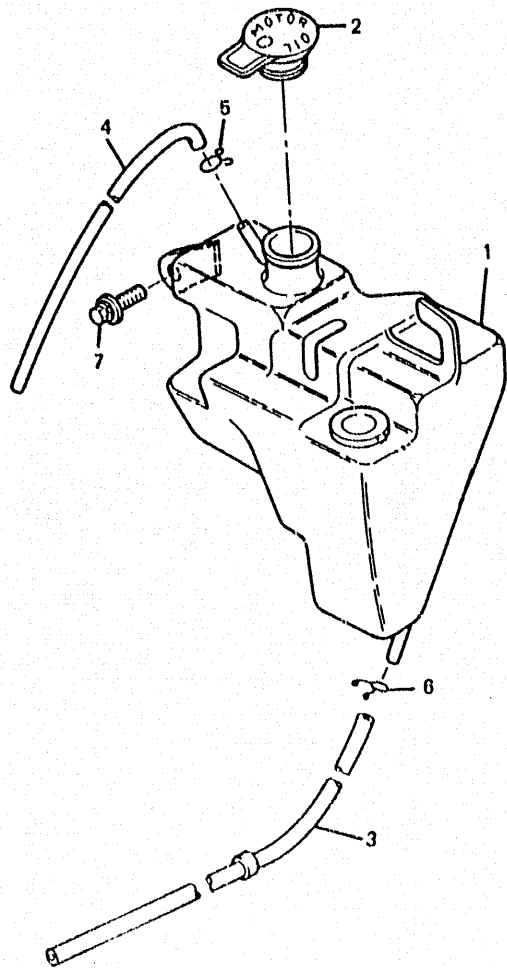
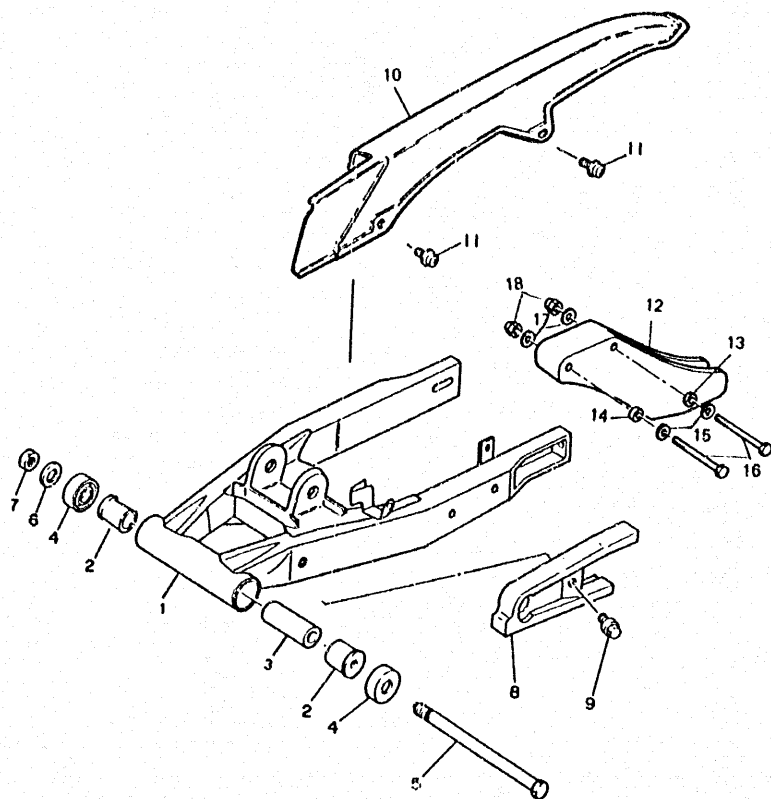


FIG.17 OLTANK

REF	TEILE.NR	BEZEICHNUNG	STCK	BEMERKUNG
1	3HL-F1751-00	OLTANK	1	
2	5T8-F1771-00	GEHAUSE, VERSCHLUSSDECKE	1	
3	90445-09353	SCHLAUCH	1	
4	5T8-F1745-01	ROHR, OLTANKBELUFTUNG	1	
5	90467-08003	KLEMME	1	
6	90467-08003	KLEMME	1	
7	90119-06043	SCHRAUBE, MIT SCHEIBE	1	



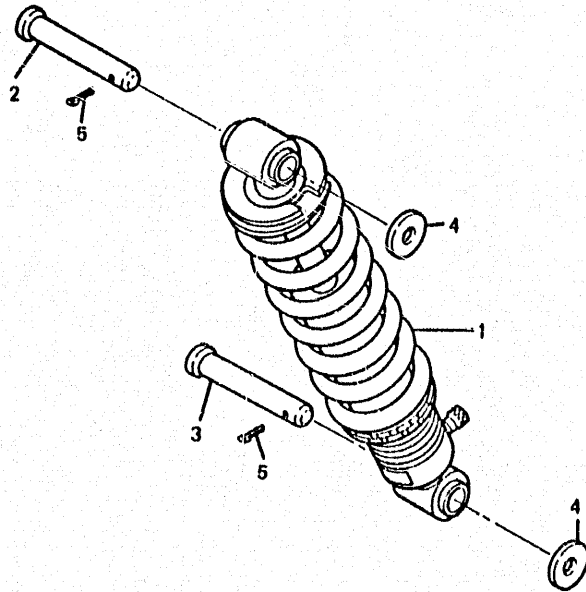
FIG.18 HINTERRADSCHWINGE



REF	TEILE.NR	BEZEICHNUNG	STCK	BEMERKUNG
1	3MP-F2110-01-11	HINTERRADSCHWINGE KOMPL.	1	ORION SILVER
	3MP-F2110-01-12	HINTERRADSCHWINGE KOMPL.	1	NEW PEARL WHITE
2	90386-18099	BUCHSE	2	
3	3HL-F2126-00	DISTANZHULSE	1	
4	401-22128-01	STAUBDECKEL 1	2	
5	5T8-F2141-00	DREHWELLE	1	
6	92990-10600	SCHEIBE	1	
7	95601-10100	STEBOLZEN	1	
8	34X-22151-01	SCHUTZDICHTUNG	1	
9	90159-06059	SCHRAUBE, MIT SCHEIBE	1	
10	3MP-F2311-00	KETTENKASTEN	1	
11	90159-06058	SCHRAUBE, MIT SCHEIBE	2	
12	3HL-F2153-00	FUHRUNG, KETTE	1	
13	3HL-F2243-00	SCHEIBE 1	1	
14	3HL-F2246-00		1	
15	3HL-F2245-00		2	
16	3HL-F2241-00	SCHRAUBE 1	2	
17	3HL-F2244-00	SCHEIBE 2	2	
18	3HL-F2251-00	MUTTER 1	2	



FIG. 19 HINTERRADAUFHANGUNG



REF	TEILE.NR	BEZEICHNUNG	STCK	BEMERKUNG
1	3HL-F2210-00	STOSSDAMPFEREINHEIT, HIN	1	BLACK
2	90240-10072	LASTOEENSTIFT	1	
3	90240-10069	LASTOSENSTIFT	1	
4	92990-10600	SCHEIBE	2	
5	91401-25020	SPLINT	2	



INHALTSVERZEICHNIS

MOTOR

ZYLINDER	B2
KURBELWELLE-KOLBEN	C2
OLPUMPE	D2
EINLASS	E2
VERGASER	F2-G2
AUSLASS	H2
KURBELGEHAUSE	I2
KURBELGEHAUSEDECKEL 1	J2
ANLASSER	K2
KUPPLUNG	L2-B3
GETRIEBE	C3
SCHALTNOCKE-GABEL	D3
SCHALTWELLE-PEDAL	E3

FAHRGESTELL

RAHMEN	F3
KOTFLUGEL	G3
SEITENDECKEL	H3
OLTANK	I3

HINTERRADSCHWINGE	J3
HINTERRADAUFHANGUNG	K3
LENKUNG	L3-B4
VORDERRADGABEL	C4
KRAFTSTOFFTANK	D4-E4
SITZ-TRAGER	F4
VORDERRAD	G4
VORDEBRAOBREMSE	H4
HINTERRAD	I4-J4
LENKER-KABEL	K4
HAUPTBREMSZYLINDER	L4
STANDER-FUSSRASTE	B5
MOTORVERKLEIDUNG 1	C5
LICHTMASCHINE	D5
BLINKLEUCHE	E5
METER	F5
SCHEINWERFER	G5
SCHLUSSLEUCHE	H5
LENKERSCHALTER-HEBEL	I5
ELEKTR-AUSRÜSTUNG	J5-K5

VERZEICHNIS

NUMMERNVERZEICHNIS	L16-M16
--------------------------	---------

INHALTSVERZEICHNIS

MOTOR

ZYLINDER	B2
KURBELWELLE-KOLBEN	C2
OLPUMPE	D2
EINLASS	E2
VERGASER	F2-G2
AUSLASS	H2
KURBELGEHAUSE	I2
KURBELGEHAUSEDECKEL 1	J2
ANLASSER	K2
KUPPLUNG	L2-B3
GETRIEBE	C3
SCHALTNOCKE-GABEL	D3
SCHALTWELLE-PEDAL	E3

FAHRGESTELL

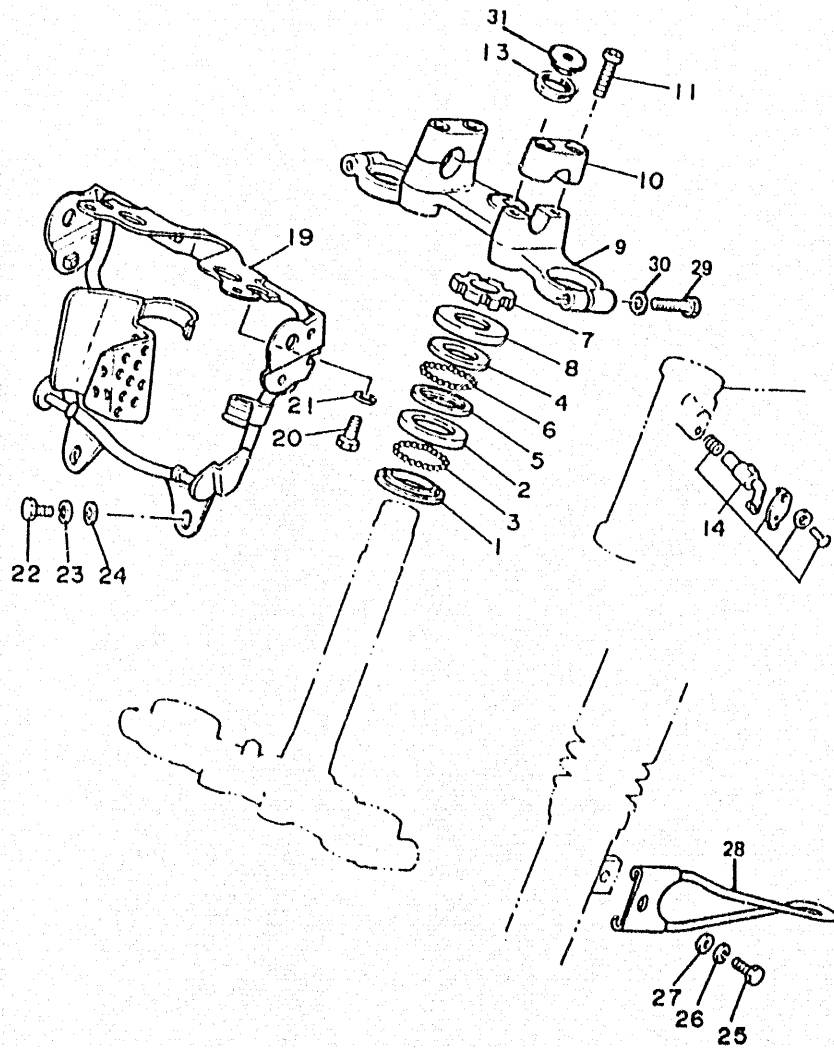
RAHMEN	F3
KOTFLUGEL	G3
SEITENDECKEL	H3
OLTANK	I3

HINTERRADSCHWINGE	J3
HINTERRADAUFHANGUNG	K3
LENKUNG	L3-B4
VORDERRADGABEL	C4
KRAFTSTOFFTANK	D4-E4
SITZ-TRAGER	F4
VORDERRAD	G4
VORDEBRAOBREMSE	H4
HINTERRAD	I4-J4
LENKER-KABEL	K4
HAUPTBREMSZYLINDER	L4
STANDER-FUSSRASTE	B5
MOTORVERKLEIDUNG 1	C5
LICHTMASCHINE	D5
BLINKLEUCHE	E5
METER	F5
SCHEINWERFER	G5
SCHLUSSLEUCHE	H5
LENKERSCHALTER-HEBEL	I5
ELEKTR-AUSRÜSTUNG	J5-K5

VERZEICHNIS

NUMMERNVERZEICHNIS	L16-M16
--------------------------	---------

FIG. 20 LENKUNG



REF	TEILE.NR	BEZEICHNUNG	STCK	BEMERKUNG
29	3HL-F3452-10	BEFESTIGUNGSSCHRAUBE 2	2	
30	3HL-F3457-10	SCHEIBE	1	
31	3HL-F3469-00	KLEMME, SCHRAUBE	1	



3MRI321-9200

B4

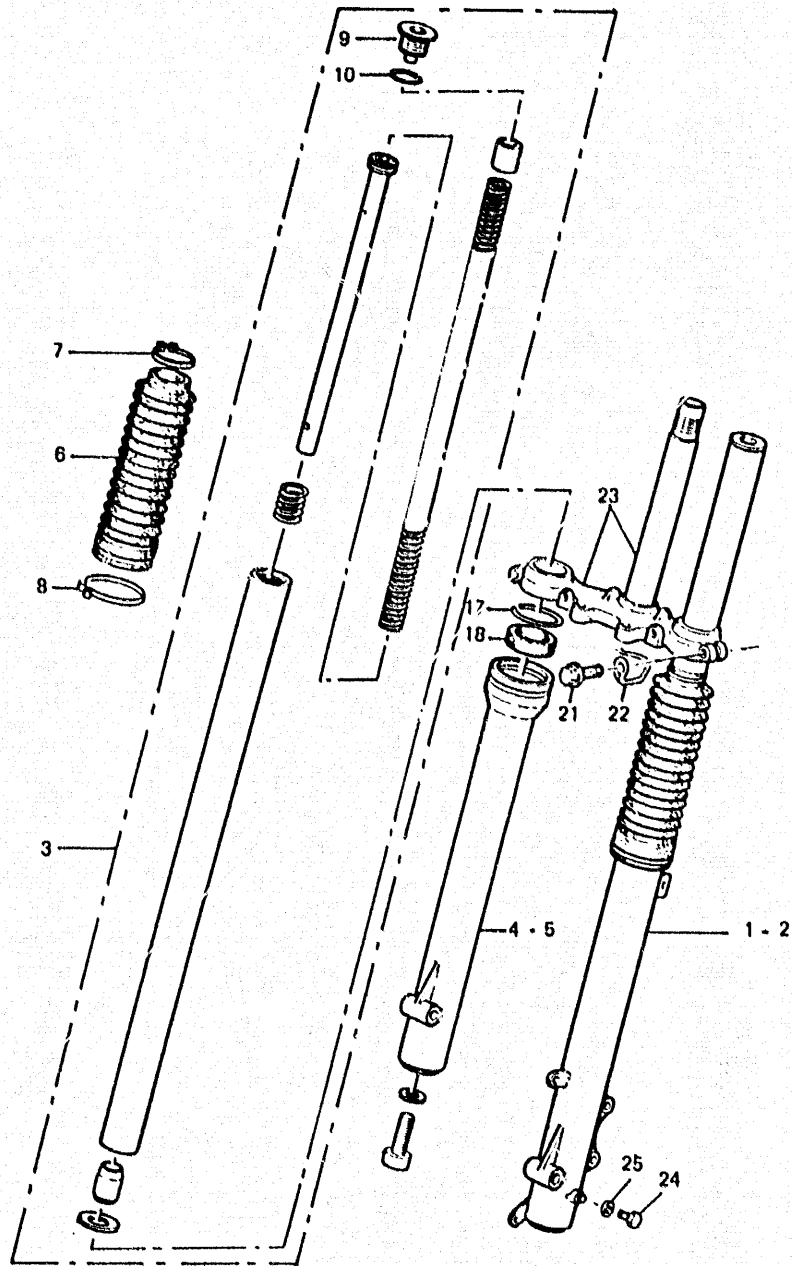
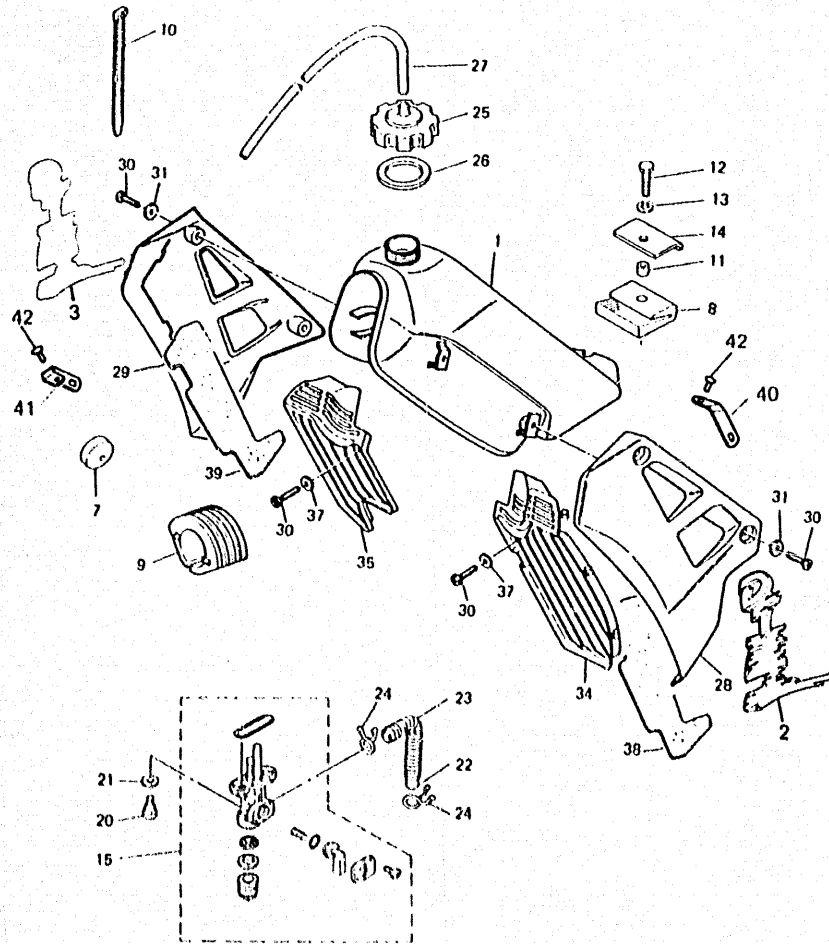


FIG. 21 VORDEKFRADGABEL

REF	TEILE.NR	BEZEICHNUNG	STCK	BEMERKUNG
1	3HL-F3102-20	GABELBEIN (LINKS)	1	
2	3HL-F3103-00	GABELBEIN (RECHTS)	1	
3	3HL-F3110-00	INNERES GABELBEINROHR 1	2	
4	3HL-F3126-10	AUSSERES ROHR 1	1	SILVER
5	3HL-F3136-00	AUSSERES ROHR 2	1	SILVER
6	3HL-F3191-40	MANSCHETTE	2	UR PW, YB.
	3HL-F3191-30	MANSCHETTE	2	UR DP
7	3HL-F3192-00	BAND	2	
8	3HL-F3192-10	BAND	2	
9	3HL-F3111-00	SCHRAUBE, VERSCHLUSSKAPP	1	
10	3HL-F3114-00	DICHTUNG	2	
17	3HL-F3156-00	KLEMME, WELLENDICHTRING	2	
18	3HL-F3145-00	WELLENDICHTRING	2	
21	3HL-F3451-10	BEFESTIGUNGSSCHRAUBE 1	1	
22	5JO-23317-00	KABELHALTER	1	
23	3HL-F3340-10	UNTERE KONSOLE KOMPL.	1	ORION SILVER
24	3HL-F3119-00	ABLASSSCHRAUBE	2	
25	3HL-F3129-00	DICHTUNG, ABLASSSCHRAUBE	2	



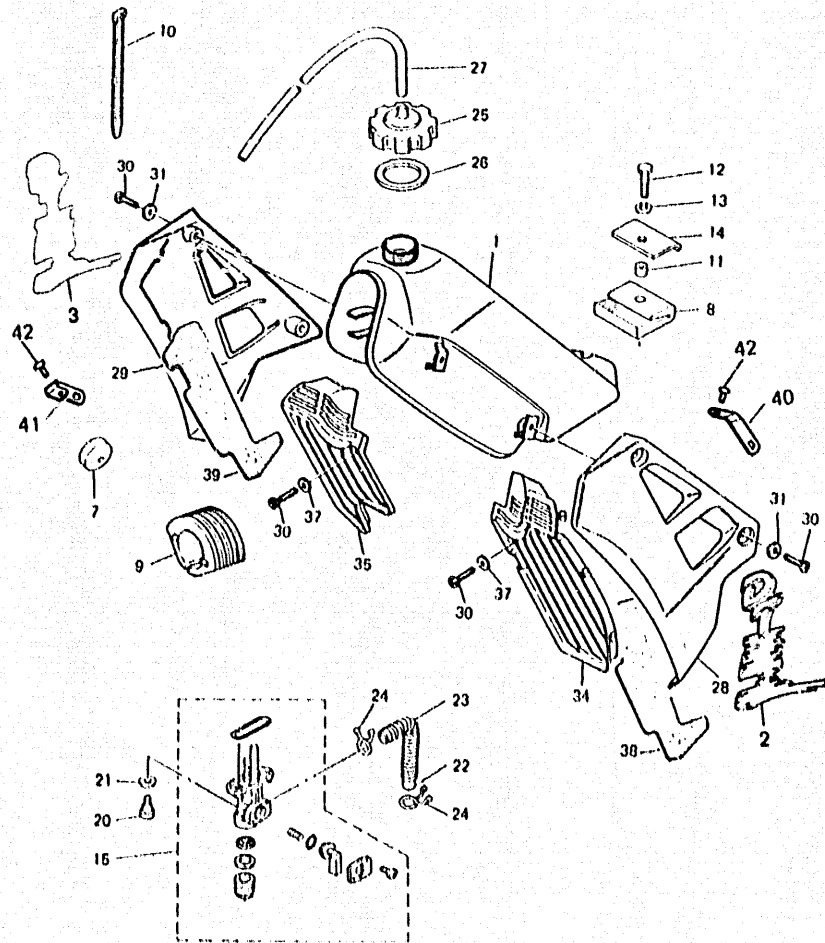
FIG. 22 KRAFTSTOFFTANK



REF	TEILE.NR	BEZEICHNUNG	STCK	BEMERKUNG
1	3MN-F4110-00-15	KRAFTSTOFFTANK KOMPL.	1	UR DEEP VIOLET
	3MN-F4110-00-11	KRAFTSTOFFTANK KOMPL.	1	UR YAMAHA BLACK
	3MN-F4110-00-14	KRAFTSTOFFTANK KOMPL.	1	UR PURPLISH WHITE
2	3HL-F179L-00	AUFKLEBER, KRAFTSTOFFTAN1	1	UR PURPLISH WHITE
	3HL-F179L-10	AUFKLEBER, KRAFTSTOFFTAN1	1	UR YAMAHA BLACK
	3HL-F179L-20	AUFKLEBER, KRAFTSTOFFTAN1	1	UR DEEP VIOLET
3	3HL-F179M-00	AUFKLEBER, KRAFTSTOFFTAN2	1	UR PURPLISH WHITE
	3HL-F179M-10	AUFKLEBER, KRAFTSTOFFTAN2	1	UR YAMAHA BLACK
	3HL-F179M-20	AUFKLEBER, KRAFTSTOFFTAN2	1	UR DEEP VIOLET
7	26H-F4181-00	DAMPFUNGLAGER 1	2	
8	5T8-F4182-01	DAMPFUNGLAGER 2	1	
9	34L-24184-00	DAMPFUNGLAGER 4	1	
10	90465-13154	SCHELLE	1	
11	90387-06825	HULSE	1	
12	97001-06030	SCHRAUBE	1	
13	92990-06100	SCHEIBE	1	
14	5T8-F4186-00	SPEZIALSCHEIBE	1	
15	5T8-F4500-01	KRAFTSTOFFHAHN 1	1	
20	90149-06011	SCHRAUBE	2	
21	90202-06010	UNTERLEGSCHEIBE	2	
22	3HL-24311-00	KRAFTSTOFFROHR 1	1	
23	90501-08410	DRUCKFEDER	1	
24	90467-08003	KLEMME	2	
25	5T8-F4611-00	GEHAUSE, VERSCHLUSSKAPPE	1	
26	5T8-F4612-00	DICHTUNG, VERSCHLUSSKAPP	1	
27	90445-09100	SCHLAUCH	1	



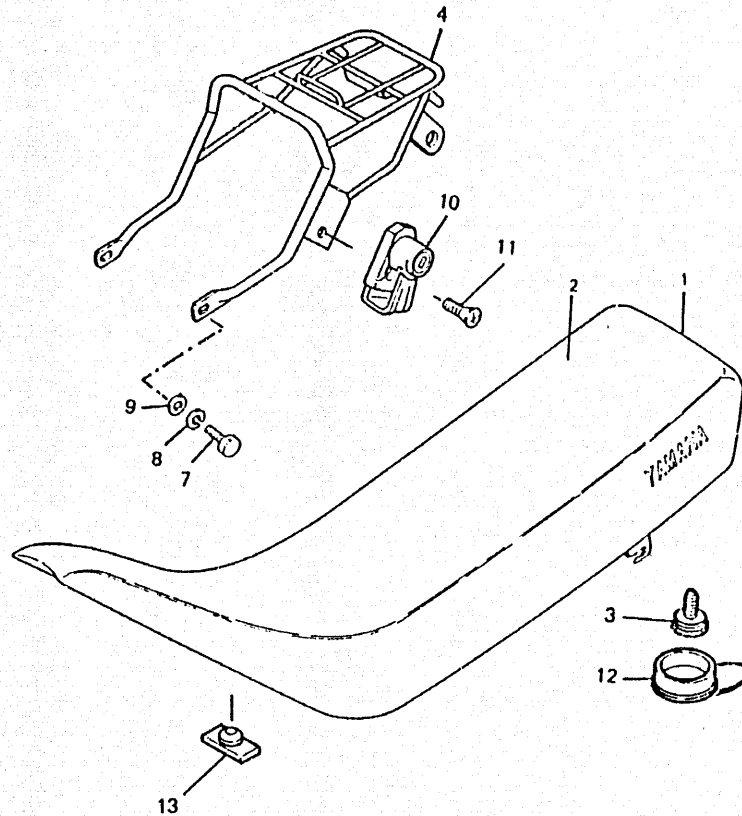
FIG.22 KRAFTSTOFFTANK



REF	TEILE.NR	BEZEICHNUNG	STCK	BEMERKUNG
28	3MN-F172A-30	TAFEL 1	1	UR PURPLISH WHITE
	3MN-F172A-10	TAFEL 1	1	UR YAMAHA BLACK
	3MN-F172A-40	TAFEL 1	1	UR DEEP VIOLET
29	3MN-F172G-30	TAFEL 2	1	UR PURPLISH WHITE
	3MN-F172G-10	TAFEL 2	1	UR YAMAHA BLACK
	3MN-F172G-40	TAFEL 2	1	UR DEEP VIOLET
30	92506-06012	ZYLINDERKOPFSCHRAUBE	8	
31	90201-06059	UNTERLEGSCHIBE	8	
34	3HL-F172F-00	TAFEL 2	1	UR BLACK
35	3HL-F172H-00	TAFEL 1	1	UR BLACK
36	3HL-F4164-00	EMBLEM 4	1	
37	90201-062A8	UNTERLEGSCHIBE	4	
38	3HL-F414H-00	ZIERVERKLEIDUNG, ABDECKU	1	
39	3HL-F414J-00	ZIERVERKLEIDUNG, ABDECKU	1	
40	3HL-F172K-00	KONSOLE 1	1	
41	3HL-F172L-00	KONSOLE 2	1	
42	3HL-F1728-00	NIET	2	
	3MN-F171L-00	POSITIONIERDAMPER	1	
	3MN-F171M-00	POSITIONIERDAMPER	1	



FIG.23 SITZ TRAGER



REF	TEILE.NR	BEZEICHNUNG	STCK	BEMERKUNG
1	3HL-F4730-70	SITZBANK VIVID MAGENTA	1	UR PURPLISH WHITE
	3HL-F4730-80	SITZBANK FARAWAY BLUE	1	UR YAMAHA BLACK
	3HL-F4730-90	SITZBANK SOLID FINE SILV	1	UR DEEP VIOLET
2	3HL-F4731-70	DECKEL, DOPPELSITZ VM.	1	UR FURPLISH WHITE
	3HL-F4731-80	DECKEL, DOPPELSITZ FB.	1	UR YAMAHA BLACK
	3HL-F4731-90	DECKEL, DOPPELSITZ SFS.	1	UR DEEP VIOLET
3	3HL-F4739-00	BEFESTIGUNGSSCHRAUBE, SI	1	
4	3MP-F4830-00-11	ZWISCHENTRAGER KOMPL.	1	LOW GLOSS BLACK
7	97016-06C20	SCHRAUBE	2	
8	92906-08100	SCHEIBE	2	
9	92906-08600	SCHEIBE	2	
10	5T8-F1398-00	HALTER, STURZHELM	1	
11	92701-06018	SENKSCHEIBE	1	
12	3HL-F4742-10	GUMMITULLE	1	
13	509-24724-00	DAMPFER, SITZ	2	



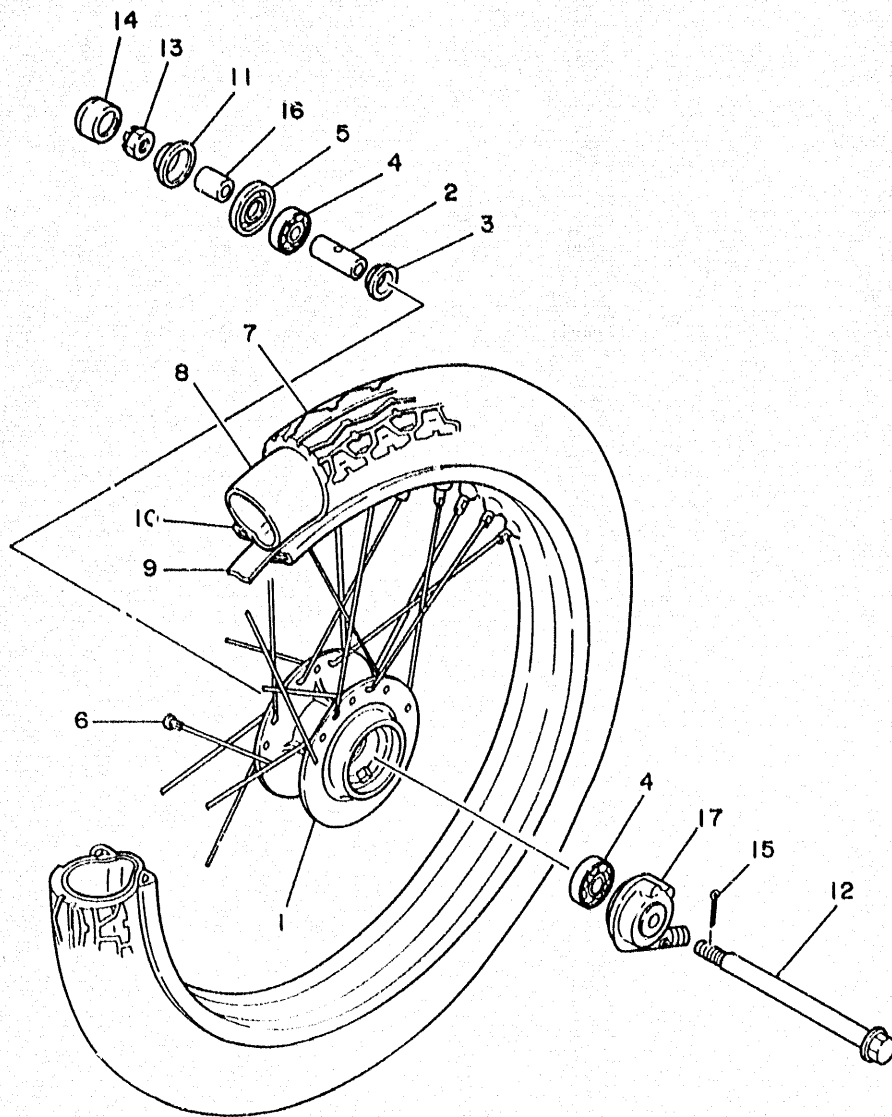


FIG. 24 VORDERRAD

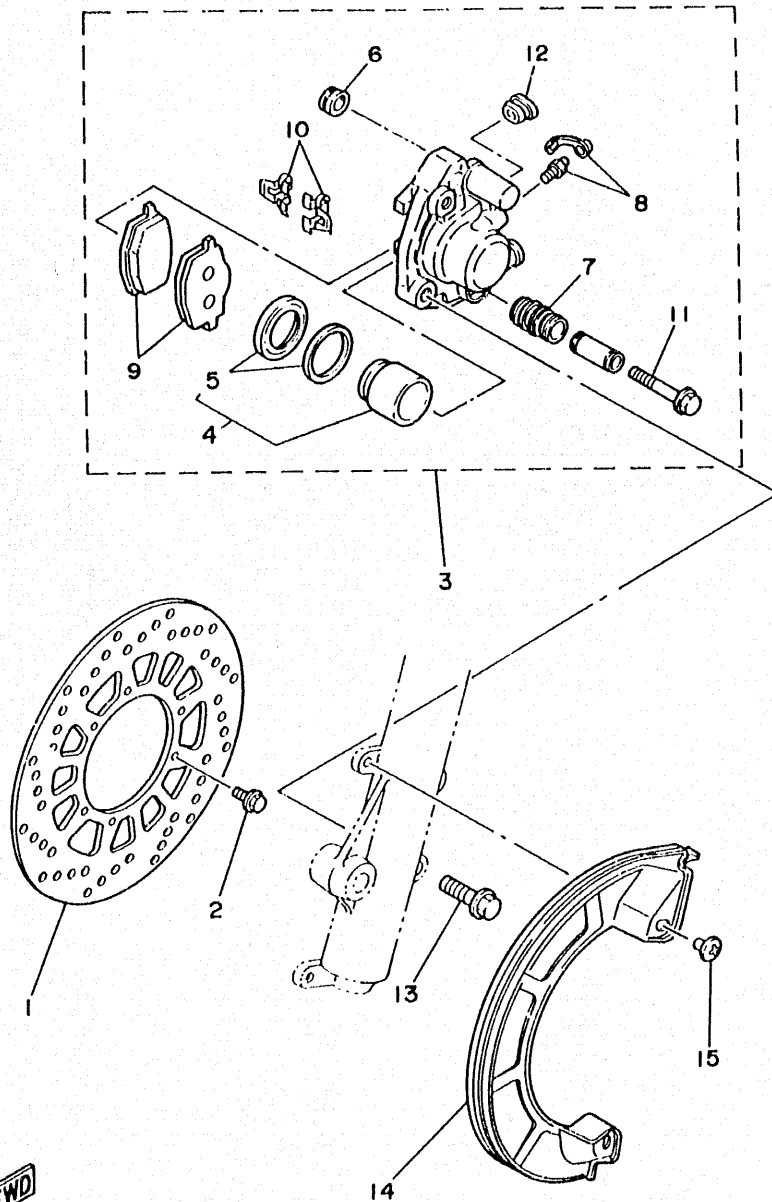
REF	TEILE.NR	BEBEICHNUNG	STCK	BEMERKUNG
1	3HL-F5111-00-12	RADNABE, VORNE	1	ORION SILVER
2	90560-12208	ABSTANDHALTER	1	
3	5T8-F5315-00	FLANSCH, ABSTANDHALTER	1	
4	93306-301Y2	LAGER	2	
5	93102-18008	WELLENDICHTRING	1	
6	3HL-25104-10	SPEICHENSATZ, VORNE	1	
7	94170-218A1	REIFEN	1	
8	94225-21812	SCHLAUCH	1	
9	94330-21814	FELGENBAND	1	
10	94416-21471	FELGE	1	
11	5T8-F5118-00	STAUBDECKEL, RADNABE	1	
12	5T8-F5181-00	STOSSFANGER, HINTEN (L)	1	
13	90171-12015	KRONENMUTTER	1	
14	5T8-F5188-00	KAPPE	1	
15	91401-30025	SPLINT	1	
16	90387-12283	HULSE	1	
17	3HL-25190-10	GETRIEBEEINHEIT	1	



3MNI332-9240

G4

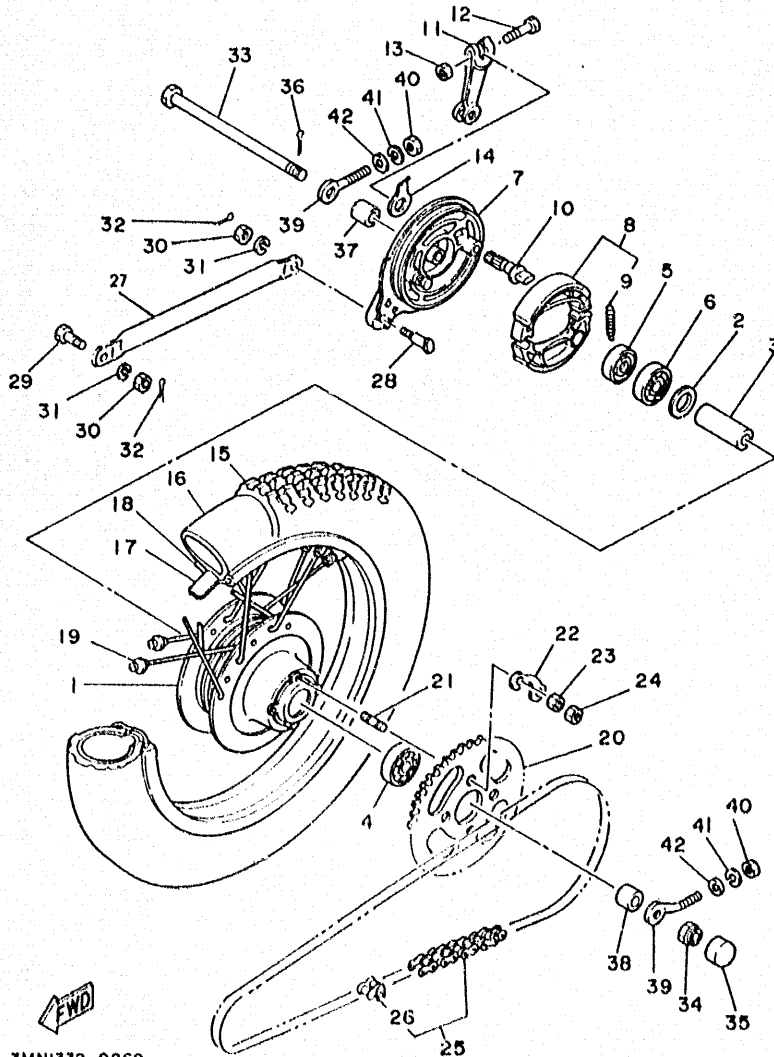
FIG.25 VORDERRADBREMSE



REF	TEILE.NR	BEZEICHNUNG	STCK	BEMERKUNG
1	34X-25831-00	BREMSSCHEIBE	1	
2	90109-06757	SCHRAUBE	6	
3	34X-2580T-00	BREMSSATTEL KOMPL. (L)	1	
4	34X-W0057-00	KOLBEN, BREMSSATTEL	1	
5	34X-W0047-00	BREMSSATTEL-DICHTUNGSSATZ	1	
6	5R2-25917-00	MANSCHETTE, BREMSSATTEL	1	
7	34X-25937-00	MANSCHETTE 2	1	
8	51L-W0048-00	ENTLUFTUNGSSCHRAUBENSATZ	1	
9	34X-W0046-01	BREMSBELAGSATZ, HINTEN	1	
10	34X-25919-00	STUTZE, BREMSBELAGPLATTE	2	
11	34X-25926-00	SCHRAUBE	1	
12	34X-25845-00	KAPPE, ANZEIGER	1	
13	90105-10308	SCHRAUBE, MIT SCHEIBE	2	
14	3HL-25715-40	DECKEL 1 WHITE	1	UR PURPLISH WHITE
	3HL-25715-50	DECKEL 1 BLACK	1	UR YAMAHA BLACK
	3HL-25715-60	DECKEL 1 VIOLET	1	UR DEEP VIOLET
15	90149-06194	SCHRAUBE	2	

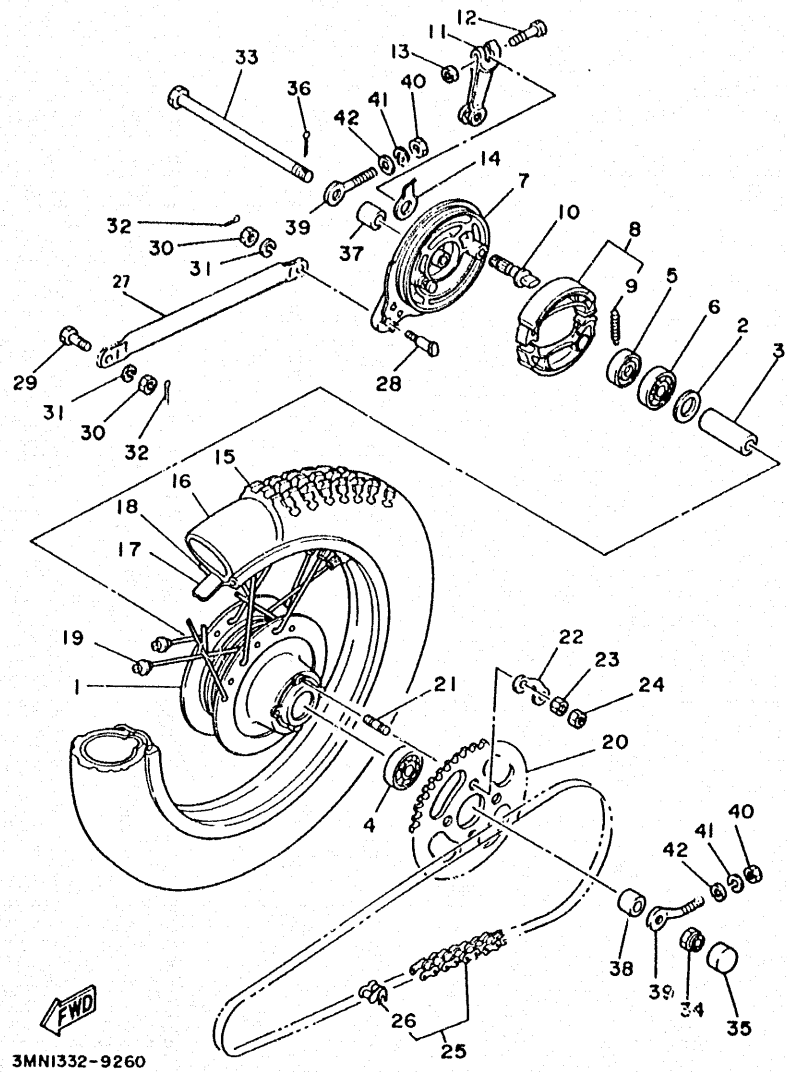


FIG. 26 HINTERRAD



3MNI332-9260

REF	TEILE.NR	BEZEICHNUNG	STCK	BEMERKUNG
1	5T8-F5311-10-12	RADNABE, HINTEN	1	ORION SILVER
2	5T8-F5315-00	FLANSCH, ABSTANDHALTER	1	
3	90560-12207	ABSTANDHALTER	1	
4	93306-301Y1	LAGER	1	
5	93106-20002	WELLENDICHTRING	1	
6	93306-301Y0	LAGER	1	
7	5T8-F5321-03	PLATTE, BREMSANKER	1	
8	18A-W2534-00	BREMSSCHUHSATZ 2	1	
9	90506-18288	ZUGFEDER	2	
10	3Y6-25351-00	NOCKENWELLE	1	
11	5R0-25355-00	HEBEL, NOCKENWELLE	1	
12	90101-06278	SCHRAUBE	1	
13	95601-06100	STEBOLZEN	1	
14	5T8-F533A-00	PLATTE, ANZEIGER	1	
15	94190-188A2	REIFEN	1	
16	94232-18838	SCHLAUCH	1	
17	94332-18833	FELGENBAND	1	
18	94418-18171	FELGE	1	
19	5J0-25304-00	SPEICHENSATZ, HINTEN	1	
20	17W-25448-10	ABTRIEBSKETTENRAD	1	YAMAHA BLACK
21	90116-08804	STEBOLZEN	4	
22	5T8-F5412-01	SCHEIBE	2	
23	90170-08258	MUTTER	3	
24	90179-08842	MUTTER	1	
25	94580-52122	KETTE	1	
26	94680-52001	KETTENSCHLOSS	1	
27	3HL-F5371-00-11	ZUGSTANGE	1	
28	90109-08183	SCHRAUBE	1	

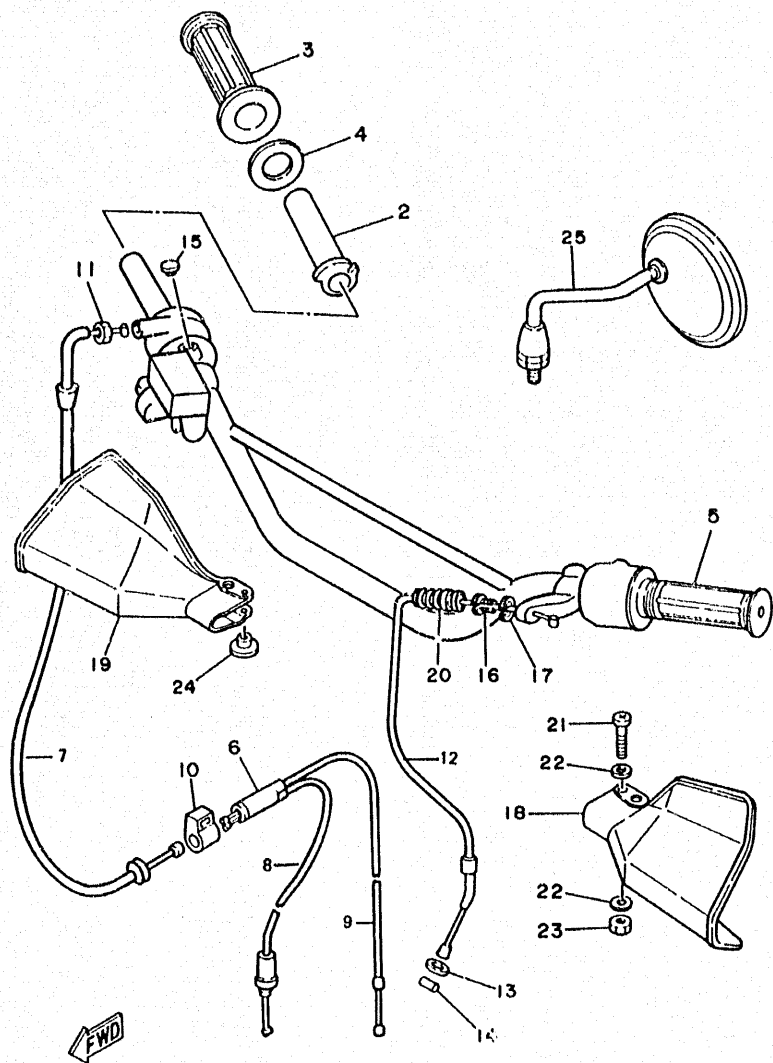


3MNI332-9260

FIG.26 HINTERRAD

REF	TEILE.NR	BEZEICHNUNG	STCK	BEMERKUNG
29	90109-08368	SCHRAUBE	1	
30	95303-08700	MUTTER	2	
31	92990-08100	SCHEIBE	2	
32	91401-20015	SPLINT	2	
33	5T8-F5381-00	RADACHSE	1	
34	90171-12015	KRONENMUTTER	1	
35	5T8-F5188-00	KAPPE	1	
36	91401-30025	SPLINT	1	
37	90387-12819	HULSE	1	
38	90387-12820	HULSE	1	
39	1MK-F5389-00	KETTENSANNER 2	2	
40	95303-06600	MUTTER	2	
41	92990-06100	SCHEIBE	2	
42	92901-06600	SCHEIBE	2	

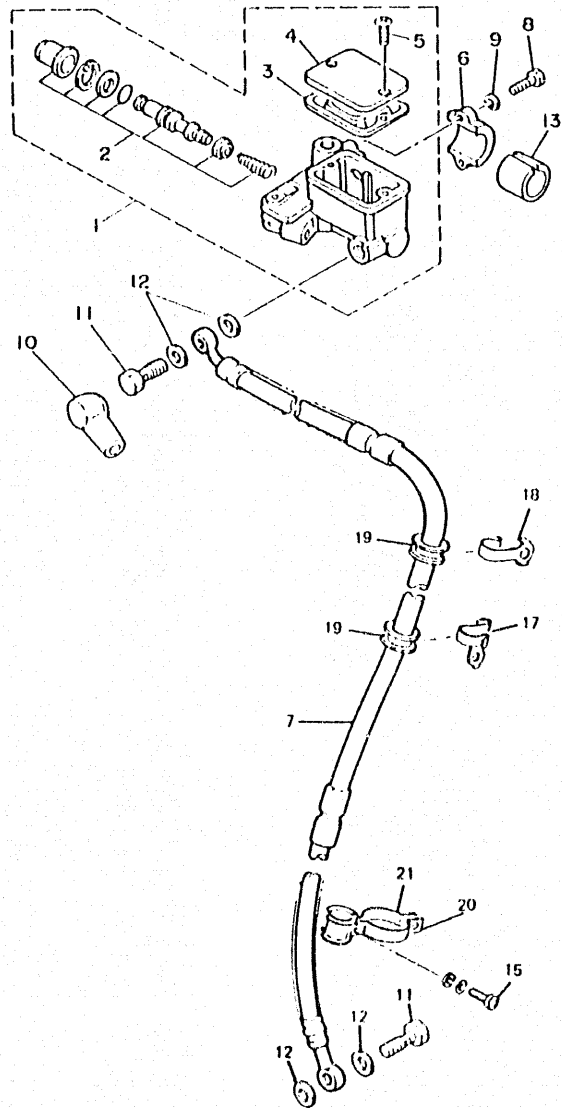
FIG.27 LENKER KABEL



3MR1321-9270

REF	TEILE.NR	BEZEICHNUNG	STCK	BEMERKUNG
1	3HL-F6111-00-13	LENKER	1	ORION SILVER
2	434-26243-00	FUHRUNGSRÖHR, GASSEIL	1	
3	5T8-F6242-00	GRIFF (R)	1	
4	1M1-26249-01	BLATTRING	1	
5	5T8-F6241-00	GRIFF (L)	1	
6	5T8-F6261-00	SEILZUGVERBINDUNG	1	
7	3HL-F6311-10	GASSEIL 1	1	
8	3HL-F6312-00	GASSEIL 2	1	
9	3MP-F6321-00	PUMPENSEIL	1	
10	5T8-F6393-01	HALTER	1	
11	90170-10038	MUTTER	1	
12	3MR-F6335-00	KUPPLUNGSSEIL	1	
13	92901-06600	SCHEIBE	1	
14	5T8-F6363-00	SEILZUGENDE	1	
15	90338-09012	VERSCHLÜSS	1	
16	90123-08046	SCHRAUBE	1	
17	90179-08148	MUTTER	1	
18	3BN-26141-20	BURSTENSCHUTZ 1 WHITE	1	UR PURPLISH WHITE
	2KF-26141-00	BURSTENSCHUTZ 1 BLACK	1	UR YAMAHA BLACK
	3TB-26141-50	BURSTENSCHUTZ 1 VIOLET	1	UR DEEP VIOLET
19	3BN-26142-20	BURSTENSCHUTZ 2 WHITE	1	UR PURPLISH WHITE
	2KF-26142-00	BURSTENSCHUTZ 2 BLACK	1	UR YAMAHA BLACK
	3BN-26142-30	BURSTENSCHUTZ 2 VIOLET	1	UR DEEP VIOLET
20	1E6-26342-00	MANSCHETTE, SEILZUG	1	
21	92501-06035	ZYLINDERKOPFSCHRAUBE	1	
22	92901-06600	SCHEIBE	2	
23	95303-06700	MUTTER	1	
24	90387-06500	HULSE	1	
25	55V-26280-00	RUCKBLICKSPIEGEL KOMPL	1	

FIG. 28 HAUPTBREMSZYLINDER



REF	TEILE.NR	BEZEICHNUNG	STCK	BEMERKUNG
1	2KF-25850-00	HAUPTBREMSZYLINDER KOMPL	1	
2	59X-W0041-00	HAUPTBREMSZYLINDERSATZ	1	
3	55U-25854-00	MEMBRAN	1	
4	2KF-25852-01	KAPPE, BEHALTER	1	
5	98506-04012	ZYLINDERKOPFSCHRAUBE	2	
6	56A-25867-00	KONSOLE, HAUPTBREMSZYL.	1	
7	3HL-25872-12	BREMSSCHLAUCH 1	1	
8	97016-06025	SCHRAUBE	2	
9	92906-06100	SCHEIBE	2	
10	4L0-25862-00	MANSCHETTE, HAUPTBREMSZY	1	
11	90401-10034	HOHLSCHRAUBE	2	
12	90201-10118	UNTERLEGSCHIBE	4	
13	90387-225N2	HULSE	1	
15	97506-06618	SCHRAUBE, MIT SCHEIBE	2	
17	3HL-F3319-30	KABELHALTER 2	1	
18	3HL-F3319-20	KABELHALTER 2	2	
19	3HL-F3389-00	KABELFUHRUNG	2	
20	3HL-F3318-20	KABELHALTER 1	1	
21	3HL-F3318-10	KABELHALTER 1	1	



INHALTSVERZEICHNIS

MOTOR

ZYLINDER	B2
KURBELWELLE-KOLBEN	C2
OLPUMPE	D2
EINLASS	E2
VERGASER	F2-G2
AUSLASS	H2
KURBELGEHAUSE	I2
KURBELGEHAUSEDECKEL 1	J2
ANLASSER	K2
KUPPLUNG	L2-B3
GETRIEBE	C3
SCHALTNOCKE-GABEL	D3
SCHALTWELLE-PEDAL	E3

FAHRGESTELL

RAHMEN	F3
KOTFLUGEL	G3
SEITENDECKEL	H3
OLTANK	I3

HINTERRADSCHWINGE	J3
HINTERRADAUFHANGUNG	K3
LENKUNG	L3-B4
VORDERRADGABEL	C4
KRÄFSTOFFTANK	D4-E4
SITZ-TRAGER	F4
VORDERRAD	G4
VORDEBRAOBREMSE	H4
HINTERRAD	I4-J4
LENKER-KABEL	K4
HAUPTBREMSZYLINDER	L4
STANDER-FUSSRASTE	B5
MOTORVERKLEIDUNG 1	C5
LICHTMASCHINE	D5
BLINKLEUCHE	E5
METER	F5
SCHEINWERFER	G5
SCHLUSSLEUCHE	H5
LENKERSCHALTER-HEBEL	I5
ELEKTR-AUSRÜSTUNG	J5-K5

VERZEICHNIS

NUMMERNVERZEICHNIS	L16-M16
--------------------------	---------

INHALTSVERZEICHNIS

MOTOR

ZYLINDER	B2
KURBELWELLE-KOLBEN	C2
OLPUMPE	D2
EINLASS	E2
VERGASER	F2-G2
AUSLASS	H2
KURBELGEHAUSE	I2
KURBELGEHAUSEDECKEL 1	J2
ANLASSER	K2
KUPPLUNG	L2-B3
GETRIEBE	C3
SCHALTNOCKE-GABEL	D3
SCHALTWELLE-PEDAL	E3

FAHRGESTELL

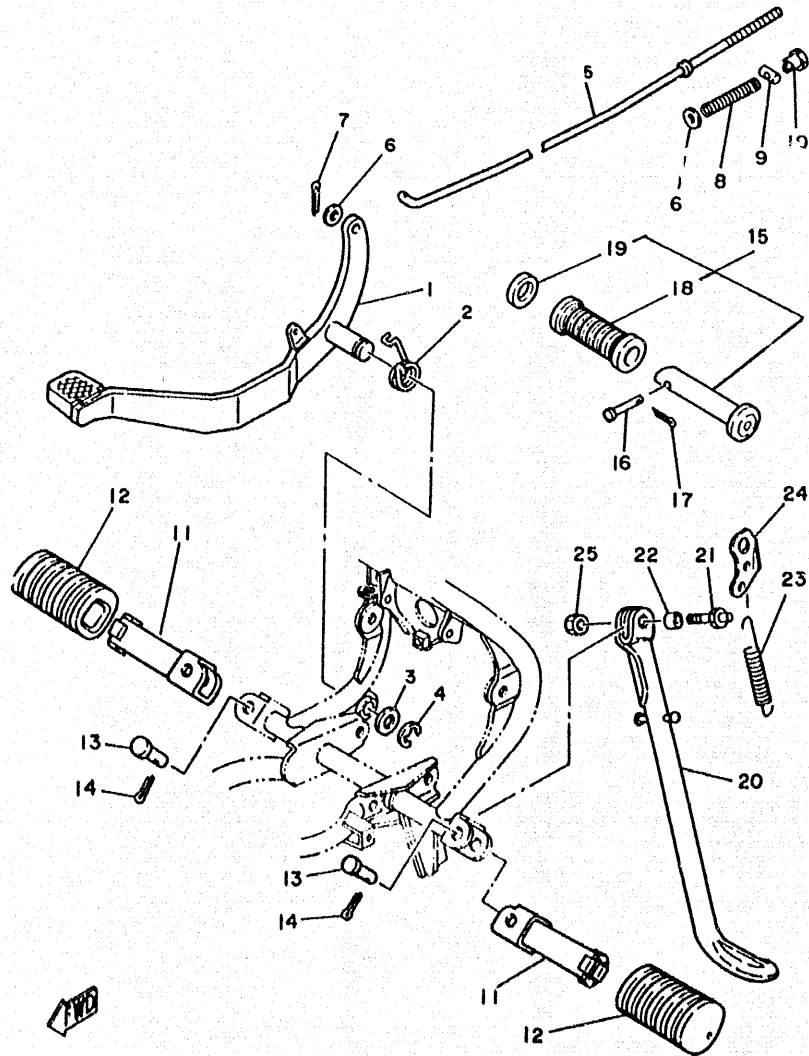
RAHMEN	F3
KOTFLUGEL	G3
SEITENDECKEL	H3
OLTANK	I3

HINTERRADSCHWINGE	J3
HINTERRADAUFHANGUNG	K3
LENKUNG	L3-B4
VORDERRADGABEL	C4
KRAFTSTOFFTANK	D4-E4
SITZ-TRAGER	F4
VORDERRAD	G4
VORDEBRAOBREMSE	H4
HINTERRAD	I4-J4
LENKER-KABEL	K4
HAUPTBREMSZYLINDER	L4
STANDER-FUSSRASTE	B5
MOTORVERKLEIDUNG 1	C5
LICHTMASCHINE	D5
BLINKLEUCHE	E5
METER	F5
SCHEINWERFER	G5
SCHLUSSLEUCHE	H5
LENKERSCHALTER-HEBEL	I5
ELEKTR-AUSRÜSTUNG	J5-K5

VERZEICHNIS

NUMMERNVERZEICHNIS	L16-M16
--------------------------	---------

FIG. 29 STANDER FUSSRASTE



REF	TEILE.NR	BEZEICHNUNG	STCK	BEMERKUNG
1	5T8-F7211-00	BREMSPEDAL	1	
2	90508-32354	ZUGFEDER	1	
3	90201-14813	UNTERLEGSCHIBE	1	
4	93430-10803	SPRENGRING	1	
5	3MP-F7231-00	BREMSSTANGE	1	
6	92901-06600	SCHEIBE	2	
7	91401-20015	SPLINT	1	
8	90501-10245	DRUCKFEDER	1	
9	90249-12008	STIFT	1	
10	90179-06176	MUTTER	1	
11	5T8-F7421-00	FUSSRASTE 2	2	
12	5T8-F7413-00	DECKEL, FUSSRASTE	2	
13	91701-08038	LASTOSENSTIFT	2	
14	91401-20015	SPLINT	2	
15	5T8-F7431-00	FUSSRASTE 1, HINTEN	2	
16	91701-06032	LASTOSENSTIFT	2	
17	91401-16012	SPLINT	2	
18	5T8-F7433-00	DECKEL, HINTERE FUSSRASTE	2	
19	90201-20279	UNTERLEGSCHIBE	2	
20	1NN-F7311-00-11	SEITENSTANDER	1	
21	90109-08829	SCHRAUBE	1	
22	90387-08884	HULSE	1	
23	90506-20041	ZUGFEDER	2	
24	5T8-F7315-00	GESTANGE, SEITENSTANDER	2	
25	95303-08700	MUTTER	1	

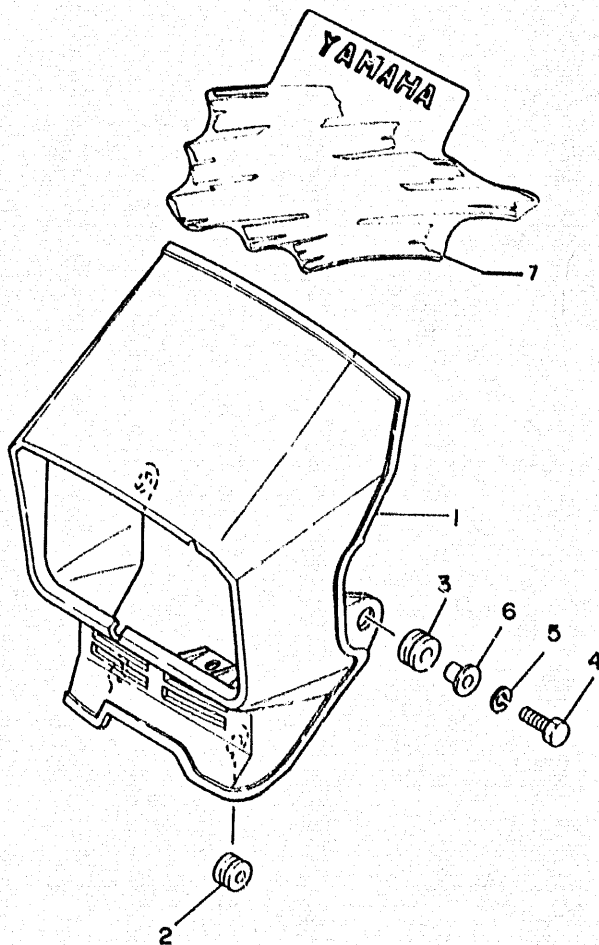
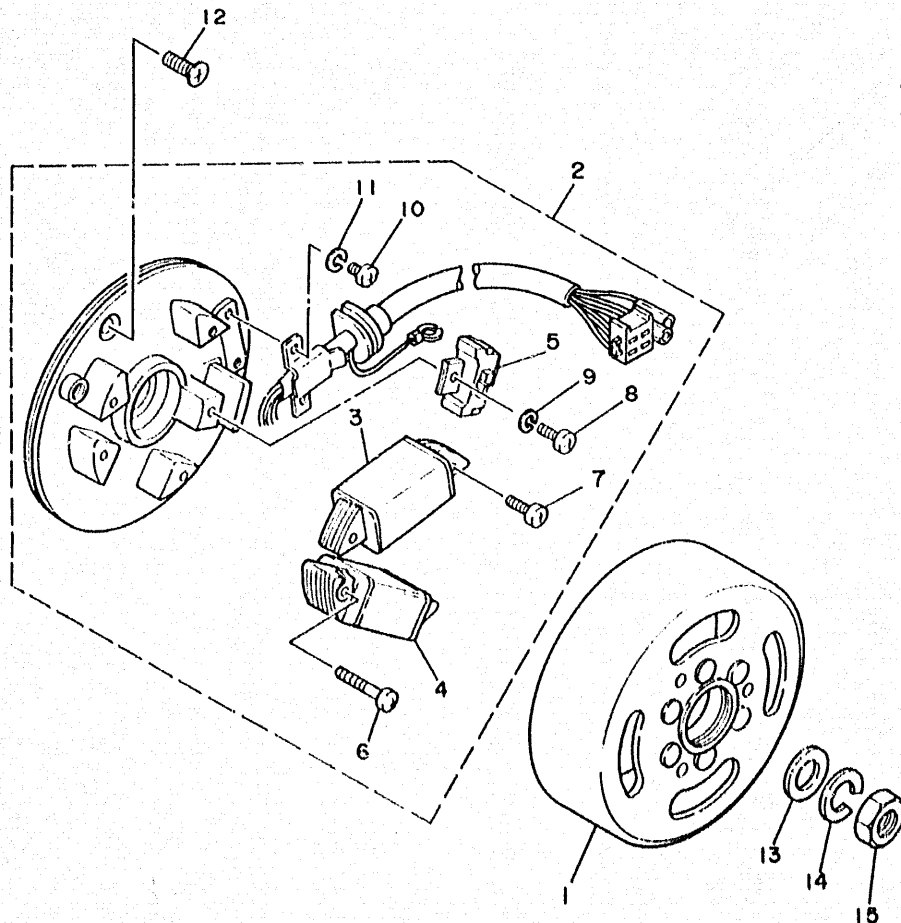


FIG. 30 MOTORVERKLEIDUNG

REF	TEILE.NR	BEZEICHNUNG	STCK	BEMERKUNG
1	1NN-F8351-00-16	KAROSSERIE, VERKLEIDUNG	1	UR DEEP VIOLET
	1NN-F8351-00-12	KAROSSERIE, VERKLEIDUNG	1	UR YAMAHA BLACK
	1NN-F8351-00-15	KAROSSERIE, VERKLEIDUNG	1	UR PURPLISH WHITE
2	90480-12053	GUMMITULLE	2	
3	90480-14023	GUMMITULLE	2	
4	97001-06025	SCHRAUBE	2	
5	92906-06100	SCHEIBE	2	
6	90387-07391	HULSE	2	
7	3HL-F8368-A0	EMBLEM	1	UR DEEP VIOLET
	3HL-F8368-80	EMBLEM	1	UR PURPLISH WHITE
	3HL-F8368-90	EMBLEM	1	UR YAMAHA BLACK



FIG. 31 LICHTMASCHINE



REF	TEILE.NR	BEZEICHNUNG	STCK	BEMERKUNG
1	3MR-85550-00	ROTOR KOMPL.	1	
2	3MP-85560-00	GRUNDPLATTE KOMPL.	1	
3	5G3-85520-M1	LADESPULE	1	
4	2AL-81313-M0	LICHTSPULE 1	1	
5	3HL-85580-00	IMPULSSPULE	1	
6	98511-04025	ZYLINDERKOPFSCHRAUBE	2	
7	98511-04012	ZYLINDERKOPFSCHRAUBE	2	
8	98580-04010	ZYLINDERKOPFSCHRAUBE	1	
9	92901-04100	SCHEIBE	1	
10	98501-04006	ZYLINDERKOPFSCHRAUBE	2	
11	92901-04100	SCHEIBE	2	
12	98701-05016	SENKSCHAUBE	2	
13	90201-12535	UNTERLEGSCHIBE	1	
14	92901-12100	SCHEIBE	1	
15	90170-12175	MUTTER	1	



3MR1321-9310

D5

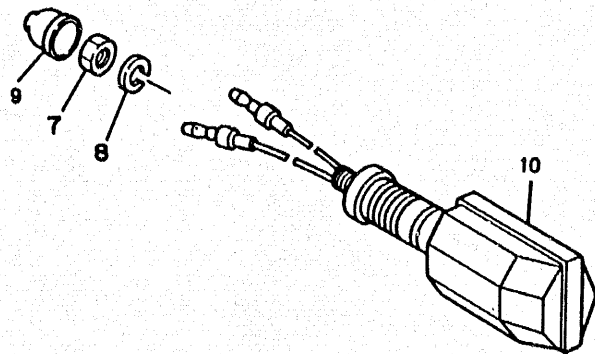
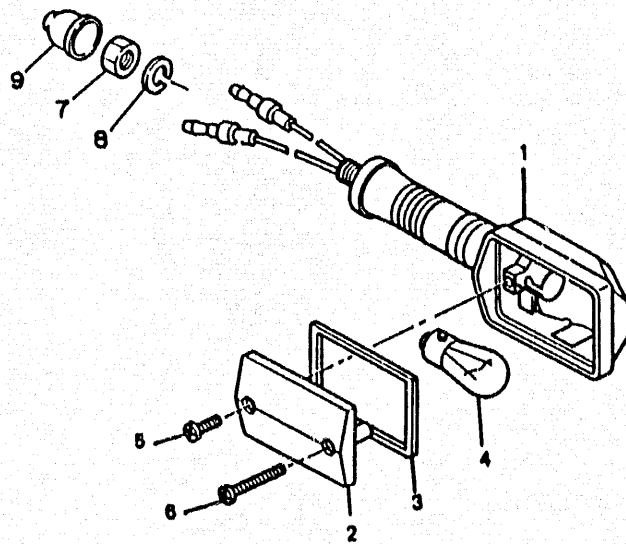


FIG.32 BLINKLEUCHTE

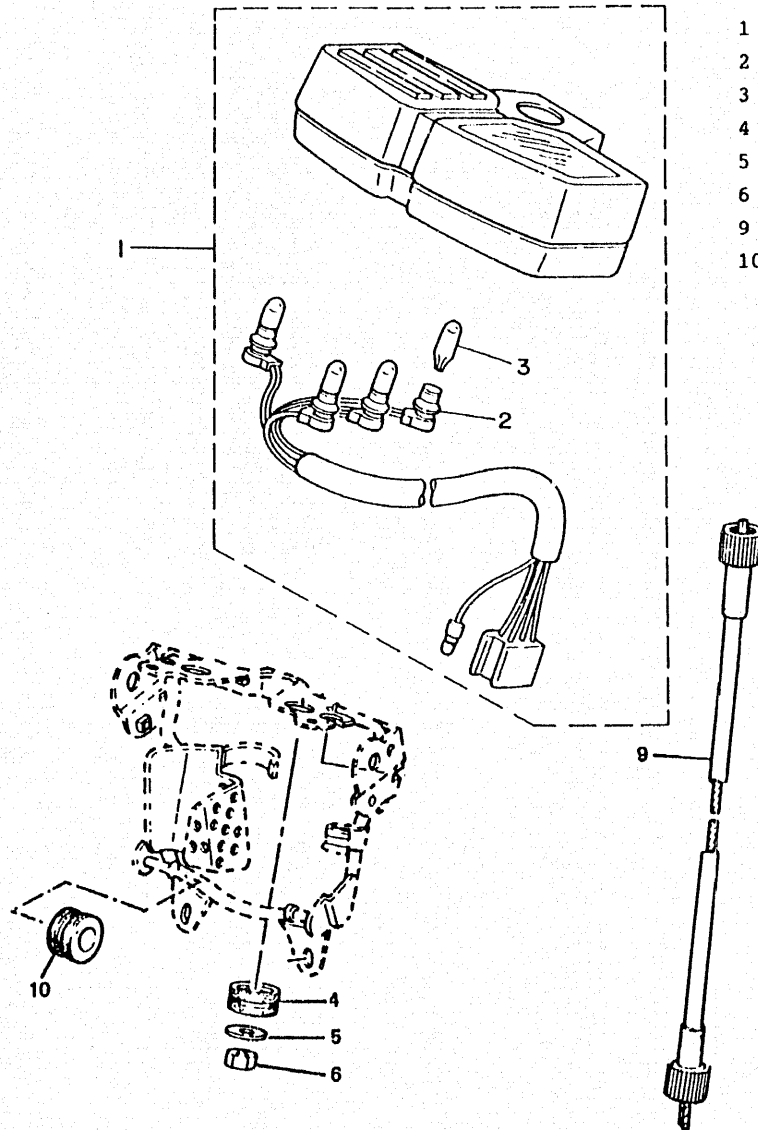
REF	TEILE.NR	BEZEICHNUNG	STCK	BEMERKUNG
1	3HL-H3310-00	VORDERER BLINKER KOMPL.	2	
2	5T8-H3312-10	SCHUTZGLAS, BLINKER	4	
3	5T8-H3313-10	DICHTUNG, SCHUTZGLAS	4	
4	3HL-H3331-00	GLUHLAMPE, BLINKER	4	
5	98580-04010	ZYLINDERKOPFSCHRAUBE	4	
6	97701-40530	BLECHSCHRAUBE	4	
7	95303-12600	MUTTER	4	
8	92901-12100	SCHEIBE	4	
9	10V-83365-00	KAPPE	4	
10	3HL-H3330-00	HINTERER BLINKER KOMPL.	2	



3HL1351-8280

E5

FIG. 33 METER



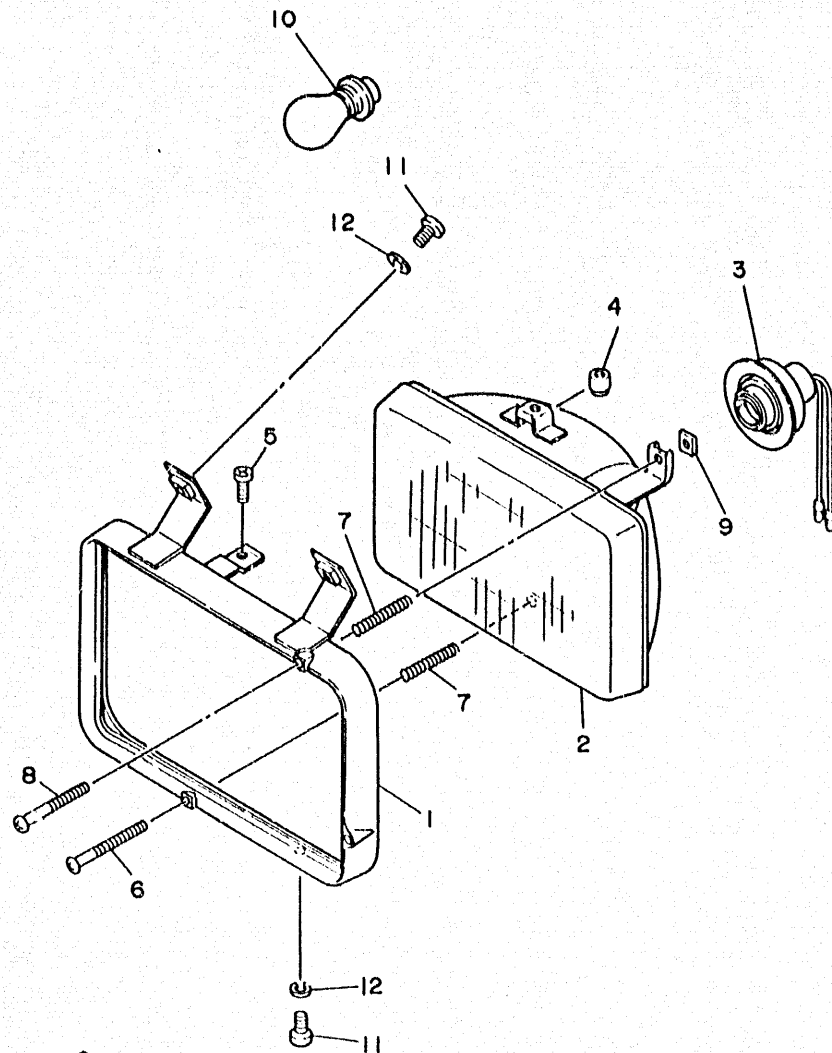
REF	TEILE.NR	BEZEICHNUNG	STCK	BEMERKUNG
1	3MP-83510-00	GESCHWINDIGKEITSMESSER	1	
2	3MP-83520-00	STECKERKABEL	1	
3	4G1-84744-00	GLUHBIRNE	4	
4	5T8-H3513-00	DAMPFER	2	
5	5T8-H3524-00	SPEZIALSCHEIBE	2	
6	95303-06600	MUTTER	2	
9	3HL-H3550-10	GESCHWINDIGK. KABEL KOMP	1	
10	90480-12053	GUMMITULLE	2	



3MR1321-9320

F5

FIG.34 SCHEINWERFER



REF	TEILE.NR	BEZEICHNUNG	STCK	BEMERKUNG
1	1NN-84315-00	RINGKRAENZ, SCHEINWERFER	1	
2	3MP-84320-00	SCHUTZGLAS KOMPL.	1	
3	1NN-84140-40	STECKERKABEL	1	
4	25G-84326-H0	MUTTER	1	
5	98501-05010	ZYLINDERKOPFSCHRAUBE	1	
6	1NN-84131-10	EINSTELLSCHRAUBE, RING	1	
7	1NN-84332-00	FEDER, SCHRAUBE	2	
8	1NN-84131-10	EINSTELLSCHRAUBE, RING	1	
9	1L9-84334-60	EINSTELMUTTER	2	
10	3MP-84314-00	GLUHBIRNE, SCHEINWERFER	1	
11	92506-06016	ZYLINDERKOPFSCHRAUBE	3	
12	90201-062A8	UNTERLEGSCHIBE	3	



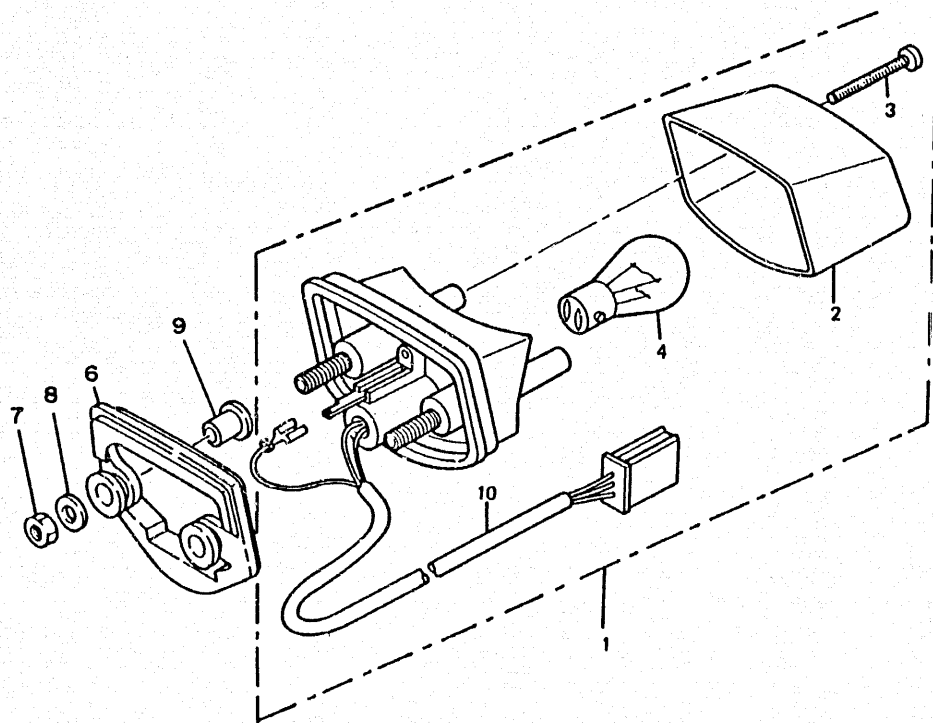


FIG. 35 SCHLUSSLEUCHTE

REF	TEILE.NR	BEZEICHNUNG	STCK	BEMERKUNG
1	3HL-H4710-00	SCHLUSSLICHT KOMPL.	1	
2	3HL-H4520-00	SCHLUSSLICHTFASSUNG KOMP	1	
3	3HL-H4524-00	BEFEST. SCHRAUBE, SCHUTZ	2	
4	3HL-H4535-00	GLUHBIRNE	1	
6	5T8-H4736-00	DAMPFER, SCHLUSSLICHT 1	1	
7	95303-06600	MUTTER	2	
8	90201-06812	UNTERLEGSCHIBE	2	
9	90387-07391	HULSE	2	
10	3HL-H4517-00	KABEL, SCHLUSSLICHT	1	



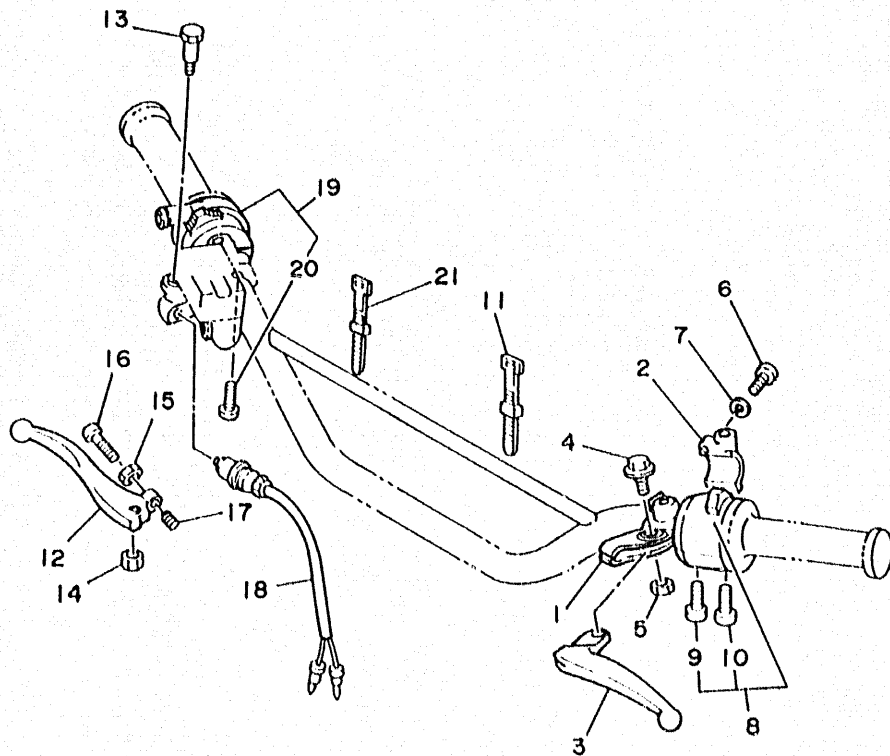
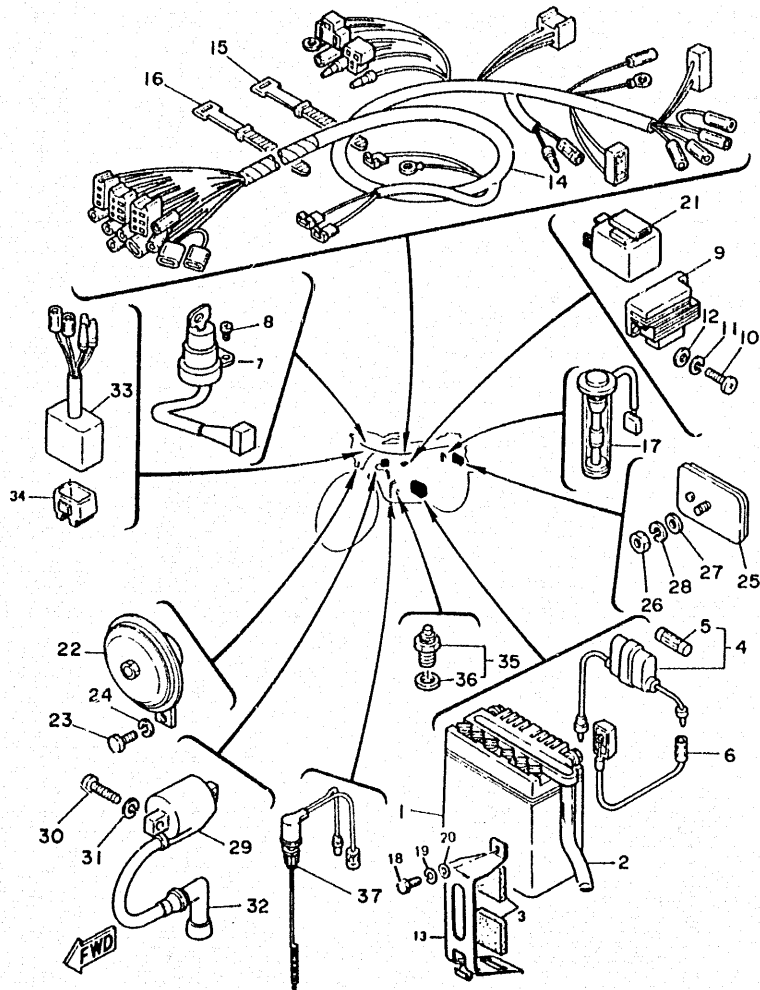


FIG. 36 LENKERSCHALTER HEBEL

REF	TEILE.NR	BEZEICHNUNG	STCK	BEMERKUNG
1	1LN-82911-00	HALTER, HEBEL 1	1	
2	33G-82913-00	HEBELHALTER 1, UNTEN	1	
3	5Y1-83912-00	HEBEL 1	1	
4	90109-06799	SCHRAUBE	1	
5	95616-06100	STEBBOLZEN	1	
6	98506-05020	ZYLINDERKOPFSCHRAUBE	2	
7	92906-05100	SCHEIBE	2	
8	3HL-83973-00	LENKERSCHALTER 3	1	
9	98506-05030	ZYLINDERKOPFSCHRAUBE	1	
10	98506-05022	ZYLINDERKOPFSCHRAUBE	1	
11	5T8-H3936-00	BAND, SCHALTERKABEL	2	
12	43F-83922-00	HEBEL 2	1	
13	90109-062Ae	SCHRAUBE	1	
14	95616-06100	STEBBOLZEN	1	
15	90170-06010	MUTTER	1	
16	90149-06289	SCHRAUBE	1	
17	90501-10312	DRUCKFEDER	1	
18	1A0-83980-3C	VORDERRAD-BREMSLICHTSCHA	1	
19	1R6-83976-01	LENKERSCHALTER 2	1	
20	90157-05027	ZYLINDERSCHRAUBE	2	
21	5T8-H3936-00	BAND, SCHALTERKABEL	2	



FIG. 37 ELEKTR. AUSRÜSTUNG

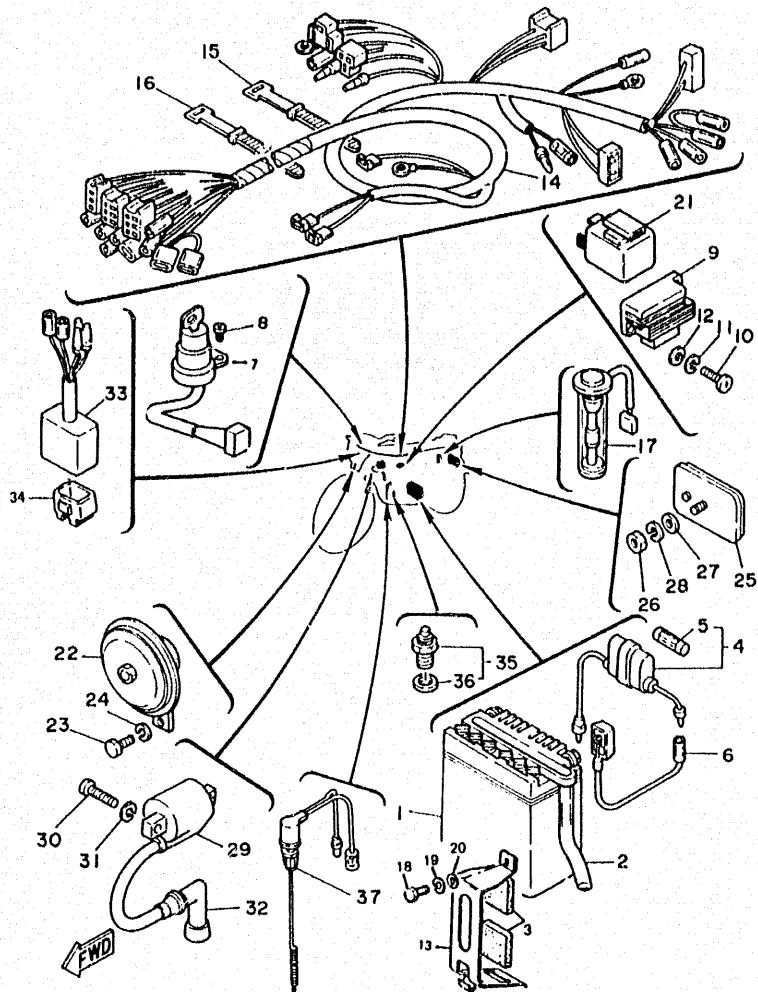


3MNI332-9370

REF	TEILE.NR	BEZEICHNUNG	STCK	BEMERKUNG
1	3HL-82110-00	BATTERIE KOMPL.	1	
2	90445-08171	SCHLAUCH	1	
3	3HL-H2121-00	KISSEN, BATTERIE	2	
4	5T8-H2150-00	SICHERUNGSHALTER KOMPL.	1	
5	116-82151-00	SICHERUNG	2	
6	10W-82115-00	POSITIVES KABEL	1	
7	3HL-H2510-10	HAUPTSCHALTER	1	
8	98901-04010	BLINDSCHRAUBE	2	
9	22J-81960-92	GLEICHRICHTER & SPANNUNG	1	
10	98501-05016	ZYLINDERKOPFSCHRAUBE	2	
11	92901-05100	SCHEIBE	2	
12	92901-05600	SCHEIBE	2	
13	3HL-H2128-00	KONSOLE, BATTERIE	1	
14	3MN-82590-00	KABELBAUM KOMPL.	1	
15	5T8-H3936-00	BAND, SCHALTERKABEL	3	
16	5T8-H3936-10	BAND, SCHALTERKABEL	2	
17	3HL-85720-00	OLSTANDANZEIGER	1	
18	97001-06012	SCHRAUBE	1	
19	92990-06100	SCHEIBE	1	
20	92990-06600	SCHEIBE	1	
21	53V-83350-40	BLINKERRELAIS KOMPL.	1	
22	35R-83371-20	SIGNALHORN	1	
23	97001-06012	SCHRAUBE	1	
24	92990-06100	SCHEIBE	1	
25	3G1-85130-01	HINTERER REFLEKTOR KOMPL.	1	
26	95303-05600	MUTTER	1	
27	92990-05200	SCHEIBE	1	
28	92901-05100	SCHEIBE	1	

FIG. 37 ELEKTR. AUSRUSTUNG

REF	TEILE.NR	BEZEICHNUNG	STCK	BEMERKUNG
29	2JN-82310-M0	ZUNDSPULE KOMPL.	1	
30	92501-06020	ZYLINDERKOPFSCHRAUBE	2	
31	92990-06100	SCHEIBE	2	
32	1J7-82370-00	KERZENSTECKER KOMPL.	1	
33	3MP-85540-C0	CDI-EINHEIT	1	
34	3MP-H5546-00	BAND	1	
35	2H7-82540-00	LEERLAUFSCHALTER KOMPL.	1	
36	341-82543-00	DICHTUNG	1	
37	1MK-H2530-V0	STOPPSCHALTER KOMPL.	1	



3MNI332-9370

K5

INHALTSVERZEICHNIS

MOTOR

ZYLINDER	B2
KURBELWELLE-KOLBEN	C2
OLPUMPE	D2
EINLASS	E2
VERGASER	F2-G2
AUSLASS	H2
KURBELGEHAUSE	I2
KURBELGEHAUSEDECKEL 1	J2
ANLASSER	K2
KUPPLUNG	L2-B3
GETRIEBE	C3
SCHALTNOCKE-GABEL	D3
SCHALTWELLE-PEDAL	E3

FAHRGESTELL

RAHMEN	F3
KOTFLUGEL	G3
SEITENDECKEL	H3
OLTANK	I3

HINTERRADSCHWINGE	J3
HINTERRADAUFHANGUNG	K3
LENKUNG	L3-B4
VORDERRADGABEL	C4
KRAFTSTOFFTANK	D4-E4
SITZ-TRAGER	F4
VORDERRAD	G4
VORDEBRAOBREMSE	H4
HINTERRAD	I4-J4
LENKER-KABEL	K4
HAUPTBREMSZYLINDER	L4
STANDER-FUSSRASTE	B5
MOTORVERKLEIDUNG 1	C5
LICHTMASCHINE	D5
BLINKLEUCHE	E5
METER	F5
SCHEINWERFER	G5
SCHLUSSLEUCHE	H5
LENKERSCHALTER-HEBEL	I5
ELEKTR-AUSRÜSTUNG	J5-K5

VERZEICHNIS

NUMMERNVERZEICHNIS	L16-M16
--------------------------	---------

NUMMERNVERZEICHNIS

90101-06278	I4	90209-18112	C2	90560-12208	G4	92906-06600	G3	94225-21812	G4	98511-04012	D5	3HL-11111-00	B2
90105-10308	H4	90240-10069	K3	90560-17123	L2	92906-06600	L3	94311-18838	I4	98511-04025	D5	5G1-11161-00	B2
90109-062A8	I5	90240-10072	K3	91401-16012	B5	92906-06600	L3	94330-21814	G4	98580-04010	D5	427-11161-00	B2
90109-06614	E2	90249-12008	B5	91401-20015	J4	92906-08100	F4	94332-18833	I4	98580-04010	E5	1T9-11161-00	B2
90109-06757	H4	90267-40076	G3	91401-20015	B5	92906-08500	H2	94416-21471	G4	98580-04016	G2	13N-11181-01	B2
90109-06799	I5	90267-48014	G3	91401-20015	B5	92906-08600	L3	94418-18171	I4	98701-05012	D3	3MN-11311-00	B2
90109-08183	I4	90280-03017	C2	91401-25020	D3	92906-08600	F4	94580-52122	I4	98701-05016	D5	353-11351-00	B2
90109-08368	J4	90282-05005	L2	91401-25020	K3	92990-03100	E2	94680-52001	I4	98901-04010	J5	4U5-11400-00	C2
90109-08829	B5	90334-12009	I2	91401-30025	G4	92990-05200	J5	94701-00110	B2	98901-04008	D2	2U2-11412-00	C2
90109-14485	D3	90338-09012	K4	91401-30025	J4	92990-06100	E2	95303-05600	D2	98906-06010	H2	2U2-11422-00	C2
90113-06013	L2	90338-16029	C3	91701-06032	B5	92990-06100	G3	95303-05600	J5	99001-08600	D2	12Y-11610-00	C2
90116-06026	B2	90340-12005	I2	91701-08038	B5	92990-06100	G3	95303-06600	J4	99001-10600	D3	12Y-11610-10	C2
90116-08804	I4	90386-18099	J3	92501-06012	C3	92990-06100	D4	95303-06600	F5	99001-10600	E3	12Y-11610-20	C2
90119-05001	L2	90387-064T3	G3	92501-06014	B3	92990-06100	J4	95303-06600	H5	99001-10600	E3	3T2-11631-01-97	C2
90119-06043	I3	90387-06500	K4	92501-06020	K5	92990-06100	J5	95303-06700	L2	99001-10600	E3	517-11633-00	C2
90119-06056	F3	90387-06825	D4	92501-06025	E2	92990-06100	J5	95303-06700	K4	99009-12400	K2	3T2-11635-01	C2
90123-08046	K4	90387-07391	C5	92501-06025	I2	92990-06100	K5	95303-08600	E3	99009-13400	C3	3T2-11636-01	C2
90149-06011	D4	90387-07391	H5	92501-06035	K4	92990-06600	J5	95303-08700	J4	99510-12016	I2	3R1-11651-01	C2
90149-06194	H4	90387-08884	B5	92501-06050	I2	92990-08100	H2	95303-08700	B5	99530-10014	J2	257-11681-00	C2
90149-06223	H3	90387-12283	G4	92501-06055	I2	92990-08100	L3	95303-12600	E5	99530-10014	J2	4U1-13101-01	D2
90149-06289	I5	90387-12819	J4	92506-06010	H2	92990-08100	J4	95303-06600	B2	99999-01529	C3	8Y0-13116-01	D2
90149-08094	E3	90387-12820	J4	92506-06012	E4	92990-10600	J3	95601-06100	I4			137-13137-00-10	D2
90157-05027	I5	90387-205E9	C2	92506-06014	G3	92990-10600	K3	95601-10100	J3			137-13138-01	D2
90159-06058	J3	90387-225N2	L4	92506-06016	E2	93102-04382	L2	95616-06100	I5			367-13146-01	D2
90159-06059	J3	90401-10034	L4	92506-06016	J2	93102-12106	E3	95616-06100	I5			248-13174-00	D2
90170-06010	I5	90430-04004	D2	92506-06016	G5	93102-17187	C3	95701-06500	F2			367-13174-00	D2
90170-08258	I4	90430-12038	I2	92506-06020	J2	93102-18008	G4	95701-08500	F3			2A3-13175-00	D2
90170-10038	K4	90445-05278	D2	92506-06035	J2	93102-20009	C2	95811-08090	F3			1E7-13176-00	D2
90170-12060	L2	90445-08171	J5	92506-06040	J2	93103-28011	C2	95811-08120	F3			353-13178-00	D2
90170-12175	D5	90445-09100	D4	92506-06040	J2	93103-28126	C2	97001-06012	G3			353-13552-01	D2
90171-12015	G4	90445-09353	I3	92506-06045	J2	93104-10085	B3	97001-06012	J5			278-13552-02	E2
90171-12015	J4	90445-117E0	H2	92516-06030	J2	93106-20002	I4	97001-06012	J5			3MN-13565-00	E2
90179-06176	B5	90460-33087	E2	92516-06030	J2	93109-15001	K2	97001-06020	G3			5G1-13610-00	E2
90179-08148	K4	90460-51059	E2	92701-06012	D3	93101-10090	D2	97001-06025	C5			2A3-13613-00	E2
90179-08842	I4	90465-05052	F3	92701-06018	F4	93210-21190	J2	97001-06030	D4			5G1-13616-00	E2
90179-12244	L2	90465-13154	D4	92901-04100	D5	93210-40407	H2	97006-08020	H2			353-13621-00	F2
90201-04325	G3	90467-08003	I3	92901-04100	D5	93210-99103	L2	97011-06010	C3			3MP-14412-00	E2
90201-047A2	G3	90467-08003	I3	92901-05100	D2	93306-20333	C3	97016-06016	L3			3HL-14420-00	E2
90201-06059	E4	90467-08003	D4	92901-05100	J5	93306-20465	C2	97016-06020	E3			3T2-14437-00	E2
90201-06067	G3	90467-10008	H2	92901-05100	J5	93306-301Y0	I4	97016-06020	F4			3T2-14451-00	E2
90201-062A8	H3	90468-02033	D2	92901-05600	J5	93306-301Y1	I4	97016-06025	K2			5T8-14452-00	E2
90201-062A8	E4	90468-02033	E2	92901-06200	B2	93306-301Y2	G4	97016-06025	L3			132-14613-00	H2
90201-062A8	G5	90468-26038	K2	92901-06600	E2	93306-30301	C3	97016-06025	L4			1NN-14752-00	H2
90201-06812	H5	90480-01401	H3	92901-06600	J4	93310-11268	C2	97026-06014	G3			353-15111-01	I2
90201-08624	D2	90480-12053	C5	92901-06600	K4	93310-418T0	C2	97026-08030	L3			353-15121-03	I2
90201-10118	L4	90480-12053	F5	92901-06600	K4	93430-10803	B5	97313-08016	E2			137-15353-00	D3
90201-105J4	D2	90480-14023	C5	92901-06600	B5	93440-12026	D3	97313-08016	E2			353-15362-00	J2
90201-12166	K2	90501-02217	D2	92901-08600	F3	93440-16089	C3	97313-08016	H2			492-15387-00	I2
90201-12535	D5	90501-08410	D4	92901-12100	D5	93440-16089	C3	97313-08016	L3			4U7-15416-00	J2
90201-12575	E3	90501-09292	D3	92901-12100	E5	93450-13022	C2	97506-06618	L4			4U7-15421-00	J2
90201-14813	B5	90501-10245	B5	92906-05100	I5	93501-04011	L3	97701-40530	E5			353-15437-02	J2
90201-20279	B5	90501-10312	I5	92906-06100	G3	93503-16010	L2	98501-03008	E2			353-15451-00	J2
90202-05005	H2	90501-20122	L2	92906-06100	G3	93503-16010	L3	98501-04006	D5			3T2-15481-01	I2
90202-06010	H2	90506-07066	L2	92906-06100	L3	93505-32002	D2	98501-05010	G5			353-15641-00	K2
90202-06010	D4	90506-18288	I4	92906-06100	L3	93603-22028	D2	98501-05016	D2			353-15651-00	K2
90208-12015	L2	90506-20041	B5	92906-06100	L4	93604-08071	D3	98501-05016	J5			2AL-15660-00	K2
90208-12015	L2	90508-26136	K2	92906-06100	C5	93604-10011	D3	98506-04012	L4			4U1-15664-00	K2
90209-13185	C3	90508-32054	E3	92906-06600	E2	93606-14081	D3	98506-05020	I5			248-15668-00	K2
90209-13817	C3	90508-32354	B5	92906-06600	H2	94170-218A1	G4	98506-05022	I5			353-16111-01	L2
		90560-12207	I4	92906-06600	G3	94190-188A2	I4	98506-05030	I5			5L3-16150-00	L2

NUMMERNVERZEICHNIS

22-16164-00	L2	34X-2580T-00	H4	5G3-85520-20	D5	3HL-F1611-40	G3	3HL-F3114-00	C4	5T8-F5188-00	J4	59X-W0041-00	L4
22-16164-00	L2	34X-25831-00	H4	3MP-85540-00	K5	3HL-F1611-10	G3	3HL-F3119-00	C4	5T8-F5311-10-12	I4	34X-W0046-01	H4
31-16321-00	L2	34X-25845-00	H4	3MR-85550-00	D5	3HL-F1611-50	G3	3HL-F3126-10	C4	5T8-F5315-00	G4	34X-W0047-00	H4
31-16324-00	L2	2KF-25850-00	L4	3MP-85560-00	D5	3MR-F1621-00	G3	3HL-F3129-00	C4	5T8-F5315-00	I4	51L-W0048-00	H4
41-16341-01	L2	2KF-25852-01	L4	3HL-85580-00	D5	3HL-F1623-00-11	G3	3HL-F3136-00	C4	5T8-F5321-03	I4	34X-W0057-00	H4
51-16342-00	L2	55U-25854-00	L4	3HL-85720-00	J5	3MR-F1624-00	G3	3HL-F3145-00	C4	5T8-F533A-00	I4	18A-W2534-00	I4
32-16346-00	L2	4L0-25862-00	L4	3HL-E4103-00	F2	3MN-F1685-00-11	G3	3HL-F3156-00	C4	3HL-F5371-00-11	I4		
57-16351-00	L2	56A-25867-00	L4	3MP-E4104-00	F2	3HL-F1711-50	H3	1NN-F3174-00-11	L3	5T8-F5381-00	J4		
37-16356-00	L2	3HL-25872-12	L4	3HL-E4106-00	F2	3HL-F1711-10-12	H3	3HL-F3191-40	C4	1MK-F5389-00	J4		
53-16357-00	L2	5R2-25917-00	H4	3HL-E4112-00	F2	3HL-F1711-60	H3	3HL-F3191-30	C4	5T8-F5412-01	I4		
57-16371-01	L2	34X-25919-00	H4	3MR-E4116-10	F2	3MN-F171L-00	E4	3HL-F3192-00	C4	3HL-F6111-00-13	K4		
53-16396-00	L2	34X-25926-00	H4	3HL-E4125-00	F2	3MN-F171M-00	E4	3HL-F3192-10	C4	5T8-F6241-00	K4		
53-17121-11	C3	34X-25937-00	H4	3HL-E4126-00	F2	3HL-F1721-50	H3	3HL-F3318-00	L3	5T8-F6242-00	K4		
53-17131-10	C3	3BN-26141-20	K4	3HL-E4126-00	F2	3HL-F1721-10-12	H3	3HL-F3318-20	L4	5T8-F6261-00	K4		
53-17141-72	C3	2KF-26141-00	K4	3HL-E4136-00	F2	3HL-F1721-60	H3	3HL-F3318-10	L4	3HL-F6311-10	K4		
53-17151-70	C3	3TB-26141-50	K4	3HL-E4137-00	F2	3HL-F1728-00	K4	3HL-F3319-30	L4	3HL-F6312-00	K4		
53-17211-01	C3	3BN-26142-20	K4	3MN-E4142-00	F2	3MN-F172A-30	E4	3HL-F3319-20	L4	3MP-F6321-00	K4		
57-17219-00	C3	2KF-26142-00	K4	3HL-E4156-00	F2	3MN-F172A-10	E4	3HL-F3340-10	C4	3MR-F6335-00	K4		
53-17221-00	C3	3BN-26142-30	K4	3HL-E4168-00	F2	3MN-F172A-40	E4	3HL-F3389-00	L4	5T8-F6363-00	K4		
53-17231-00	C3	434-26243-00	K4	3HL-E4169-00	F2	3HL-F172F-00	E4	5T8-F3416-00	L3	5T8-F6393-C1	K4		
53-17241-70	C3	1M1-26249-01	K4	3MN-E4181-10	G2	3MN-F172G-30	E4	3HL-F3435-10	L3	5T8-F7211-00	B5		
53-17251-70	C3	55V-26280-00	K4	3MN-E4198-00	G2	3MN-F172G-10	E4	3HL-F3441-10	L3	3MP-F7231-00	B5		
53-17411-10	C3	1E6-26342-00	K4	3MN-E4301-01	F2	3MN-F172G-40	F4	3HL-F3451-10	C4	1NN-F7311-00-11	B5		
0M-17421-00	C3	17W-28173-00	F3	3HL-E4312-00	F2	3HL-F172H-00	E4	3HL-F3452-10	B4	5T8-F7315-00	B5		
53-17471-00	C3	17W-28185-00	F3	3HL-E4331-00	F2	3HL-F172K-00	E4	3HL-F3453-10	L3	5T8-F7413-00	B5		
AL-18101-00	E3	2AL-81313-M0	D5	3MR-E4341-10	F2	3HL-F172L-00	E4	3HL-F3454-10	L3	5T8-F7421-00	B5		
53-18120-00	E3	22J-81960-92	J5	3MN-E4343-00	F2	5T8-F1745-01	L3	3HL-F3457-10	B4	5T8-F7431-00	B5		
53-18141-01	D3	3HL-82110-00	J5	3HL-E4349-00	G2	3HL-F174T-00	H3	3HL-F3469-00	B4	5T8-F7433-00	B5		
14-18178-00	E3	10W-82115-00	J5	3HL-E4371-00	F2	3HL-F1751-00	L3	5T8-F3482-00	L3	54Y-F8100-00	F3		
67-18197-00	E3	116-82151-00	J5	3HL-E4375-00	F2	5T8-F1771-00	L3	3MN-F4110-00-15	D4	1NN-F8351-00-16	C5		
53-18511-01	D3	2JN-82310-M0	K5	3HL-E4377-00	F2	3HL-F1778-00	H3	3MN-F4110-00-11	D4	1NN-F8351-00-12	C5		
53-18512-01	D3	1J7-82370-00	K5	3MN-E4383-00	G2	3HL-F179J-00	H3	3MN-F4110-00-14	D4	1NN-F8351-00-15	C5		
53-18513-01	D3	2H7-82540-00	K5	3HL-E4384-00	F2	3HL-F179J-10	H3	3HL-F4146-00	G2	3HL-F8368-A0	C5		
14-18531-00	D3	341-82543-00	K5	3HL-E4385-00	F2	3HL-F179J-20	H3	3HL-F414H-00	E4	3HL-F8368-80	C5		
05-18540-00	D3	3MN-82590-00	J5	3HL-E4386-00	F2	3HL-F179K-00	H3	3HL-F414J-00	E4	3HL-F8368-90	C5		
53-18547-00	D3	1LN-82911-00	I5	3HL-E4392-00	F2	3HL-F179K-10	H3	3HL-F4164-00	E4	3HL-H2121-00	J5		
14-18561-00	D3	33G-82913-00	I5	3MN-E441K-00	E2	3HL-F179K-20	H3	26H-F4181-00	D4	3HL-H2128-00	J5		
53-18562-00	D3	53V-83350-40	J5	3MN-E443E-00	G2	3HL-F179L-00	D4	5T8-F4182-01	D4	5T8-H2150-00	J5		
MR-21521-00	G3	10V-83365-00	E5	3HL-E4444-00	F2	3HL-F179L-10	D4	5T8-F4186-00	D4	3HL-H2510-10	J5		
3F-21773-00	H3	35R-83371-20	J5	3MP-E4453-00	E2	3HL-F179L-20	D4	3HL-F4341-00	G2	1MK-H2530-V0	K5		
3F-21773-00	H3	3MP-83510-00	F5	3MN-E4610-00-11	H2	3HL-F179M-00	D4	3HL-F4345-00	G2	3HL-H3310-00	E5		
01-22128-01	J3	3MP-83520-00	F5	3MP-E4615-00	H2	3HL-F179M-10	D4	3HL-F4345-00	G2	5T8-H3312-10	E5		
4X-22151-01	J3	5Y1-83912-00	I5	3MP-E4683-00	H2	3HL-F179M-20	D4	3HL-F4348-00	G2	5T8-H3313-10	E5		
J0-23317-00	C4	4JF-83922-00	I5	3MP-E4683-10	H2	3MP-F2110-01-11	J3	5T8-F4500-01	D4	3HL-H3330-00	E5		
56-23411-00	L3	3HL-83973-00	I5	3HL-E4718-00-11	H2	3MP-F2110-01-12	J3	3HL-F4501-00	G2	3HL-H3331-00	E5		
22-23411-00	L3	1R6-83976-01	I5	3MN-E4753-00-11	H2	3HL-F2126-00	J3	5T8-F4611-00	D4	5T8-H3513-00	F5		
56-23412-00	L3	1A0-83980-30	I5	5T8-E5411-01	J2	5T8-F2141-00	J3	5T8-F4612-00	D4	5T8-H3524-00	F5		
22-23412-00	L3	1NN-84131-10	G5	5T8-E5415-00	J2	3HL-F2153-00	J3	3HL-F4730-70	F4	3HL-H3550-10	F5		
4L-24186-00	D4	1NN-84131-10	G5	5T8-E5618-00	K2	3HL-F2210-00	K3	3HL-F4730-80	F4	5T8-H3936-00	I5		
HL-24311-00	D4	1NN-84140-00	G5	2UM-E5620-00	K2	3HL-F2241-00	J3	3HL-F4730-90	F4	5T8-H3936-00	I5		
09-24724-00	F4	3MP-84314-00	G5	1NN-E7461-00	C3	3HL-F2243-00	J3	3HL-F4731-70	F4	5T8-H3936-00	J5		
HL-25104-10	G4	1NN-84315-00	C5	5T8-E8111-00	E3	3HL-F2244-00	J3	3HL-F4731-80	F4	5T8-H3936-10	J5		
HL-25190-10	G4	3MP-84320-00	G5	5T8-E8113-00	E3	3HL-F2245-00	J3	3HL-F4731-90	F4	3HL-H4517-00	H5		
J0-25304-00	I4	25G-84326-H0	G5	3MP-F1110-00-13	F3	3HL-F2246-00	J3	3HL-F4739-00	F4	3HL-H4520-00	H5		
Y6-25351-00	I4	1NN-84332-00	G5	3MP-F1110-00-14	F3	3HL-F2251-00	J3	3HL-F4742-10	F4	3HL-H4524-00	H5		
RO-25355-00	I4	1L9-84334-60	G5	3MP-F1110-00-12	F3	3MP-F2311-00	J3	3MP-F4830-00-11	F4	3HL-H4535-00	H5		
7W-25448-10	I4	4GL-84744-00	F5	5T8-F1398-00	F4	3HL-F3102-20	C4	3HL-F5111-00-12	G4	3HL-H4710-00	H5		
HL-25715-40	H4	3G1-85130-01	J5	5T8-F1511-60	G3	3HL-F3103-00	C4	5T8-F5118-00	G4	5T8-H4736-00	H5		
HL-25715-50	H4	33G-85132-00	G3	5T8-F1511-30	G3	3HL-F3110-00	C4	5T8-F5181-00	G4	3MP-H5546-00	K5		
HL-25715-60	H4	5G3-85520-20	D5	5T8-F1511-70	G3	3HL-F3111-00	C4	5T8-F5188-00	G4	3HL-W0005-00	G2		